



NZ METAL ROOF AND WALL CLADDING

CODE OF PRACTICE

VERSION 23.09 / September 2023

The most recent updates to the NZ Metal Roof and Wall Cladding Code of Practice were published on 1 September 2023.

Versioning and presentation:

- Beginning with this revision the Code of Practice updates its version number with each update, to make it clear when the current update was published.

The version numbering uses a year.month pattern: for example this update is v23.09, where 23 indicates the year (2023) and 09 indicates the month (September).

Refer to [19 Revision History](#) for a log of specific changes in each update.

- An overall upgrade to styling for improved typeface readability and better contrast in headings.
- Additionally there are new "Quick Actions" on the COP Home page for reference to updates and interactive tools, and the registration process has been streamlined.

Substantial change to recommendations:

- [16 Maintenance](#) and all its sub-clauses have been comprehensively revised.
- [5.6.2 Sumps](#): Added recommendation to seal internal sumps against the sides and soles of the gutter.
- [14.19.3 Correctly Installed Gutters](#): Changed recommendation for gutter drainage to be more consistent with MBIE tolerances.
- In [3 Structure](#), tables and graphs have been rearranged to correspond to whether the design is under NZS3604 or AS/NZS1170:

[3.10 Fastening Pattern Tables – Designs to NZS 3604](#)

[3.11 Wind Load/Span Graphs – Designs to AS/NZS1170](#)

Editing and rearrangement:

- [8.5.4 Apron Flashings](#): Corrected name for chase and face fastened flashing to *Reglet flashings*. Added definition to the *Glossary*.
- [9.4.2.6 Sheetmetal Flashings on Trapezoidal Profiles](#): Clarified recommendations for trapezoidal sheet cover above the flashing when using under-soaker flashings.
- Revised the Introduction to [3 Structure](#) to make it easier for users to find the correct fastening pattern for NZS3604 or Wind Load/Span Graphs for SED (AS/NZS 1170) designs.
- [3.9 Fastener Requirements and Overhangs](#): renamed the clause.
- [4.9.4 Compatibility Table](#): Correction to use caution for contact between concrete and steel.
- Revised [8.2A Notched Flashing](#) illustration to recommend a screw fastener to the purlin in preference to a rivet.
- [7.3.2B Unfavourable Circumstances for Controlling Expansion](#): inserted vertical axis label: sheet length (m). Removed Pan Fixing as unfavourable condition for expansion control.
- [15.4.8 Standing Seam Roofing Wind Loads](#): Renamed table – Generic Standing Seam Clip Spacing.
- [12.2 Purlin Creasing](#): Copy editing for clarity.
- [8.2.1 Flashing Edges](#): Removed recommendation to provide longitudinal flashings with an anti-capillary gap, as this is impractical.

The rest of the updates consisted of minor corrections and edits.

For more detailed information, see [19.1 2023 – September](#).

NZ Metal Roof And Wall Cladding Code Of Practice v23.09

Table of Contents	2
1 Introduction	8
1.1 Disclaimer and Copyright	10
1.2 Scope	11
1.3 Standards and Related Documents	12
1.4 Acknowledgements	14
1.5 Disputes	15
2 Glossary	18
2.1 Definitions	19
2.2 Domestic Cladding Terminology	47
2.3 Industrial Cladding Terminology	48
2.4 Product Geometry	49
3 Structure	50
3.1 NZBC Clause B1 (Extract)	51
3.2 Standards	53
3.3 Performance	55
3.4 Profiles	56
3.5 Loads	62
3.6 Types of Load	65
3.7 Modes of Failure	72
3.8 Fasteners	78
3.9 Fastener Requirements and Overhangs	81
3.10 Fastening Pattern Tables – Designs to NZS 3604	85
3.11 Wind Load/Span Graphs – Designs to AS/NZS1170	89
4 Durability	100
4.1 NZBC Clause B2 (Extract)	101
4.2 Metal Corrosion	104
4.3 Metal Performance	105
4.4 Sacrificial and Barrier Protection	106
4.5 The Environment	107
4.6 Environmental Categories	109
4.7 Special Climates	116
4.8 Paint Durability	117
4.9 Compatibility	120
4.10 Other Causes of Corrosion	129
4.11 Inert Catchment	143
4.12 Ponding	145
4.13 Pitting Corrosion	146

NZ Metal Roof And Wall Cladding Code Of Practice v23.09

4.14 Swarf Staining and Cut Edge Corrosion	147
4.15 Clearances	150
4.16 Materials	154
4.17 Organic Coating	162
4.18 Accessories	166
5 Roof Drainage	168
5A Capacity Calculations	168
5.1 NZBC: Clause E1 – Surface Water	169
5.2 Roof Drainage Terminology	170
5.3 Roof Drainage Design	171
5.4 Gutters	178
5.5 Valleys	184
5.6 Rainwater Heads, Sumps, and Overflows	188
5.7 Outlets and Downpipes	192
5.8 Downpipe Spreaders	196
6 External Moisture Overview	198
6.1 NZBC Clause E2 External Moisture (Extract)	199
6.2 Compliance	200
6.3 Related Topics	201
7 External Moisture Roofing	202
7.1 Roof Pitch	203
7.2 Fastening Roofing	206
7.3 Thermal Expansion And Contraction	207
7.4 End Laps	210
8 External Moisture Flashings	211
8.1 Flashing Materials	212
8.2 Flashing Design	213
8.3 Metal Fascias and Facades	217
8.4 Flashing Cover	218
8.5 Flashing Types	224
8.6 Fastening Flashings	245
8.7 Sealants	249
8.8 Profile Closures	251
8.9 Compression Timber	254
8.10 Flashing Expansion Details	256
8.11 Metal Wall Cladding Flashings	259
9 External Moisture Penetrations	260
9.1 Penetrations Minimum Pitch	261
9.2 Additional Support	262

NZ Metal Roof And Wall Cladding Code Of Practice v23.09

9.3 Penetration Durability and Compatibility	263
9.4 Penetration Design	264
9.5 Boot Flashings	279
10 Internal Moisture	285
10.1 NZBC Clause E3: Internal Moisture (Extract)	286
10.2 Why Manage Internal Moisture	288
10.3 Special Requirements	289
10.4 Condensation	290
10.5 Building Airtightness	291
10.6 Insulation	293
10.7 Climate	294
10.8 Moisture Sources	295
10.9 Minimising Ingress of Water Vapour into the Ceiling Cavity	298
10.10 Ventilation Pathways	299
10.11 Underlay	305
10.12 Additional Information	310
11 Natural Light	315
11.1 Clause G7 NZBC	316
11.2 Natural Light Materials	317
11.3 Performance – Structure	320
11.4 Thermal Resistance	322
11.5 Light Transmission	324
11.6 Installing Translucent Sheets	325
11.7 Stand-Alone Rooflights	327
11.8 Flatsheet Rooflights	328
12 Fitness For Purpose	329
12.1 Roof Noise	330
12.2 Purlin Creasing	334
12.3 Flashing Buckling	336
12.4 Oil Canning	337
12.5 Colour Differential	340
12.6 Transport, Handling And Storage of rooflights	341
12.7 Drinking Water	342
13 Safety	343
HSWA 2015: Objective	343
13.1 HSWA 2015: Objective	344
13.2 Responsibilities	345
13.3 Working on Roofs	347
13.4 Working At Height	349
14 Installation	351

NZ Metal Roof And Wall Cladding Code Of Practice v23.09

14.1 Pre- Installation	352
14.2 Product Selection	353
14.3 Accepting Delivery	355
14.4 Site Safety	357
14.5 Handling	358
14.6 Walking On Roofs	359
14.7 Strippable Films	361
14.8 Double Lapping	362
14.9 Setting Out	363
14.10 Marking and Cutting	364
14.11 Overhang	365
14.12 Sealing and Joining	366
14.13 Fasteners	367
14.14 Fastener Installation	371
14.15 Modes Of Fastener Failure	373
14.16 Stop-ends	374
14.17 Turndowns (Drip Forming or Drip Edging)	376
14.18 Soft edging and Flashing	377
14.19 Avoiding Problems	378
14.20 Fixing Aluminium Sheeting	383
14.21 Completion	385
14.22 Tools Of The Trade	386
15 Other Products	389
15.1 Curved Roofs	390
15.2 Mounting Air Conditioning, Aerials, and Solar Units	403
15.3 Pressed Metal Tiles	404
15.4 Tray Roofing	416
15.5 Warm Roofs	430
16 Maintenance	443
16.1 Maintenance Compliance	444
16.2 Inspection	445
16.3 Reactive Maintenance	446
16.4 Scheduled Maintenance	447
16.5 Preventative Maintenance	448
16.6 Special Maintenance	449
16.7 Washing	450
16.8 Overpainting	452
17 Testing and MRM Standards	455
17.1 Metal Cladding Testing	456
17.2 MRM Fastener Performance Requirements and Testing	464
17.3 MRM Soft Edge Standard	469
17.4 MRM Pre-Painted Coil Standard – Performance Requirements	470

NZ Metal Roof And Wall Cladding Code Of Practice v23.09

18 Useful Information	472
18.1 Conversion Factors	473
18.2 Pitch & Rise Calculator	475
18.3 Material Density, Melting Point, Expansion And Modulus	478
18.4 Decadic Number System	481
18.5 Geometry And Measurement	483
18.6 Velocities	486
18.7 Cricket Penetration Patterns	488
18.8 Sheet Metal Work For Roofing Contractors.	492
19 Revision History	496
19A Revision Categories	497
19.1 2023 – September	498
19.2 2023 – June	503
19.3 2023 – March	510
19.4 2022 – November	512
19.5 2022 – June	515
19.6 2022 – April	520
19.7 2021 – December	522
19.8 2021 – September	524
19.9 2021 – June	526
19.10 2021 – March	531
19.11 2020 – December	534
19.12 2020 – September	536
19.13 2020 – June	538
19.14 2020 – March	541
19.15 2019 – December	542
19.16 2019 – August	546
19.17 2019 – May	553
19.18 2019 – February	562
19.19 2018 – November	564
19.20 2018 – October	572

NZ Metal Roof And Wall Cladding Code Of Practice v23.09

1

Introduction

The NZ Metal Roof and Wall Cladding Code of Practice (COP) is published by NZ Metal Roofing Manufacturers Inc. (MRM), to provide:

- acceptable trade practice for the fixing of metal roof and wall cladding and accessories.
- prescriptive detailing for designers and sets a benchmark for the standard of detailing and workmanship required over and above that required to comply with the NZBC.

The COP does not describe or dismiss alternative methods, which may need specific acceptance by the Building Consent Authorities.

It is published in accordance with current technology, materials, and building codes. The COP will be periodically updated to reflect changes in legislation and standards or improvements in technology and available materials.

The most current Code of Practice is available on the MRM website, www.metalroofing.org.nz/cop, as *Code of Practice Online* (MRM COP Version 23.09).

The following revisions to the NZ Metal Roof and Wall Cladding Code of Practice were published on 1 September 2023.

Versioning and presentation:

- Beginning with this revision the Code of Practice updates its version number with each update, to make it clear when the current update was published.
The version numbering uses a year.month pattern: for example this update is v23.09, where 23 indicates the year (2023) and 09 indicates the month (September).
Refer to [19 Revision History](#) for a log of specific changes in each update.
- An overall upgrade to styling for improved typeface readability and better contrast in headings.
- Additionally there are new "Quick Actions" on the COP Home page for reference to updates and interactive tools, and the registration process has been streamlined.

Substantial change to recommendations:

- [16 Maintenance](#) and all its sub-clauses have been comprehensively revised.
- [5.6.2 Sumps](#): Added recommendation to seal internal sumps against the sides and soles of the gutter.
- [14.19.3 Correctly Installed Gutters](#): Changed recommendation for gutter drainage to be more consistent with MBIE tolerances.

- In **3 Structure**, tables and graphs have been rearranged to correspond to whether the design is under NZS3604 or AS/NZS1170:

3.10 Fastening Pattern Tables – Designs to NZS 3604

3.11 Wind Load/Span Graphs – Designs to AS/NZS1170

The rest of the updates consisted of minor corrections and edits.

For more detailed information, see **19.1 2023 – September**.

1.1 Disclaimer and Copyright

Although the information contained in this Code has been obtained from sources believed to be reliable, New Zealand Metal Roofing Manufacturers Inc. makes no warranties or representations of any kind (express or implied) regarding the accuracy, adequacy, currency or completeness of the information, or that it is suitable for the intended use.

Compliance with this Code does not guarantee immunity from breach of any statutory requirements, the New Zealand Building Code or relevant Standards. The final responsibility for the correct design and specification rests with the designer and for its satisfactory execution with the contractor.

While most data have been compiled from case histories, trade experience and testing, small changes in the environment can produce marked differences in performance. The decision to use a particular material, and in what manner, is made at your own risk. The use of a particular material and method may, therefore, need to be modified to its intended end use and environment.

New Zealand Metal Roofing Manufacturers Inc., its directors, officers or employees shall not be responsible for any direct, indirect or special loss or damage arising from, as a consequence of, use of or reliance upon any information contained in this Code.

New Zealand Metal Roofing Manufacturers Inc. expressly disclaims any liability which is based on or arises out of the information or any errors, omissions or misstatements.

If reprinted, reproduced or used in any form, the New Zealand Metal Roofing Manufacturers Inc. (NZMRM) should be acknowledged as the source of information.

Before using this Code, please refer to the New Zealand Metal Roofing Manufacturers Inc. website (www.metalroofing.org.nz) for the most recent updates on information contained in this Code.

1.1.1 Code of Practice Update-Policy

For continued improvement and to keep up with new developments, New Zealand Metal Roofing Manufacturers Inc. (NZMRM) publishes quarterly updates to this Code of Practice

From September 2023, the nominal Version number of the Code of Practice follows a "year.month" pattern, beginning with v23.09, for clear identification of the date of the latest updated version.

Please note:

- Always use the current online Code of Practice to ensure you have the most recent recommendations.
- Having registered to access the Code of Practice, you will be notified by email of the most notable changes at the publication of each update.
- A comprehensive history of revisions with a detailed log of changes is available at [19 Revision History](#).
- Archival copies of previous versions are available if required.

Please contact admin@metalroofing.org.nz with details if you have a specific requirement.

1.2 Scope

This Code of Practice provides requirements, information and guidelines, to the Building Consent Authorities, the Building Certifier, Specifier, Designer, Licensed Building Practitioner, Trade Trainee, Installer and the end user on the design, installation, performance, and transportation of all metal roof and wall cladding used in New Zealand.

The calculations and the details contained in this Code of Practice provide a means of complying with the performance provisions of the NZBC and the requirements of the Health and Safety at Work Act 2015.

The scope of this document includes all buildings covered by NZS 3604, AS/NZS 1170 and those designed and built under specific engineering design.

It has been written and compiled from proven performance and cites a standard of acceptable practice agreed between manufacturers and roofing contractors.

The drawings and requirements contained in this Code illustrate acceptable trade practice, but recommended or better trade practice is also quoted as being a preferred alternative.

Because the environment and wind categories vary throughout New Zealand, acceptable trade practice must be altered accordingly; in severe environments and high wind design load categories, the requirements of the NZBC will only be met by using specific detailing as described in this Code.

The purpose of this Code of Practice is to present both Acceptable Trade Practice and Recommended Trade Practice, in a user-friendly format to ensure that the roof and wall cladding, flashings, drainage accessories, and fastenings will:

- comply with the requirements of B1, B2, E1 E2 and E3 of the NZBC;
- comply with the design loading requirements of AS/NZS 1170 and NZS 3604 and with AS/NZS 1562;
- have an optimised lifespan; and
- be weathertight.

1.3 Standards and Related Documents

1.3A

Standard	Year	Title
NZ 2295	2017	Pliable, permeable building underlays. (either NZS 2295 2017 or NZS 2295 Amendment 1 2017)
NZS 3602	2003	Timber and wood based products for use in building.
NZS 3603	1993	Amendment 4 2005 Timber Structures Standard.
NZS 3604	2011	Timber Framed Buildings.
AS/NZS 1170.0	2002	Amendment 5 2011 Structural design actions. General Principles. Commentary to Parts 0, 1 and 2.
AS/NZS 1170.1	2002	Amendment 2 2009 Structural design actions. Permanent, imposed and other actions.
AS/NZS 1170.2	2011	Amendment 4 2016. Structural design actions. Wind Actions.
AS/NZS 1170.3	2013	Amendment 1 2007 Structural design actions. Snow and ice actions
AS 1562.1	1992	Design and Installation of sheet roof and wall cladding – Part 1 Metal
AS 1562.3	2006	Design and Installation of sheet roof and wall cladding – Part 3 Plastic (was AS/NZS 1562.3 1996)
AS/NZS 1734	1997	Aluminium and aluminium alloys - Flat sheet, coiled sheet and plate
AS/NZS 2728	2013	Prefinished/prepainted sheet metal products for interior/exterior building applications—Performance requirements
AS/NZS 4257	1994/97	Plastic roof and wall cladding materials. Parts 0-9 Methods of Test.
AS/NZS 4389	2015	Roof Safety Mesh.
AS/NZS 4600	2005	Amendment 1 2010. Cold-formed Steel Structures.
AS 1391	2007	(R2017) Metallic materials - Tensile testing at ambient temperature
AS 1397	2012	Continuous hot-dip metallic coated steel sheet and strip - Coatings of zinc and zinc alloyed with aluminium and magnesium
AS 3566.1	2002	1. General requirements and mechanical properties
AS 3566.2	2002	2. Corrosion resistance requirements. (Withdrawn)
AS 4256	2006	Plastic roof and wall cladding materials. (Now AS only previously AS/NZS 4256 1994). Parts 1-5. Plastic materials.
BS 1470	1987	Specification for wrought aluminium and aluminium alloys for general engineering purposes. (Replaced by 9 EN Standards) See AS 1734
BS 2870	1980	Specification for rolled copper and copper alloys. (Replaced by EN standards)
BS EN 988	1987	and BS EN 1179 2003 Specification for zinc alloy sheet and strip

Standard	Year	Title
ISO 9223	2012	Corrosion of metals and alloys. Corrosivity of atmospheres - Classification.
ISO 9224	2012	Corrosion of metals and alloys. Corrosivity of atmospheres - Guiding values for the corrosion categories.
ISO 9225	2012	Corrosion of metals and alloys -- Corrosivity of atmospheres -- Measurement of environmental parameters affecting corrosivity of sites
ISO 9226	2012	Corrosion of metals and alloys -- Corrosivity of atmospheres -- Determination of corrosion rate of standard specimens
AS/NZS 3500.3	2015	Stormwater drainage
AS/NZS 2179.1	2014	Metal shape or sheet rainwater goods, and metal accessories and fasteners
AS 2180	1986	Metal rainwater goods - Selection and installation
HB 114	1998	Guidelines for design of eaves and box gutters
AS 4312	2008	Atmospheric corrosivity zones in Australia
HB 39	2015	Installation code for metal roofing and wall cladding
AS/NZS 2312	2002	Guide to the protection of structural steel against atmospheric corrosion by the use of protective coatings
AS 4040.0	1998	Methods of testing sheet roof and wall cladding Introduction, list of methods and general requirements
AS 4040.1	1998	Methods of testing sheet roof and wall cladding Resistance to concentrated loads
AS 4040.2	1998	Methods of testing sheet roof and wall cladding Resistance to wind pressures for non-cyclone regions
AS/NZS 4200.1	2017	Pliable building membranes Part 1: Materials
AS 4200.2	2017	Pliable building membranes Part 2: Installation

1.4 Acknowledgements

The MRM Technical Committee continuously update this COP, which was originally authored by Stuart Thomson.
Our thanks to advisors, designers and trades people for their input.

1.5 Disputes

Under the provisions of the Building Act and the NZBC, a contractor who undertakes to do work on a building implies that he can produce an effective and sound result which will fulfil its intended purpose.

There is a customer expectation, backed by consumer legislation, that the finished work will leave the building weathertight, and the work done will comply with the NZBC and will be to a standard that is described as "acceptable trade practice".

"Acceptable trade practice" and "good trade practice" for the Roofing Industry are both described and contained in this Code of Practice. In addition to any contractual or verbal offer there may also be a written obligation given in the form of a warranty. See [16.9 Material Selection](#)

All contractors should ensure that materials they use comply with the requirements and specifications contained within this Code of Practice. All suppliers' or manufacturers' product literature should be dated; and where superseding previous literature the dates should be referenced. The user must ensure that suppliers or manufacturers product literature is the latest version published.

Contractors must be satisfied that the product as described in the product literature is acceptable to the Territorial Authority, and contractors must be aware of their liability under law and the contractual documents they have signed or agreed to.

Customer expectation is supported by law that states that the material and product used must be fit for its intended purpose, and the liability of each of the parties is assessed on their "failure to warn that the product would not fulfil a perceived function".

Poor workmanship is a common cause of dispute and it is often given as the reason for non-payment between the sub-contractor and contractor or owner. This Code of Practice provides a standard of workmanship and a benchmark for arbitration.

It is in the interest of all parties to avoid the cost and delay of litigation and although there are other voluntary ways to settle disputes, they all require some compromise by those concerned.

One voluntary method is negotiation by calling a site meeting where all interested parties can air their grievances across a table and draw up a programme of rectification and reach an agreement over responsibilities and payment.

Any agreement must be recorded, signed and state what is to be done, how much is to be paid, by whom, by when, and how it will be accepted and checked. If no agreement can be reached then a solution may be found through mediation.

The Weathertight Homes Resolution Services Act 2006 provides for a mediation service to be available to dwelling/house owners with eligible claims. The claiming owner and any of the other parties against whom the claim is made may agree to refer the claim to mediation, with provision for binding settlements by agreement. This service is restricted to leaky homes built within 10 years of the claim.

1.5.1 Mediation

Mediation is a cost-effective, confidential, and voluntary process where the mediator is the facilitator who assists the parties to come to a negotiated agreement. Mediation concentrates on the parties' interests rather

than on their rights, when often both parties realise that they are partly at fault and wish to resolve the dispute and accept a compromise, as opposed to litigation. Any recorded settlement in a mediation agreement can be enforced as a contract, but if they cannot reach a settlement, they can refer to arbitration or the courts.

A mediator acceptable to all parties is appointed and should act independently, avoid unnecessary expense and comply with the principles of natural justice. The mediator's task is to help the parties identify the issues and options for settlement and look for a settlement that is equitable to all concerned. All relevant documents including specifications, plans, quotations, and written submissions setting out the basis of the complaint and the rebuttal by the other party must be made available to the mediator.

After an investigation, site visits, and discussion with all the parties, the mediator, using trade benchmarks such as this Code of Practice and drawing on experience can apportion responsibilities and instruct rectification work be done. This method can provide a quick and inexpensive outcome with costs shared by both parties, but the decision is not binding and must be mutually agreed to.

Informal resolution of disputes does not necessarily uncover the facts; and as material or installation failures are not necessarily publicly disclosed, improvement can be inhibited.

Mediation does provide the opportunity to 'move on' and does not always jeopardize business relationships as litigation invariably does.

1.5.2 Adjudication

The Construction Contracts Act provides for a process of dispute resolution called adjudication, to be the first option if negotiation fails. It provides a thirty-day formal process whereby the adjudicator is appointed by the claimant, and the respondent cannot opt out. The process is designed mainly for payment disputes, but it can also be used for workmanship disputes and is expected to become the normal dispute resolution method in the Construction Industry.

The adjudicator's decision, called a determination, is binding and enforceable by the courts. An unsatisfied party can only appeal an adjudication after complying with the determination. The adjudication is subject to confidentiality, except by mutual consent or if the information is already in the public domain.

The disadvantage of both mediation and adjudication is that the faults are not made known to the roofing industry, who should be able to learn from the mistakes of the past.

Where the amount in question is under \$7,500, or \$12,000 by agreement with the other party, an alternative method is to file the complaint with the Disputes Tribunal. The parties usually represent themselves, without lawyers, and a compromise outcome is sought by a referee. This method of settlement gives no assurance of an equitable outcome or that the outcome will be based on technical grounds; the main purpose of this court is to seek agreement between the parties.

1.5.3 Arbitration and Litigation

Arbitration is usually a strict and formal process similar to litigation in which the parties may be legally represented and select and pay for the arbitrator. Arbitrators must comply with the Arbitration Act; their imposed decision is known as an award, and it is final and binding.

The final and expensive alternative is litigation. That usually involves suing for breach of contract, non-payment, non-performance, faulty materials, or non-compliance. Judgment is publicly imposed and usually made by comparison with “state of the art” materials and practice available at the time the contract was signed.

Both arbitration and litigation can be prolonged and the parties’ cost may exceed the amount in dispute.

When roofing contractors sublet the contract, they assume the same responsibility as though they carried out the work.

To avoid disputes, roofing suppliers and contractors must give adequate instruction, training, and supervision. They should also keep their staff informed of industry developments and with the contents of the New Zealand Metal Roof and Wall Cladding Code of Practice.

2

Glossary

The glossary section provides definitions and descriptions of commonly used terms, as well as illustrations of domestic cladding terminology, industrial cladding terminology, and profile geometry.

2.1 Definitions

The glossary provides a list of definitions for commonly used terms in the roof and wall cladding industry.

2.1A Definitions

Absorption	The ability of a material to accept liquid within its body.	
Acceptable solution	A prescriptive means of compliance with the performance requirements of the NZBC, approved by the Ministry of Business, Innovation and Employment.	
Acceptable trade practice	The minimum standard of design and workmanship to comply with the performance requirements of the NZBC.	
Accessories	Gutters, ridge capping, ventilators, flashings, downpipes, brackets and their fixings.	
Action-effect	A force due to a load.	
Acute angle	An angle that is less than 90°	
Alloy	A metallic substance composed of two or more chemical elements, at least one of which is a metal, combined to give enhanced strength, resistance to corrosion or lower the melting point.	
Aluminium/zinc	A continuously hot-dipped coating used to protect steel against corrosion, commonly consisting of 45% zinc and 55% aluminium by mass, generally conforming to AS/NZS 1397.	AZ; Zincalume®; Galvalume; Aluzinc; Duralume
Anneal	Softening a metal by heating, to restore or increase its ductility.	
Annular grooved nail	A nail having a shank deformed with a series of circular grooves.	
Anodic	Galvanic corrosion can occur when two metals are connected in moist or wet conditions. The anodic metal, being more active (-), sacrifices itself to protect the more noble metal in the galvanic series, cathodic (+).	
Applied finish	A surface finish applied to metal tiles, shakes, or accessories subsequent to pressing or forming.	Post-form painting
Approved	Any documentation, solution or method that is accepted by a recognised authority.	
Apron	A near-horizontal flashing with a vertical upstand that covers the intersection between a vertical and a horizontal or sloping surface. It can run across the roof profile (transverse) or in the same direction (longitudinal) and prevents water ingress or sheds water from a higher wall or roof onto a lower roof.	Abutment flashing

Astragal		A metal strap used to fasten downpipes to a wall.	Standoff bracket
Asymmetrical profile		A profile that has a different configuration on opposite sides of the horizontal centre axis. The opposite of symmetrical.	
Average Recurrence Interval	ARI	The rainfall intensity in New Zealand is determined by the rainfall during a ten minute period, measured in millimetres per hour. The ARI represents the expected timespan between exceedances of a given rainfall intensity.	
Awning		A roof projecting from a building, usually open on three sides.	Canopy
Baby Iron		A miniature corrugated profile rolled with 6 mm high ribs.	Sparrow iron; mini-corrugate; and mini-iron
Backer coat		An organic coating on the reverse side of a pre-painted strip or coil, not intended for external exposure.	
Back-out		The condition when a fastener works loose due to timber shrinkage, thermal movement, vibration or an incorrect thread type.	
Barge flashing		A flashing covering the intersection of a roof surface and a lower vertical surface or covering the intersection of a roof surface and a lower vertical surface.	Barge roll; cover roll; ridge roll; barge mould; square barge
Base metal thickness	B.M.T.	The thickness of the bare or base metal before any subsequent coating.	Gauge
Battens		A narrow timber, steel or polystyrene member attached to a roof or wall structure, used to attach metal cladding, metal tiles, shakes or shingles to the structure. It can also function as a spacer.	
Bay		A wide pan of fully supported roof cladding laid between standing seams or rolls.	
Bead		(a) A curled stiffening to a metal edge (b) A rounded strip of sealant. (c) A ball-shaped piece of solder or brazing.	
Bend radius		The formed outside radius on a flashing or sheeting.	
Blind Rivet		A small-headed hollow tubular fastener with an expandable body for joining sheet metal; capable of being fastened from one side.	Rivet.
Boot flashing		A proprietary EPDM prefabricated flashing used to weatherproof circular pipes protruding from a roof or wall.	

Bossing		The working of a malleable metal into a required shape, using wooden or plastic tools.	Dressing
Box gutter		(a) A square or rectangular internal gutter between two roof surfaces or at a parapet wall. (b) A square profile spouting attached to an external wall or fascia.	
Brazing		The joining of metals using an alloy with a lower melting temperature than either of the metals to be joined.	
Brittle roofing		Flat, troughed or corrugated plastic, asbestos, or other sheeting that is or can become brittle.	
Broken bond		Tiles laid so that the side laps of any two adjacent rows of tiles down a roof do not line up and are staggered or offset.	
Buckling		A loss of the original shape of metal, by compressive bending, bearing or shear loading.	kink; ding; wrinkle; bulge
Building Consent Authority	BCA	A Building Consent Authority accredited by the Ministry of Business, Innovation and Employment (MBIE) to issue building consents. BCAs are usually local and district councils, but they can also be regional councils (for dams) and private organisations.	
Building Insulation Blanket	BIB	Lightweight, flexible bulk insulation that is supplied in a continuous roll.	
		F.F.B.I.B. Building insulation blanket faced with foil.	
Building paper		An absorbent permeable membrane made from treated kraft paper, placed under roof or wall cladding.	permeable roofing underlay
Bullnose		A shaped piece of roof cladding, curved near to a quarter circle on its outer end, and used predominately as veranda roof sheeting.	
Butt strap		A soaker under flashing, used as an expansion joint.	
Butterfly roof		A structure having two inward sloping roofs, draining to an internal gutter.	
Camber		(a) The deviation from a straight line of a side edge of metal cladding, flashing or unformed coil. (b) A slight convex curve of a surface, such as in a roof deck. (c) A load-induced curve, or a pre-induced curve to counter the effect of a member bending under load.	
Canopy		A cantilevered roof without walls over a doorway.	awning
Canterbury prickle		A small shaped capping to a roof rib at a change of pitch.	rib cap

Capillary	The action that causes movement of moisture between two surfaces in close contact.	capillary action; capillary attraction; wicking.
Capillary groove	An indentation formed in the edge of a metal cladding profile or flashing to prevent capillary action.	capillary barrier; anti-capillary edge
Capping	The top flashing of a wall, parapet or balustrade.	coping
Cat ladder	A ladder fixed vertically to a wall or used on a steeply pitched roof as a temporary means of access.	roof ladder
Catchment	The roof or roof and wall area above a gutter, valley, or penetration that will collect rainwater.	
Cathedral roof	A roof having a pitch over 45°.	
Cathodic protection	The protection of one metal by another by the more active (Anodic) metal reacting with the elements in preference to the other	sacrificial protection
Cavity construction	A roof or wall construction that provides a drained air gap separation from the external cladding.	
Chalking	The result of weathering on an organic paint film, the degradation of which produces a chalky surface layer.	
Chase	A groove or recess cut into a concrete or block wall to accommodate a flashing.	
Chord	(a) The horizontal member (bottom chord) or a pitched member (top chord) of a truss. (b) A straight line drawn across a circle with each end touching the circumference.	
Cladding	Roof sheeting fixed to the roof structure, or wall sheeting fixed to walls as the weather-resistant surface of a building.	
Cleat	A continuous concealed clip without external fixings used to fasten roof cladding or flashings.	
Clerestory roof	A roof covering of a high vertical window between two opposing roof planes of different heights, used for borrowed light or ventilation.	
Clip	A small fixing used to secure roof cladding, flashings or pipes to the structure.	
Closure strip	A metal or plastic flashing, blocking open ribs or pans, to prevent the ingress of water, wind, and vermin.	bird-proofing; filler block; foam seal

Coating mass	The weight of the metallic protection given to steel by a zinc or aluminium/zinc coating, usually described in grams per square metre (g/m ²), e.g., Z 450, AZ 150. Sheet or coil is measured and described as including both sides. Articles which are hot-dipped after fabrication are measured and described as including one side only.	
Code of practice	COP	Prescriptive quantitative and qualitative criteria by which a product or system can comply with specified performance requirements.
Codemark	Codemark is a product certification scheme, supplied by an accredited certification body, showing that a product meets the requirements of the Building Code. Building Consent Authorities must accept a Codemark product-certificate as evidence of compliance with the NZBC.	
Coil-coating	The continuous application of a metallic or organic coating to a metal coil.	
Cold rolling	A metal thickness reduction manufacturing process, by applying pressure to metal coil at moderate temperatures.	
Cold Soldering	Using a sealant or adhesive to bond two pieces of metal together.	Soldering
Collar	A round over-flashing attached and sealed to a pipe to weatherproof a penetration.	
ColorCote®	Pre-painted steel and aluminium for use as roofing, wall cladding, or roofing accessories, manufactured by Pacific Coilcoaters.	
Colorsteel®	Pre-painted steel for use as roofing, wall cladding, or roofing accessories, manufactured by New Zealand Steel	
Composite roof	A factory insulated panel with metal cladding on both sides used to cover a roof or a wall.	sandwich panel; composite panel; panel roof; cool room panel
Concealed fastening	A method of fixing a roof by means of hidden, or secret fixing clips or brackets.	secret fix; clip fix
Condensation	The process by which a vapour such as water vapour changes phase to a liquid.	Sweating
Conduction	The transmission of heat through a material by contact between the particles of matter.	
Contractor	A person or company who enters a verbal or written agreement with another party to perform an agreed scope of work.	roof fixer

Convection	The transport of heat within a gas or fluid by the relative movement of those parts that differ in density.	
Corrosion	The process by which something erodes because of a chemical reaction.	rust
Corrugate	A profiled sheet formed into a series of sinusoidal or circular curves.	corrugated iron
Counter-batten	A spacer of timber or steel fixed to a purlin or batten, running transversely to the purlin.	
Cover	(a) The net width of sheeting less the lap. (b) The net width of a flashing that covers sheeting.	effective cover
Creep	(a) The metal deformation, or a change in shape that increases continuously when under constant load or stress. (b) The change in a sheet's laying module when subsequent sheets are laid out of line or out of square.	
Crest	The top surface of a rib or corrugation	crown; rib
Crevice corrosion	The rapid pitting corrosion that occurs in crevices, pockets, or fissures when a patina or oxide film is prevented from forming or reforming by the concentration or depletion of dissolved salts or oxygen in stagnant water.	
Cricket	A metal roof flashing designed and constructed to divert water around a penetration and to avoid ponding.	raised curb
Crimp curving	A method of forming a curve on profiled sheeting by discrete indentations; causing a concave curve in the rib or a convex curve in pan	
Crown	The top of a curved roof or rib.	
Cupola	A small roofed structure on a ridge to provide ventilation, or designed for aesthetic purposes.	
Curb	A gutter or apron flashing around a penetration.	kerb
Cyclonic winds	Strong winds rapidly spiralling clockwise into a centre of low pressure in the Southern hemisphere.	hurricane; typhoon
Deck	The substrate of a structure that supports claddings that require to be fully supported.	
Decking	A predominantly flat secret fixed roofing profile; includes trough and tray profiles.	tray; secret-fixed trough
Deflection	The deviation from a straight line induced by a load or action.	
Deformed shank nail	Nails with annular, spiral or otherwise deformed shanks.	enhanced shank nails
De-indexing	The releasing of interlocking profiled sheets.	
Depth	The vertical height of a rib or gutter.	

Design wind load		The site design wind pressure in kilopascals (kPa) on a specific part of a structure, modified by pressure coefficients.	
Design wind speed	V _{des}	The design wind load expressed as wind speed.	
Dewpoint		The temperature at which water vapour condenses, which varies with the relative humidity and the pressure.	
Ding		Permanent creasing of a rib or sheet, usually due to damage on a roof, resulting in structural depreciation.	
Diverter		(a) A penetration flashing design used to prevent the accumulation of dirt and debris, which diverts the water runoff by folding the back curb at an angle to the penetration. (b) An angle fastened to a flashing to channel water away from a penetration, obstruction or a wall.	
Dog-ear		A three-dimensional box-like internal corner formed in metal without cutting.	pig's lug; stop end
Dominant opening		An opening in the external surface of a closed building, greater than opposing openings, which directly influences the internal wind pressure.	
Dormer		A roofed window structure projecting at right angles from a sloping roof surface. It can be configured as a shed dormer, gable dormer, or eyebrow dormer.	
Downpipe		A pipe used to carry roof water from gutters and roof catchments to drains or storage tanks.	downspout
Downturn		That part of the trough of a sheet turned down into a gutter.	turndown
Drape curving		The use of metal cladding to cover a curved roof, using its own weight and not being pre-curved.	spring curving
Dressing		The operation of flattening or beating metal into the required shape.	bossing
Drip		(a) An outward projecting edge formed on a metal flashing to direct water away from the building or to avoid capillary action. (b) A step or break in a roof or gutter, across the direction of fall.	birds beak; tip; kick; break
Dropper		A spouting or gutter outlet.	pop
Dry film thickness	DFT	The thickness of a cured organic coating applied to a metal substrate.	film build
Ductility		The ability of metal to withstand elongation without fracture.	
Duopitch		A roof having two differing sloping pitches.	

Durability	The ability of a material to withstand the corrosive action of the elements, and comply with the structural and functional requirements of the design performance criteria for a specified time.	
Dutch gable	A type of roof frame that is partially hipped but which terminates as a gable.	
Dynamic pressure	Fluctuating load normally caused by wind forces.	
E2/AS1	An Acceptable Solution to the NZBC clause E2 External Moisture issued by the MBIE.	
Eaves	The protruding edge of a roof slope. When enclosed it is known as a soffit.	
Eaves gutter	An external roof gutter located under a roof overhang or the lower edge of a roof.	spouting
Edge protection	A guardrail or restraint designed to prevent a person from reaching over a roof edge or falling from a height.	
Elastic limit	The limit to which a material can withstand stress under load without any noticeable or measurable permanent deformation.	
Electrochemical series	The order in which metals react with one another in an electrolyte, with the electro-negative metal corroding in preference to the electropositive metal.	electromotive or galvanic series
Electrolysis	The chemical change or decomposition produced in an electrolyte by an electric current.	
Electrolyte	A solution such as water that contains ions, thereby becoming electrically conductive.	
Electrolytic cell	A cell containing an electrolyte which produces an electrochemical reaction when an electric current passes through it.	
Electrolytic corrosion	Galvanic corrosion commonly resulting from the contact of two dissimilar metals when an electrolyte, such as water, is present.	
Elevation	The part of a drawing which shows the front, side or end view of a structure.	
Emittance	The property of a surface to reradiate infra-red heat. Polished or shiny metal surfaces are poor emitters and dull dark surfaces are good emitters.	
EPDM	EPDM	A thermosetting synthetic rubber of ethylene, propylene, diene, monomer or terpolymer used as a resilient part of a sealing washer or as a roof membrane.
Erosion	The attrition of organic or metal coatings by natural weathering.	
Escarpment	A steeply sloping face separating two relatively level plains, where the plains' average slope is less than 5°.	

Eutectic point	The melting point of an alloy that is lower than the melting points of the elements or metals within it.	
Expansion joint	A joint in a long length of roof cladding, gutter, spouting or flashing designed to allow for thermal expansion and contraction.	
Eyebrow dormer	A roofed window structure with a curved roof projecting from a sloping roof surface.	
Fall	The slope of roof or wall cladding or gutter usually expressed in degrees, or as a ratio of vertical height to horizontal distance (e.g., 1 in 20 = 3°)	
Fanning	The spreading of roof or wall cladding at the gutter or ridge that results in the sheeting being out of square with the building.	sawtoothing; creep
Fascia board	A vertical board fixed to the bottom of the rafters, or trusses, to carry a spouting or gutter.	
Fascia gutter	(a) A square gutter formed to resemble a fascia. (b) A concealed eaves gutter system that interlocks with a vertical or near-vertical metal facing.	
Fasteners	Nails, screws, clips, and bolts, which are used to fix components of a roof assembly together.	fixings
Fatigue	The condition that induces weakness or cracking in a metal component by continued fluctuating stress, resulting in fracturing.	
Filler blocks	Shaped closed-cell plastic pieces inserted into the rib ends or pans of metal cladding, to prevent the ingress of wind, water and vermin.	seal; profiled foam; foam sealer
Fillet	A supporting infill, installed at the point where vertical and horizontal surfaces meet, to support flashings and to avoid the build-up of dirt and debris in a sharp corner.	
Film thickness	The thickness of paint or other coatings usually expressed in microns. (µm). Wet film thickness is the thickness of a coating as applied. Dry film thickness is the thickness after curing.	film build
Finial	A decorative element added to the end of a ridge, or the top of a spire or dome, to emphasise the feature.	
Fixing	The method of attachment of cladding to the frame using fasteners.	
Flame retardant	A material to which a substance has been added to reduce or retard its tendency to burn.	

Flashing	(a) A metal covering, built in to prevent moisture movement or the ingress of water to the inner parts of a building. (b) A component used to weatherproof, vermin-proof or seal the roof and wall cladding corner, ridge, perimeter, penetration, expansion joint, valley, gutter and other places where the roof covering is interrupted or terminated.	Apron; Barge; Back; Capping; Corner; Curb; Overcloak; Raking; Ridge; Secret; Sill; Skirt; Soaker; Soft-edge; Stepped.
Flat roof	A roof having a slope between 0° and 5°.	
Flux	A chemical liquid or substance used to clean and remove oxide or other films from metal prior to soft or hard soldering or brazing.	
Folding	A manufacturing method used to permanently deform metal over a small radius to the desired angle.	brake pressing
Freeboard	The height of the watertight portion of a gutter or profile above the design water level at maximum rain intensity. This is to allow for wave action or impediments in the sole of the channel that may otherwise cause overflowing.	
Free roof	A roof without enclosing walls; e.g., a carport.	
Fretting	Surface damage to metal or the coating between adjacent surfaces caused by movement and friction; e.g., during transportation. Normally, fretting only causes aesthetic damage.	
Fully supported cladding	Metal cladding that requires a solid substrate to provide strength for wind or point loads.	tray roofing; standing seam sarked roof
Gable	The triangular end wall surface of a building above the plate line where the rafters meet the apex at the ridge.	
Gable roof	A ridged roof having two slopes only, with a gable at each end.	
Galvanised steel	Steel protected against corrosion by a hot-dipped zinc-coating described as Z.	
Galvanising	The process by which steel is coated by dipping it into a bath of molten zinc, measured by weight in g/m ² or thickness in microns (µm)	
Gambrel	A roof that has two pitches on each side, similar to a Mansard roof.	
Gauge	The thickness of metal described in millimetres or inches, previously known as a non-measured number.	

Geothermal hotspot		A location that exhibits any geothermal activity such as steam, water or fumes emitting from the ground, hot water or mud pool.	
Girt		A structural horizontal wall member in a wall between columns used to fix or support wall sheeting.	
Good trade practice		Trade habits used by members of an industry, having a history of successful usage and having a higher standard than Acceptable Trade Practice.	
Grade		The mechanical strength of a metal complying with relevant standards.	
Groover		A hand tool used for seaming sheet metal. Also known as a Seamer.	
GRP	GRP	Glass fibre reinforced polyester translucent or opaque sheeting, used for roof lighting and manufactured to match profiled sheeting.	
Gutter		A channel formed to collect and carry water away from a roof, variously described as internal, external, box, eaves, valley, secret, hidden, and raking. <i>Spouting</i> refers specifically to an external gutter.	
Half-round		A spouting or eaves gutter having a half-circle cross-section.	
Hard Soldering		Using an alloy of silver and copper to bond two pieces of compatible metals together at approximately 735°, also known as silver soldering or brazing.	soldering; silver soldering; brazing
Head flashing		Flashing at the top of an opening or penetration.	
Hem		A flat but open metal edge folded 180°.	safety edge
Hertz	Hz	A metric or SI unit of frequency equal to one cycle per second used when cyclic testing metal roof and wall cladding.	
Hex head		A self-drilling or self-tapping screw with a hexagon (six-sided) head.	
Hidden Gutter		An internal gutter that runs parallel to the roof pitch. Hidden gutters are commonly found beside penetrations positioned close to the eaves.	
High strength		Unannealed metals that have a high yield strength relative to their ultimate strength.	
Hip		The external angle formed on a roof where two inclined faces meet.	
Hipped roof		A roof with a level eave and with its ends inclined as well as its sides.	
Holiday		A small pinhole or area where a liquid, applied paint coating or laminate film material is missing.	skip
Hook		An open hem used on a hidden under-flashing to prevent water ingress.	

Humidity		The amount of water vapour suspended in the air. The state or quality of being damp.	
Impermeable		A barrier preventing the passage of a liquid or vapour.	vapour barrier
Inert catchment corrosion		The phenomenon where rainwater or condensation, flowing over inert materials such as glass, plastic, or coated metals cause accelerated corrosion of downstream galvanised metal.	
Internal Gutter		A gutter inside the building envelope. In the COP terminology, this applies specifically to those that run transverse to the roof pitch.	Hidden gutter, Secret gutter
Interstitial condensation		Condensation that occurs within an enclosed cavity of a wall or roof.	
Jenny		A hand tool used to turn an edge on a curved flashing.	
Joggle		A double offset fold used to accommodate metal thickness.	crank
Kilonewton (kN)		A unit of force applied to a specific area equalling a thousand Newtons. As the unit value of a Newton is inconveniently small, such forces are commonly expressed in kilonewton.	Newton
Kilopascal	kPa	Kilopascal kPa A unit of pressure over an area equalling a thousand Pascals. As the unit value of a Pascal is inconveniently small, pressures are commonly expressed in kilopascals. 1 kPa = 1 kN/m ²	Pascal
Lap		(a) That part of a flashing or sheet that overlaps or covers any portion of the same shaped component, and variously described as overlap and underlap. (b) The total part of a flashing that laps another dissimilar component, including the cover.	
Lap tape		An adhesive strip made from UV resistant materials used as a joint sealant or part of a roof system.	
Lean-to		A mono-pitch or single slope roof attached to another structure, but at a lesser pitch.	shed roof
Leeward		The opposite direction to that from which the wind is blowing (windward). The side sheltered from the wind.	
Licensed Building Practitioner	LBP	A person issued with a renewable licence having satisfied the Building Practitioners Board that he or she meets the minimum standard of competence for each class of licence.	
Lightweight roof		A roof cladding which has a mass not exceeding 20 kg/m ² .	

Limit state	A design method having two parts: (a) Serviceability Limit State: The state when a building, or any part of it, becomes unfit for its intended use due to deformation or deflection. (b) Ultimate Limit State: The state associated with collapse or failure, or when a building or any part of it becomes unstable or unsafe.	
Load	The value of a force resulting from an action.	
Load spreading washer	A washer designed to give greater surface area to resist uplift pressures around the fastener head. In general, load-spreading washers should have a minimum thickness of 0.95 mm for steel and 1.2 mm for non-ferrous metal.	profiled washer; cyclone washer; top washer
Loads	Loads or actions that the structure or roof or wall cladding must be designed to support, as required by building standards or codes. (a) A dead load is the weight of the permanent structure including the roof. (b) A live load is a superimposed load such as foot traffic on the roof. (c) A wind load is that load imposed on the structure by the action of the wind.	
Local pressure coefficient	kl A factor applied to the design wind load due to the dynamic increase of the wind around the periphery of walls or roofs.	kl; local pressure factor
Long-run	Long length roll-formed roof and wall cladding fixed in one length without transverse laps.	
Low pitched roof	A roof having a slope between 5° and 10°.	
Macro-climate	The climate of a large geographical area.	
Maintenance	A planned set of activities regularly performed during the design working life of a structure to enable it to fulfil durability and functional requirements. Maintenance can be divided into two types: (a) Normal: That which can be undertaken without special equipment, e.g., washing. (b) Special: That which requires specialised skills or equipment.	
Mansard	A roof with two pitches, having a break in the slope, the lower part being steeper than the upper.	gambrel
Membrane	A non-metallic material used in conjunction with metal roof and wall cladding as gutters and penetrations, or as a fully supported roof cladding.	
Metal cladding	Formed metal commonly used in the roofing industry in New Zealand; including metallic coated steel, aluminium, stainless steel, copper, and zinc.	

Micro-climate		The climate of a small specified area; e.g., under eaves, near the seashore or in an enclosed cavity.	
Micro-cracking		The small cracking that occurs on external or tension bends of galvanised and aluminium/zinc coating on steel during forming, the extent of which is interdependent on coating thickness and bend radius.	
Micrometre	µm	A millionth of a metre, used as a measure of the thickness of metallic and organic films.	micron
Ministry of Business, Innovation and Employment	MBIE	The Government department regulating economic development, science and innovation, labour, and building and housing. MBIE also authorises BCA's and publishes the NZBC.	
Monel® alloys		Any of a group of nickel-based alloys, developed in 1905, containing between 29% and 33% copper, with small amounts of iron, manganese, carbon, and silicon. Monel alloys are stronger than pure nickel and resistant to corrosion by many agents, including rapidly flowing seawater. They can be fabricated readily by hot- and cold-working, machining, and welding. It is often used as rivets, fasteners or clips. Monel is a registered trademark of the International Nickel Company.	
Monopitch		A roof having one constant slope with no ridge.	mono-slope; lean-to
Nesting profiles		Cladding profiles that closely stack together.	
Netting		An open weave lightweight material used under roof cladding as support for underlay	mesh; wire netting
Newton	N	The force needed to accelerate one kilogram of mass at the rate of one metre per second squared in direction of the applied force.	
Neutral-cure silicone		A sealant with a neutral pH, that does not cause corrosion.	
Night sky radiation		A phenomenon where a roof can become up to 5°C colder than the ambient temperature by radiating heat to a clear night sky.	
Noble metal		A metal that is less active or likely to corrode when in contact with others.	
Non-ferrous		Metals made from elements other than iron.	
Notching tool		A hand tool used to remove a section of flashing that fits over a rib.	
Obtuse angle		An angle between 90° and 180°.	
Ogee	OG	A kind of sigmoid curve, somewhat shaped like an "S", consisting of two arcs that curve in opposite senses, so that the ends are parallel; it is often used in moulding.	

Oil canning	Distortion in the form of waviness or centre fullness in a profiled sheet.	canning; panning
Opalescent	Having shimmering, changing reflections, like opal.	
Opaque	Not see-through.	
Organic coating	The paint film of a pre-painted metal product or a laminate film of a laminated metal product.	
Overflow	An additional or alternative outlet for a gutter, spouting, rainwater head, or sump to harmlessly dispose of abnormal rainwater runoff or caused by blockages of the primary outlet.	
Oversized Hole	A larger than normal hole to allow for expansion or other reasons. When required, it is to be made using a 9 mm drill unless otherwise specified.	
Oxide	A chemical compound of oxygen and metal that will form as a film on the surface of metals on exposure to the atmosphere.	
Pan	The flat portion between the ribs of a profiled metal sheet.	
Pan fixing	The fixing of cladding through the flat pan, used when fastening wall cladding, stressed skin, and composite roof cladding.	
Pan Roof	A standing seam roof may be called a pan roof.	standing seam roof
Parapet	The part of a perimeter wall immediately adjacent to the roof, and which extends above it. A parapet higher than one metre is termed a parapet wall.	(incorrectly) enclosed balustrade wall
Pascal	Pa A unit of measure equalling one Newton per square metre	
Patina	A thin, visible, stable film of oxide, carbonate, or other chemical reaction coatings which forms on the surface of metal on exposure to the atmosphere.	
Peening	The permanent deformation or working of metals using a ball-peen hammer.	
Penetration	A projection through a roof or wall; e.g., vent pipe, air-conditioning unit window, or doorway.	protrusion
Penultimate	The next to last or the one before the last one.	
Perforation	Deterioration of metal due to corrosion or erosion that results in a hole.	
Performance	Quantitative and qualitative criteria which a product or system has to achieve to comply with the NZBC or other relevant Standards.	
Permanent ponding	When free water is evident for more than three days in spouting, gutters or on roof or wall cladding.	

Permeability		The measure of the rate of a porous material to permit gas or liquid to move through it in a unit time, area, and pressure. It depends on the density of both materials and the temperature.	
Permeable membrane		An underlay or other sheet material that permits the passage of water vapour.	breather type; permeable underlay.
Personal protective equipment	PPE	Safety equipment that is personal to the employee or the person to whom it is issued; e.g., safety boots, gloves, earplugs, etc.	
pH	pH	A unit-less logarithmic measure of acidity or alkalinity graduated from 0-14; pH 7 is neutral, below which is more acidic, above which is more alkaline.	
Pitch (1)		The slope or rake of a roof expressed in degrees from the horizontal or as a ratio of vertical height to horizontal distance, e.g., 1 in 20 = 3°. Also known as fall, and the tangent of the pitch angle. A roof is described by its pitch: (a) Less than 5° is flat. (b) From 5° to 10° is low pitched. (c) Roofs from 10° to 30° is pitched. (d) A slope of 30° to 60° is steep-pitched. (e) Over 60° is known as Elizabethan.	
Pitch (2)		The distance between the centres of two ribs.	
Pitch (3)		The distance between threads of a screw, usually expressed as Threads Per Inch (tpi)	
Pitched roof		A roof with a slope between 10° and 30° with a ridge at the highest point.	
Pittsburgh lock		A type of seam used to interlock two pieces of metal together.	lock- formed seam.
Plans and Specifications		Drawings, written requirements and other related documents according to which a building is to be constructed or altered.	
Point load		A load, normally downwards, applied either permanently or temporarily to a defined specific section of cladding	
Polycarbonate		A clear thermoplastic polymeric resin, formed into matching roof and wall cladding profiles, or curved flat sheeting used to provide natural roof lighting.	
Ponding		Any free undrained water retained for more than three days after cessation of flow on roof cladding, flashings, or a gutter due to insufficient fall. It can also be caused by permanent deflection or deformation of a roof.	

POP® Rivets	Pop rivets are typically used with sheet metal to securely connect two more components. It is a registered trademark owned by Stanley Engineered Fastening.	
Pre-curved	A metal cladding profile that is curved off-site, by progressive forming through a pyramid roll or crimp-curve machine.	
Pre-painted	Base metal strip or sheet, in line painted to give protection or aesthetic appeal prior to subsequent forming, shaping or fabrication.	prefinished; pre-coated.
Pressure coefficient	A ratio of the pressure on the surface area of a structure to the free dynamic pressure of the wind. It depends on the size, shape, height and the location of the building and the number and position of its openings.	Pressure Factor (internal, external, local, positive and or negative)
Pressure equalisation	A design of penetration flashing that relies on the complete inner seal of the penetration between it and the frame. A partial pressure equalisation design is termed pressure moderated.	
Producer statement	A detailed statement made by a manufacturer, designer or installer, about the durability, installation and performance of a product or building system, and which claims all manufacturing, design and installation will be or has been carried out in accordance with specific requirements.	
Product Certificate	A renewable certificate issued by an accredited certifier for a period of three years certifying the product, when used within its scope of use and installed under specified conditions, complies with Building Code requirements.	BRANZ appraisal; third party certificate; codemark
Profile	The cross-section of metal cladding, generically known as corrugated (sinusoidal), trapezoidal (ribbed), trough, tray, or standing seam.	corrugated (sinusoidal); ribbed (trapezoidal); troughed; boxed or tray
Profiled sheeting	Metal sheeting produced with corrugations or ribs to increase its strength.	long run
Profiled Washer	A metal washer formed to match the ribs of profiled sheeting to support the sheeting at the fastening under high wind loads.	Also see: Load Spreading Washer
Pucker	The unacceptable distortion of metal flashings due to an incorrect fit.	

Pull-out		The failure of a fastener when it is pulled out of the structure; e.g., by the uplift force of the wind.	
Pullover		The failure of the sheeting when it pulls over the head of the fastener or washer; e.g., by the uplift force of the wind.	Pull-through
Pull-up stop-end		An end closure of the pan of profiled cladding formed without cutting the ribs and forming pig lugs.	
Purlin		A horizontal secondary structural member supporting roof cladding.	
PVC	PVC	A clear or opaque polyvinyl chloride thermoplastic resin, formed into matching cladding profiles to provide natural roof and wall lighting, and rainwater goods.	
Quarter-round		A spouting or eaves gutter with a straight back, and a cross-section of a quarter segment of a circle.	quad; D
Radiation:		The transmission and emission of infra-red energy in the form of electromagnetic waves.	
Rafter		A sloped primary structural member that extends from the ridge to eave designed to support secondary members and the roof cladding.	
Rain collar		A conical flashing fitted over a pipe to weather the penetration.	rain hat; chinese hat; boot flashing
Rainwater goods		Any building product used for rainwater disposal including downpipes, rainwater heads, sumps, spreaders, eaves gutters, spouting, and valleys.	
Rainwater head		An external box designed to collect rainwater from a gutter.	rainhead
Red rust		The formation of a reddish-brown oxide on the surface of steel or iron.	corrosion; rust; cancer
Raking Spouting		Spouting that runs at an oblique angle to the roof.	
Reglet		A system of flashing between a wall and a roof that consists of a primary flashing and a counter flashing to provide additional weather protection.	
Relative humidity		The ratio of the mass of water vapour in a volume of air, compared to the value that saturated air could contain at the same temperature and pressure.	
Return period		The average number of years within which a given wind gust or rainfall is expected to be equalled or exceeded.	ARI; average return interval
Return stopend		The end of a spouting or gutter that has the profile face carried around the stopped end.	
Rib		A longitudinal up-stand produced by roll-forming, folding or crimping to strengthen or stiffen metal cladding.	crest upstand

Rib cap	A small metal flashing to weather a rib at a change of pitch.	prickles; sharks teeth; end cap; profile end
Ridge	(a) A long crest or chain of hills with sloping faces. (b) The top of a ridging or profile. (c) The level intersection point of two opposing planes of roofing.	crest.
Ridge cap	(a) A small capping to weather the join in the ridging used at a change of pitch or direction on metal cladding. (b) A formed metal tile used at a ridge.	(a) Hip-cap.
Ridge vent:	A prefabricated ventilator used in lieu of ridging that allows the escape of warm or moist air from a building.	vent-ridge.
Ridging	A metal flashing, roll topped, square or otherwise strengthened, which can be plain or soft-edged, used to cover the joint of the roof cladding at the ridge, apex, or hip-end.	
Roll	A piece of shaped timber used in fixing fully supported roof or wall cladding.	
Roll curved	Symmetrical cladding profile that is curved off-site by progressive forming through a pyramid roll machine.	
Roll-formed	A manufacturing process by which metal is progressively formed from flat sheet or coil into a profiled sheet by a series of shaped rolls.	long run
Roof	The surface of a structure or building designed to shelter the space below it against the elements and to discharge rainwater outside the building.	roofing
Roof light	Translucent profiled GRP, Polycarbonate or PVC cladding, or glass inserted into a roof surface provide natural lighting.	skylight; roof window; clear sheet
Roofer	A person who covers a roof.	
Roofing	The act of constructing or covering a roof.	roof

R-Value	R		U-Value
		R-values rate how much heat loss the material resists from passing through it; U-values rate how much heat the component allows to pass through it. R-values rate one single material while U-values measure entire components. For example, R-values measure how much heat loss passes through fibreglass insulation while U-values rate how much heat can pass through a window component (glass, air, vinyl sash). Typical insulation might have an R-value of 19 while a window might have a U-value of 0.35. $R = 1/U$. So a U-value of 0.35 would equal an R-value of 2.86. As you can see from this example, windows have a MUCH lower R-value than a properly insulated wall.	
Saddle		(a) A shaped piece of metal used to weather the junction between a horizontal and vertical surface. (b) A small metal support used to reinforce a damaged rib on the rib of roof or wall cladding.	
Safety edge		A small edge turned at 180° on the cut edge of a metal component in order to avoid personal or property damage.	hem
Safety harness		An assembly of interconnected shoulder and leg straps used where a person could fall from a height.	fall arrest harness
Safety mesh		A safety wire netting used to prevent workers from falling through a roof. It can also function as an underlay support	underlay support
Sarking		Timber boards or plywood fastened to rafters, trusses or purlins as roof support for metal cladding.	
Sawtooth roof		A trussed roof construction that is in the shape of the teeth of a saw, requiring gutters at the bottom of the near-vertical face.	
Scotch Ridge		The termination of a lower ridge where it meets the intersection of two valleys.	
Screw gun		An electric or battery driven driver, with a torque limiting or depth limiting device, used for driving self-drilling, self-tapping screws or other types of screw.	
Scupper		A horizontal opening in the side-wall of a gutter, spouting, parapet wall, or enclosed balustrade to allow drainage.	
Sealant		A single- or multi-component polymeric material used to waterproof metal joints, in conjunction with mechanical fasteners.	

Sealing washer	A rubber EPDM or neoprene washer, sometimes metal-backed, assembled on a fastener and used to prevent water from entering through a fastener hole.	metal-backed washer
Seaming	A method of joining two separate sections of metal by mating their two interlocking parallel edges, variously described as lock-formed, grooved, lock-seam, Pittsburgh lock, single and double welt, snap-lock, or knocked-up.	Lock-formed; grooved; lock-seam; Pittsburgh lock; single and double welt; snap-lock; knocked-up
Secret flashing	A flashing hidden from view or embedded within a wall or wall cavity.	
Secret gutter	An internal gutter that runs at an oblique angle to the roof pitch. This is commonly found where a roof runs into a raking wall or barge.	Secret valley gutter
Secret-fix	A roof or wall cladding system that has no visible or exposed fixings.	clip fix; hidden fix
Section properties	Values assigned to specific profiles determined by their geometrical shape.	
Secure footing	The ability of a person to walk safely, without assistance, on a roof with a pitch smaller than 35°, being dependent on the type of shoes worn and the type of surface.	
Self-drilling screw	A fastener that drills and taps its own hole.	TEK® screws; drill bit screws
Self-tapping screw	A fastener that self-threads when turned into a previously drilled hole; not the same as a self-drilling screw.	
SED Wind Zone	Specific Engineering Design Wind Zone as defined by NZS 3604.	
Shake	(a) A shake is a basic wooden shingle made from split logs. (b) An interlocking coated metal tile, impressed to resemble timber shakes.	
Shank	The original diameter of a nail, screw or bolt before heading, threading, or deformation.	
Shear	The scissor action of any tool used to cut metal.	
Shear force	A force that causes deformation by producing an opposite but parallel sliding motion.	
Shed roof	A lean-to roof having no hips or valleys and containing only one sloping plane.	

Sheeting	Any metal, GRP, or plastic roof or wall cladding.	
Shingle	(a) Thin, tapered pieces of wood primarily used to cover roofs and walls of buildings. Today shingles are mostly made by being cut, which distinguishes them from shakes which are made by being split out timber. (b) An interlocking coated metal tile, impressed to resemble timber, composition or modified bitumen shingles.	
Shoe	A downpipe angle at the discharge point.	elbow
Side lap fixing	The system by which one sheet is fixed to an adjacent sheet through the side of their lapping ribs.	
Sill flashing	A flashing at the bottom of a window or door opening or penetration.	tray flashing
Sinusoidal	A profile shaped with a series of arcs of a circle resembling part of a sine curve. When these are symmetrical about a centre line they are known as corrugated.	
Skew	A roof or fastener at an angle or out of square.	
Skew nailing	A method of driving nails in at an angle to the surfaces being nailed.	
Skillion roof	A pitched roof with the ceiling fastened and installed at a parallel pitch to the roof.	
Skirt	A separate over-flashing used to weather penetration curb flashings.	
Skylight	A unit of plastic sheet, glass or an Acrylic dome providing natural light through a roof.	roof window
Slip joint	An over-flashing fixed to one side only, to allow for expansion.	
Snips	A metal tool used to cut metal, having variously shaped cutting blades, variously described as straight, curved, gilbow, circular, aviation, left-hand, right-hand, or tinmans.	tin snips; shears
Snow-boards	A timber or metal platform built over a gutter to prevent blockage by snow or hail.	hail-boards; gutter-boards
Soaker	An under flashing, partially hidden, that prevents water ingress by means of hooked edges.	
Soffit	The enclosed underside of any exterior eave overhang.	eave
Soft Soldering	Using a lead/tin alloy that is melted to bond two pieces of compatible metals together at approximately 200°C;	soldering
Soft-edge	A compatible soft metal edging – usually lead, aluminium, or composite material – seamed onto flashings to provide a closure to profiled cladding and to exclude the weather and vermin.	

Soldering	A method of joining metals by forcing melted metal into the joint.	
Sole	The bottom surface of a gutter.	
Span	The centre distance between two fixing points. The clear distance between two supports is known as the clear span.	clear span
Spanbreaker	An intermediate supporting member placed under or over roof cladding at a rooflight or a penetration to minimise deflection or traffic damage on large spans.	mid-span support
Specular gloss	The measure of the reflective surface of an organic film at a defined angle.	
Spiral shank nail	A nail having its shank formed with helical grooves so that it rotates when driven.	twisted shank
Spouting	An external gutter.	1/4 round; quad; D; 1/2 round; OG; square
Spreader	A downpipe tee or elbow fixed at 90° to the roof slope and used to spread the discharge of stormwater over a greater area of the roof.	
Spring curving	An on-site method of installing straight lengths of profiled cladding to a convex or concave substrate.	drape curving
Springback	The elastic recovery of metal after deformation, which is more pronounced when forming high-strength metals.	
Square Stopping	When the wall-to-ceiling junction is stopped in the same manner as an internal wall corner junction. Square stopping can significantly reduce the amount of air and water vapour entering the ceiling cavity from the living areas.	
Stainless steel	A steel alloy containing a mixture of chromium, nickel and other trace metals to increase its durability.	
Standing seam	A fully supported metal roofing system that consists of an overlapping or interlocking seam that occurs at an upturned rib and is made by turning up the edges of two adjacent metal panels, then folding and interlocking them, once for a single seam and twice for a double seam.	pan roofing; tray roofing
Standing seam profile	A form of tray roofing installed on solid sarking, using traditional seaming tools.	tray profile
Static line	A rope, wire or rail secured between two points, to support any fall protection device.	
Steep pitch	A roof having a pitch between 30° and 60°.	

Step flashing	A flashing that weathers a step in the roof when the rafter length is greater than the length of sheeting that is available or advisable.	waterfall joint
Stepped flashing	A short sloping apron over-flashing set into a wall chase in brick, weatherboard, or block construction.	
Stop end	(a) That part of a trough of a sheet turned up at the high end of a run. Can be "pulled up" or "dog-eared". (b) Termination closure at the high or low end of a flashing. (b) An end closure for a gutter, spouting or flashing.	
Stressed skin	A term applied to roof or wall cladding that serves as a structural bracing diaphragm for a building.	
Strip	Flat metal, over 0.15 mm and under 3 mm thick, of any length and width – usually supplied in a coil.	
Strippable film	A plastic film applied to the surface of a metal sheet or strip to give temporary protection to the finish. It must be removed before prolonged exposure to sunlight.	
Subcontractor	A person or company who enters into a verbal or written agreement to perform specified work with the main or another contractor.	
Substrate	(a) The metallic surface to which a metal, organic or laminated film finish is applied. (b) The surface upon which the roof cladding is applied or fixed.	
Sump	An internal rainwater head used to connect a gutter to downpipes.	
Swage	A small raised flat rib in a sheeting profile used to minimise distortion caused by centre fullness, or residual or other stress in the sheeting.	stiffener
Swarf	Fine metallic filings or chips produced as debris from drilling, cutting, or grinding metal on a roof.	
Sweat	(a) Visible water droplets as condensation on a smooth surface such as metal sheeting. (b) A technique of soldering or brazing by the application of sufficient heat to fill the lap gap by capillary action with soft or hard solder.	
Swiss Gable	A gable roof in which the length of the ridge is longer than the eaves line.	Prow; Flying Gable
Symmetrical profile	A profile that has the same configuration on opposite sides of a horizontal centre axis line.	
Synthetic building paper	A synthetic roofing or wall cladding underlay.	
Tab	A small folded angle or projecting flap formed on a flashing to provide fixing.	

Tag-line		A rope that is used to guide a free-swinging load from a crane.
T-bend		The internal bend diameter expressed in terms of thickness used to define the external radius; i.e., 6 T bend = 4 T radius.
Tek® Screw		A proprietary name owned by Buildex for their self-drilling roofing screws for fastening into steel. Often misapplied to other manufacturer's steel fastening roofing screws and roofing screws generally. The name should not be used generically as that is misleading.
Temper		A hardness condition of metals, determined by a manufacturing process or subsequent annealing.
Tensile strength	UTS	The tensile limit when metal breaks under load, measured by the load divided by the original cross-section and expressed in MPa. (megapascals).
Terrain		The surface roughness of the ground described by its openness or by obstructions such as trees and buildings that influence wind speed.
The New Zealand Building Code	NZBC	The legal performance requirements as prescribed in the Building Act for building controls within NZ.
Thermal conductivity	k	The rate at which heat passes through a material expressed as the amount of heat that flows per unit time, area and distance.
Tile		An interlocking metal pressing, shaped to resemble a clay tile.
Tinman's Rivet		A small-headed solid fastener, suitable for peening requiring access to both sides.
Topography		The hills, valleys and plains that strongly influence and accelerate wind flow patterns and the wind design load on a structure.
Tornado		A violently rotating column of air attached to the base of a convective cloud descending to the ground and often observed as a funnel.
Total coated thickness	TCT	The measure of the total of the base metal thickness, plus any additional metal or organic coating.
Trade practice		Trade habits used by members of an industry, known variously as acceptable, good and bad.
Trade training		Tuition given to a trainee or workman by a qualified tradesman.
Tradesman		A workman or woman, having spent a prescribed period of time working at a trade; and who has been qualified by the successful completion of written and practical trade examinations.
Translucent		Allowing light to pass through, but not transparent.

Transparent		Clear, can be seen through.	
Transverse		A flashing or fastenings running horizontally across the sheeting.	
Trapezoidal		Profiled roof or wall cladding with longitudinal ribs angled similarly to a trapezoid.	rib profile
Tray		The flat draining area of a roof.	
Tray profile		A predominantly flat, secret fixed profile typically with one tray per sheet and narrow ribs which are locked together by friction	standing seam profile
Trough		The flat draining are of a roof.	traya
Trough profile		A predominantly flat, secret fixed profile; typically with two or three trays per sheet.	decking, secret fixed
Turn-up tool		A hand tool used to form stop-ends or to turn down the ends of metal cladding.	stop ender
Undercutting		The corrosion of a metal substrate under a paint film, caused by a score mark, edge or hole.	edge creep
Underlay		A flexible membrane laid under roof or wall cladding to control condensation or provide reflectivity.	building paper
Uniformly Distributed Load	UDL	Used as a measure of the wind load on metal cladding, usually expressed in kPa (kilopascals).	
Unwashed		Areas of roof or wall cladding protected from washing by natural rainfall at an angle of 45° by a projecting roof or overhang.	
Upstand		The vertical face of a flashing or stop end.	
U-Value	U	R-values rate how much heat loss the material resists from passing through it; U-values rate how much heat the component allows to pass through it. R-values rate one single material while U-values measure entire components. For example, R-values measure how much heat loss passes through fibreglass insulation while U-values rate how much heat can pass through a window component (glass, air, vinyl sash). Typical insulation might have an R-value of 19 while a window might have a U-value of 0.35. R = 1/U. So a U value of 0.35 would equal an R-value of 2.86. As you can see from this example, windows have a MUCH lower R-value than a properly insulated wall.	R-Value
Valley		A gutter at the intersection of two sloping areas of roof that meet at an oblique angle.	
Vapour barrier		A sealed impermeable membrane designed to eliminate the passage of water or water vapour.	vapour check

Vapour control layer	VCL	An impermeable membrane designed to minimise the passage of water or water vapour.	vapour check; vapour retarder
Vented		A cavity that provides some degree of water vapour diffusion and air movement.	
Ventilated		A cavity that has been designed to provide a significant flow of air or water vapour to the outside air, such as a ventilated ridge. The NZBC allows for drained, but not vented wall cavities.	
Walkway		A permanent or temporary structure placed over metal roof cladding to enable access without causing damage or imposing a point load on the cladding.	cat-walk
WANZ-WIS		The Window Association of New Zealand's Window Installation System.	
Watershed		A penetration over-flashing type that extends to the ridge.	back flashing; dry pan flashing
Weather:		(a) The state of the atmosphere at a given time and place, specified by variables including, wind velocity, humidity, temperature and pressure. (b) To cause a roof or flashing to shed water.	
Weathering		The visible change in a surface, such as the oxidation of metals, or chalking of pre-coated materials, due to atmospheric exposure.	Weathered
Weatherproof		(a) The ability to withstand exposure to weather without damage. (b) To protect a building from the elements.	Weathertight
Weathertightness		The degree of protection offered from the elements.	
Web		The vertical or near-vertical part of a rib.	
Welt		(a) An interlocking metal seam used when site fabricating roof sheeting. (b) Folds on flashings or roof cladding joining two adjacent metal sheets together at their edges without fasteners.	single welt; double welt; cross welt
Wet storage stain		Corrosion effects due to condensation or rain penetration of nesting profiles. Also known as White Rust for galvanised, Black Rust for Aluminium Zinc coating, and Black Stain for Aluminium	white rust; black rust
White rust		The visible white corrosion product found on galvanised coatings in protected, unwashed, cut edges or micro-cracked areas.	bloom
Wicking		The movement of water through a porous material by capillary action.	

Work hardening	The reduction of metal ductility caused by cold working or movement in service.	
Workman	A man or woman employed in a trade, who is or has learned trade skills from their employer, supervisor or a technical institute.	
Yield point	The first stress point at which some metals will plastically and permanently deform.	
Yield stress	The recorded stress at the point of yielding.	
Zinc aluminium coating:	Steel protected against corrosion by a zinc dominated zinc/aluminium alloy.	ZA; Galfan or Galvalloy

2.2 Domestic Cladding Terminology

2.2A Domestic Detail

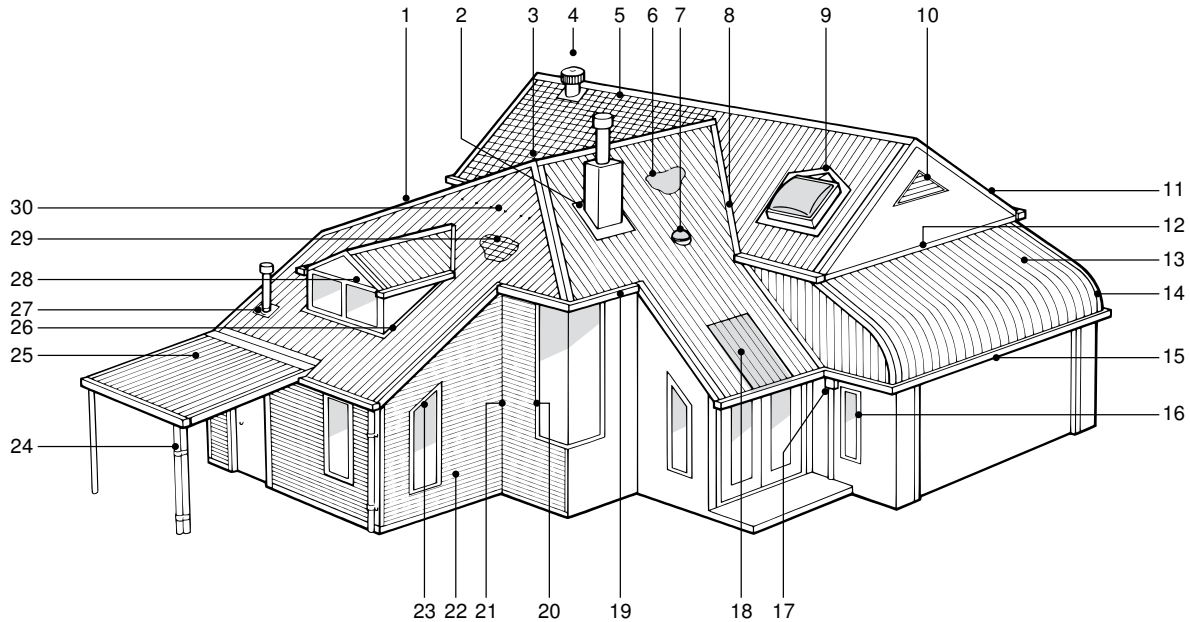

2.2B Domestic Nomenclature

1	Ridging	16	Recessed Window
2	Penetration	17	Rainwater Head
3	Ridge Cap	18	Roof Light
4	Ventilator	19	Concealed Gutter
5	Pressed Tiles	20	Butt Window Flashing
6	Underlay	21	Internal Corner
7	Tubular Roof Light	22	Horizontal Cladding
8	Valley	23	Flush Window Head
9	Cricket	24	Downpipe
10	Apex Ventilation	25	Secret-fix Roof Cladding
11	Barge	26	Apron
12	Apron	27	Collar Flashing
13	Roll Curving	28	Dormer
14	Curved Flashing	29	Safety Mesh
15	Fascia Gutter	30	Fixing Patterns

2.3 Industrial Cladding Terminology

2.3A Industrial Detail

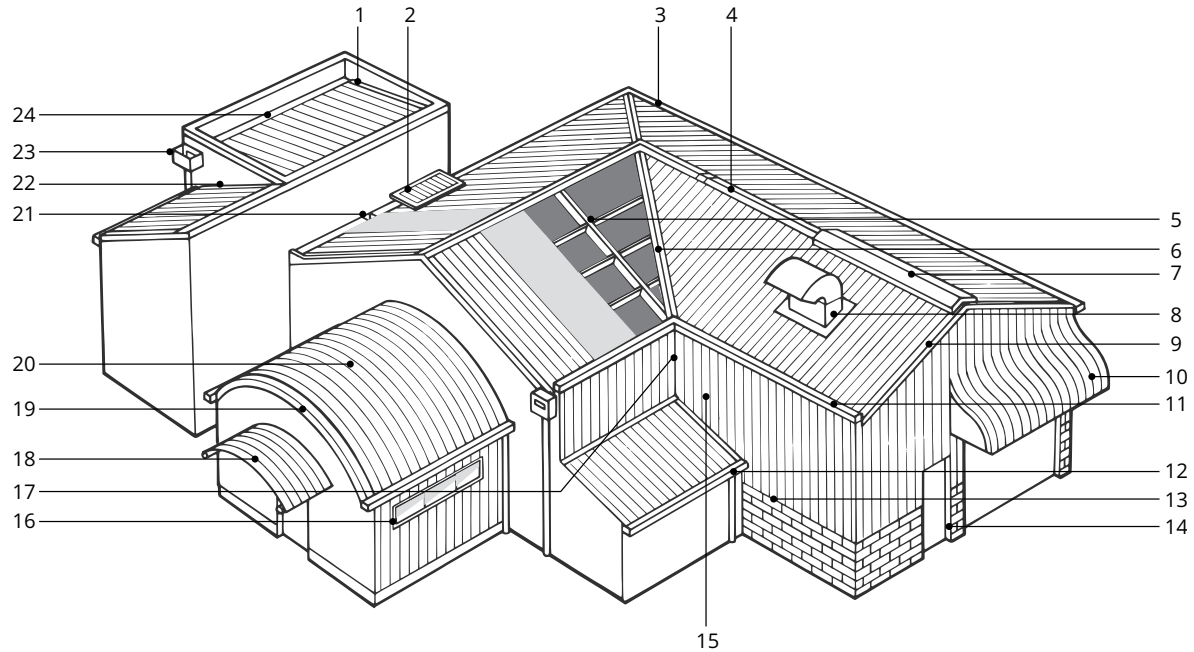

2.3B Industrial Nomenclature

1	Apron flashing	13	Sill flashing
2	Hail board	14	Door jamb
3	External gutter	15	Vertical cladding
4	Ridging	16	Window jamb flashing
5	Purlin spacing	17	Internal corner
6	Valley	18	Draped curve
7	Ridge vent	19	Curved flashings
8	Ventilation	20	Roll Curving
9	Barge flashing	21	Internal sump
10	Crimp curve	22	Two piece apron flashing
11	Parapet capping	23	Rainwater head
12	Fascia gutter	24	Internal gutter

2.4 Product Geometry

2.4A Sheet Profile Terminology

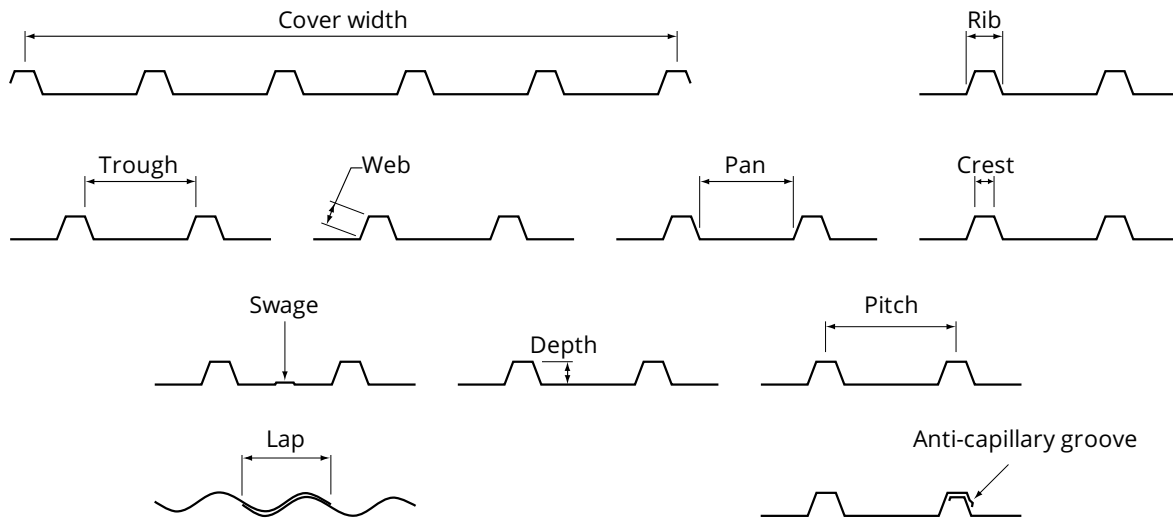

3

Structure

The information in this section explains the various factors used in calculating design loads and in resisting those loads to ensure roofs are structurally sound and meet the objectives of NZBC B1 Structure.

The designer must be familiar with the performance requirements of the New Zealand Building Code (NZBC) Loads can be calculated in accordance with the appropriate standard and maximum spans and fastening patterns specified according to manufacturers' literature, or for designs to NZS3604:

- G550 Steel Cladding Fastening Pattern Tables, and
- Aluminium Fastening Pattern Tables

For SED projects to AS/NZS 1170, designers can use:

- Steel Cladding Wind Load Span Graphs, and
- Aluminium Cladding Wind Load Span Graphs.

It is the responsibility of the roofing contractor to install roof cladding according to the design and raise any concerns with the designer before commencement.

3.1 NZBC Clause B1 (Extract)

Source: New Zealand Building Code Clause B1 Structure

3.1.1 Objective

B1.1 The objective of this provision is to:

- Safeguard people from injury caused by structural failure.
- Safeguard people from loss of amenity caused by structural behaviour.
- Protect other property from physical damage caused by structural failure.

3.1.2 Functional Requirement

B1.2 Building elements shall withstand the combination of loads that they are likely to be subjected to through construction or alteration, and throughout their lives.

3.1.3 Performance

B1.3.1 Building elements shall have a low probability of rupturing, becoming unstable, losing equilibrium or collapsing during construction or alteration, and throughout their lives.

B1.3.2 Building elements shall have a low probability of causing loss of amenity through undue deformation, vibratory response, degradation, or other physical characteristics throughout their lives.

B1.3.3 Account shall be taken of all physical conditions likely to affect the stability of building elements including:

1. Self-weight.
2. Imposed gravity loads arising from use.
3. Temperature.
4. Earth pressure.
5. Water and other liquids.
6. Snow.
7. Wind.
8. Fire impact.
9. Differential movement.
10. Influence of equipment services and non-structural elements.
11. Time dependant effects including creep and shrinkage.

B1.3.4 Due allowance shall be made for

- the consequences of failure,
- the intended use of the building,
- effects of construction activities,

- *variation in the properties of materials, and*
- *accuracy limitations inherent in the methods used to predict the stability of building elements*

3.2 Standards

Roof and wall cladding must structurally comply with the performance requirements of NZBC Clause B1 Structure. Loads may be calculated in accordance with AS/NZS 1170 (Loadings Standard), and these loads are used to develop prescriptive solutions such as found in NZS 3604 Timber Framed Buildings and NASH Standard for Light Steel Framed Buildings.

3.2.1 AS/AZS 1170.2:2011

Designers should be familiar with the current Loadings Code, including amendments. Manufacturers' printed technical literature, using different criteria or test values and superseded Standards can information that is not compatible with the latest requirements.

The Loadings Code identifies four load categories relevant to metal roof and wall cladding.

- **Wind actions:**
- *Wind imposed inwards forces (pressure) where the wind is slowed, and outward pressures (suction) where the wind accelerates. The shape of the structure induces local pressure factors where pressure is concentrated. Internal pressures may also be generated within a building.*
- **Permanent action:**
Dead load is the permanent weight of the roof structure and the permanent part of an imposed load, such as an air conditioning unit.
- **Imposed action:**
Live loads are variable loads imposed on the building by its occupants and contents, such as a person standing on the roof (point load).
- **Induced actions:**
Loads such as wind, snow or ice, and ponding rainwater.

When a structure, or part of it, fails to fulfil its expected basic functions, it is said to have reached a limit state; the two limit states are Serviceability Failure and Ultimate Failure. (see [3.7 Modes of Failure](#).)

3.2.2 NZS 3604:2011

NZS 3604 Timber Framed Buildings is an acceptable solution to comply with the NZBC for light timber frame buildings not requiring specific design.

It contains prescriptive dimensions for purlin spacing and fasteners, based on maximum design wind speeds of Low (32 m/s), Medium (37 m/s), High (44 m/s), Very High (50 m/s), or Extra High (55 m/s). The load calculations for NZS3604 were based on a simplified interpretation of AS/NZS 1170. These values can be used for calculation of loads on the cladding of structures designed using NZS 3604.

NZS 3604 includes:

- Timber frame construction.
- Height from lowest ground to the highest point on the roof may not exceed 10 m.
- A snow load may not exceed 1.0 kPa, although Section 15 of NZS 3604 does provide additional criteria for 1.5 kPa and 2.0 kPa snow loads.

NZS 3604 excludes:

- buildings dedicated to the preservation of human life;
- buildings which may host crowds;
- publicly owned buildings containing high value contents; and
- curved roof construction.

Because the buildings covered by this standard are limited in size, wind loads include a local pressure factor of 1.5 kPa over the entire structure, rather than varying factors according to the position on the roof as required by AS/NZS 1170.2:2011.

3.2.3

NASH Standard

Nash Standard Part 2 is cited in B1/AS1 as an Acceptable Solution for light steel framed buildings within a scope similar to that of NZS 3604

3.3 Performance

A structural steel member typically comprises elements named webs and flanges. In a roofing profile the sides of the rib act as a web, and the pan and crest act as flanges.

3.3A Profiled Steel – Flanges and Webs

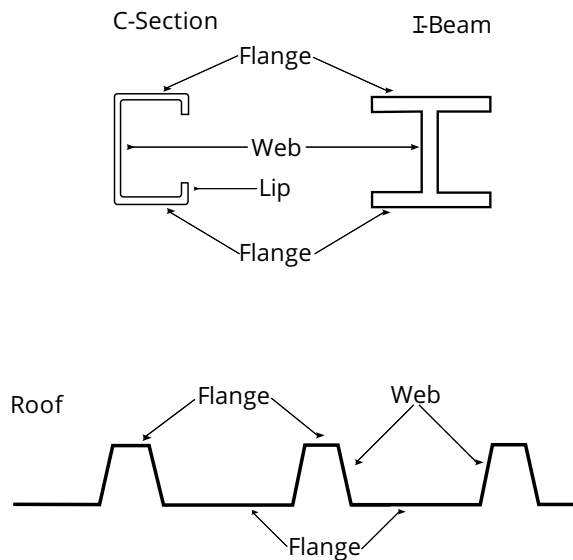

Steel is strong in tension but can be weak in compression if the profile is not optimised.

Profiled metal cladding acts as a beam, which derives its strength from the ability of its flanges, separated by the web to resist tensile and compressive forces. This strength can only be maintained while those parts in compression are restrained from buckling.

The geometry of the profile shape, together with the material thickness and strength, determines the load capacity of the profile. Manufacturing variations of profile shape from that tested will produce different results under load in pierced fastened profiles, and may produce vastly different results in clip fixed profiles.

3.3.1 Section Properties

Profile strength can be determined by analysis of sectional properties, but this will not accurately predict their performance under load, as the profile shape, and therefore the sectional properties, change during deflection. *Only physical testing can prove the actual capabilities of the profile.*

3.4 Profiles

Profile families can broadly be segregated as pierce fastened (corrugate, trapezoidal), and secret fix (tray and trough). Within these broad categories there are subsets.

3.4A Pierce Fastened Profiles



Corrugate – Minimum Depth 16.5mm



Asymmetrical Trapezoidal Low Rib – Minimum Depth 19mm



Asymmetrical Trapezoidal – Minimum Depth 30 mm



Asymmetrical Trapezoidal – Minimum Depth 45 mm



Trapezoidal Symmetrical – Minimum Depth 19 mm

Symmetrical corrugate or trapezoidal profiles have the advantage of being more easily curved around a radius. Because the ribs are necessarily close together, they have the disadvantage of roof traffic loads having to be spread over two crests, and they have a lower run-off capacity.

3.4.1 Corrugate Profile

The corrugated profile has been used in New Zealand for over 150 years and there has been only one significant change during that period.

In the 1960s the steel grade used for roof and wall cladding changed from low-strength steel (250MPa or G250) to high-strength steel (550 MPa or G550). The number of corrugations also changed from 8 to 10.5, which enabled the sheets to be laid either side up, as opposed to over-and-under.

The standard corrugation profile is 17.5 mm deep crests at 76 mm spacings, but smaller and deeper alternatives are also available.

Corrugate cladding is formed with a slightly asymmetrical overlap profile to a capillary barrier.

3.4.2 Trapezoidal Profile

The trapezoidal shape provides greater water carrying capacity and provides greater spanning capabilities than corrugate profile.

The angle and height of the trapezoid rib determines the profiles performance under compression. A deeper rib generally gives improved performance, but lowers the effective coverage of the sheet.

Trapezoidal profiles are available with different ribs heights (see [3.4A Pierce Fastened Profiles](#)).

3.4.3 Miniature Profiles

Various miniature cladding profiles are manufactured in New Zealand, the most common being known variously under the names of mini-corrugate, sparrow iron, baby iron and mini-iron.

Mini-corrugate is sometimes used for small roof areas, such as spires and awnings. It is most commonly used for wall cladding, parapets and internal linings where studs are normally spaced at 600 mm centres or less.

Some miniature trapezoidal profiles are also manufactured specifically for wall cladding.

3.4.4 Secret-fixed Profiles

3.4.4A Secret-fixed Profiles

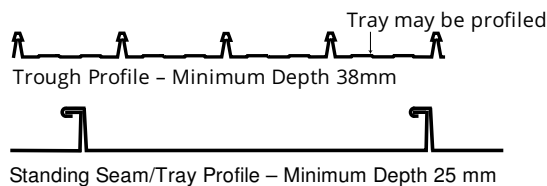

Secret fixed profiles are attached to the structure by clips rather than by pierce fasteners. This allows for freer thermal movement and minimises the number of penetrations in the cladding. The steep sided ribs and wide pans typical of secret fixed profiles gives greater water carrying capacity, and facilitates watertight flashing design.

Traditionally they were used for pitches as low as 1° but due to durability issues caused by deflection and resultant ponding the recommended minimum pitch is now 3°.

Trough sections generally have 2 to 3 pans or trays 180 – 250 mm in width. Tray roofing has a single pan of up to 550 mm in width.

Standing Seam is a subset of tray roofing. Standing seam roofs are based on traditional manufacturing methods (using folding and hand tool rather than roll forming), but now they are available roll-formed in most iterations. (See [15.4 Tray Roofing](#))

3.4.5 Material Grade

To test for tensile strength the material is subjected to a longitudinal (stretching) load, and values are taken for yield strength (when it permanently deforms) and tensile strength (when it breaks). Elongation is also measured during this test.

The minimum tensile strength defines the grade of steel, eg, G550 for high-strength light gauge steel, but to comply with this grade the yield strength and elongation must also fall within defined parameters.

Yield strength is an important determinant of the strength of a profile, along with profile shape and material thickness. High tensile material will have more resistance to failure such as buckling around the fastener under wind uplift, pull-through of the fastener head, or buckling under foot traffic load. However, tensile strength has a negligible effect on deflection under load.

Where 0.55 material is specified for straight corrugate or trapezoidal roofing, it is unacceptable to substitute G300 for G550 grade material as the resultant profile will have little strength advantage over 0.40 mm G550.

Aluminium is defined by a hardness grade ranging from H32 to H38. Typically, H34 is used for flashings, severe profiles such as trough sections, and profiles that are to be curved. Most corrugated and Trapezoidal profiles are manufactured using H36.

It must be remembered that the alloy also affects strength. H36 aluminium in 5005 or 5025 alloys, which are typically used in New Zealand, will have considerably greater tensile strength than the same grade in a 3000-series alloy.

3.4.5A End Use for Typical Alloys

Material	Grade	Typical End Use
Steel	G300	Flashings, ridging, spouting, curving, some trough sections.
	G550	Corrugated and trapezoidal profiles, some trough sections.
Aluminium 5505/5025	H32	Lock seaming
	H34	Flashings, curved roofing, trough sections, and tray roofing.
	H 36	Flashings and profiled roofing, trapezoidal sections, and corrugate.

3.4.5B Tensile Testing

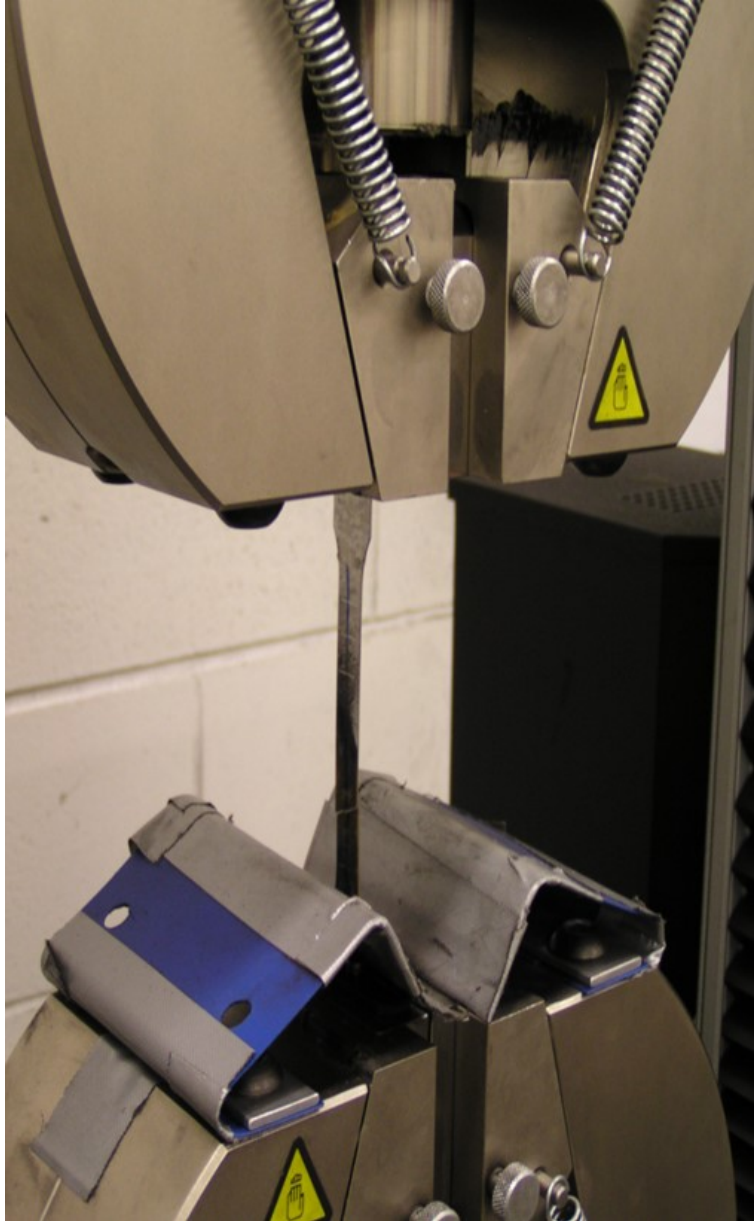

3.4.5C Typical Result for G500 Steel

NEW ZEALAND STEEL - TECHNICAL SERVICES LABORATORIES

*** TENSILE TESTING RESULTS ***

DATE: 08/03/2007 SHIFT: D MACHINE: Instron 5882 TESTER: GT LAB REF No.: AX374

Reference (Comments)	Status Code	Dir/ Pos	DIMENSIONS			RESULTS										Miscellaneous														
			Thickness Nom. mm	Width Act. mm	Length Dev. %	UYS	LYS	PRF	TSL	YE	UE			TE	R	Type	Y/T	Rate E-3	Hness Rwell	Result	EXT	XMT								
LN 650697		LC	0.000	0.440	0	12.48	77.00	677	673	673	683												8.4	E	99	0.8	82B	No Check	0	T

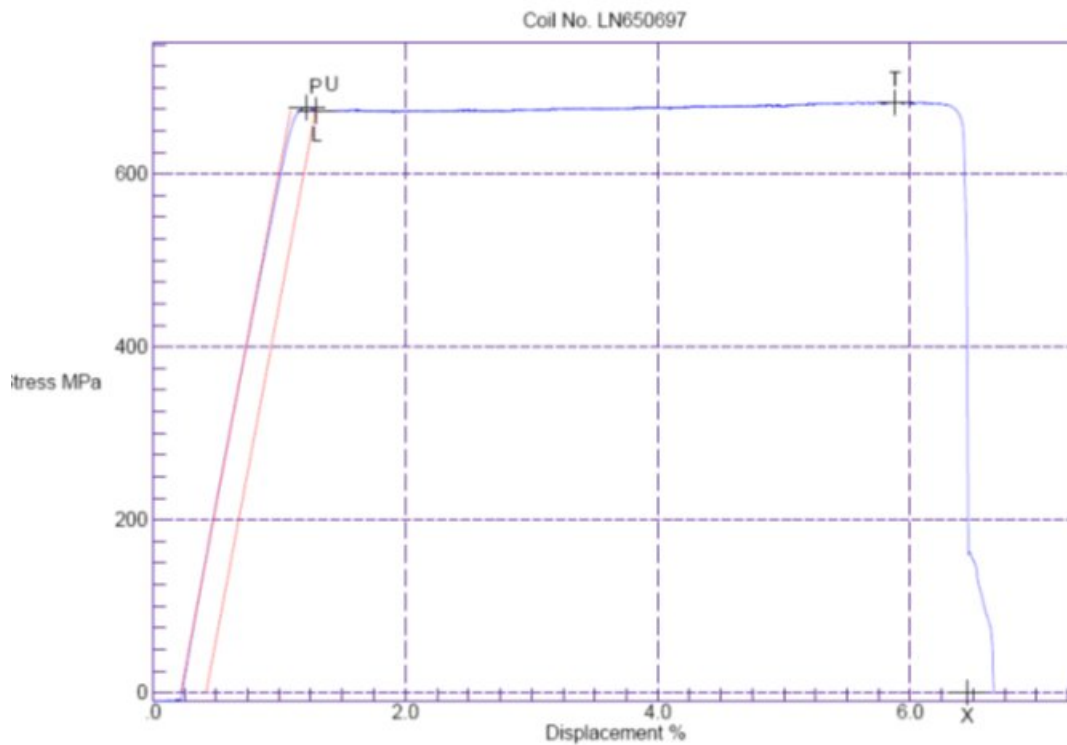

3.4.6 Material Thickness

Material thickness has a great bearing on load capacity and buckling resistance. For residential buildings, 0.40 mm thickness material is most commonly used for corrugated and trapezoidal profiles, and this will normally be sufficient to withstand the statutory wind loads at typical spans and fastener spacings in up to High Wind

Zones. In higher winds speeds, it is often more effective to use 0.55 mm material, rather than reducing purlin and fastener spacings.

Material with a 0.40 mm thickness is very vulnerable to foot traffic damage in most profile configurations and requires careful and accurate foot placement to avoid buckling. In residential buildings with high foot traffic expectancy or highly visible roofs, eg, multi-level mono pitch roofs, roofs with UV collectors, flues, aircon devices or chimneys that need servicing, or prestige housing 0.55 mm material should be selected.

For commercial and industrial applications, 0.55 mm is almost universally used on the roof, and 0.40 mm is most common on walls.

0.40 mm and 0.55 mm are not the only thicknesses available; 0.48 mm G550 is often used for high tensile trough sections, where it will often compare in strength to similar profiles manufactured from 0.55 mm G 300 material. 0.75 mm is often specified for heavy duty industrial roofs, and 0.63 mm is often manufactured for the Pacific Islands and other hurricane-prone regions. Other thicknesses are also available subject to minimum order quantities

3.5 Loads

The performance and optimal use of metal cladding is affected by the different types of load it is subjected to during the course of its lifetime. These loads can be broadly categorised as point load and uniformly distributed load (UDL).

Modes of failure and fastener loads are discussed in other clauses under the main clause [3 Structure](#).

3.5.1 Understanding Loads

The performance of profiled metal cladding under load depends on its ability to resist the tension (stretching), compression (squashing), and shear (sliding) forces that it is likely to be subjected to during the lifetime of the building.

3.5.1A Compression, Tensile and Shear Force

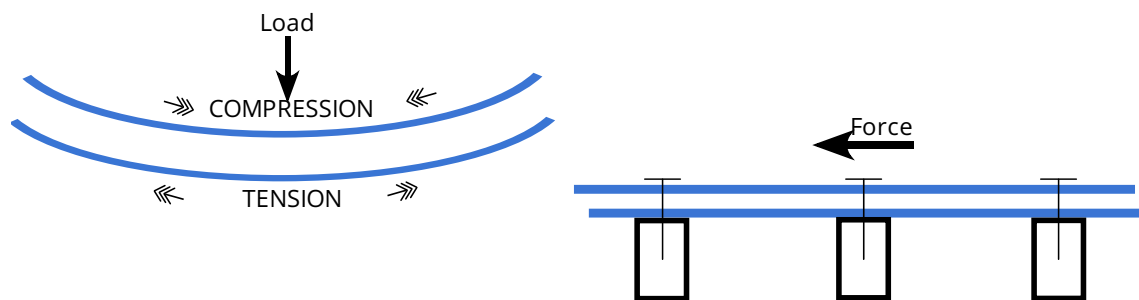

When a beam is subjected to bending, one flange will be under compression and the other under tension.

Loads acting on roof cladding are generally classified into two types: point load and uniformly distributed load (UDL). A point load is applied to a particular area, but a UDL impacts on the total area of the roof.

3.5.1.1 Continuity

Optimum performance of roof cladding under load depends on the continuity over several spans.

An adjacent continuous span assists the performance of profiled metal cladding, as continuity can reduce deflection up to 50%. In single spans the cladding is free to rotate at each support, but with continuity at a support the cladding is held down by an adjacent span; reducing the rotation and deflection.

3.5.1.1A Continuity

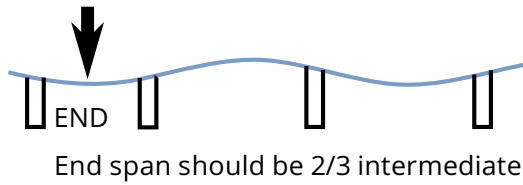

The end span of profiled metal cladding should be no more than two-thirds of the intermediate span for optimum performance under both point load.

3.5.1.2 Load Distribution

Load distribution greatly affects the deflection. A load distributed equally along the length of a beam (line load) will cause less deflection than the same load being applied to the centre of the beam.

3.5.1.2A Little deflection with a line load.



3.5.1.2B Increased deflection with Point Load.

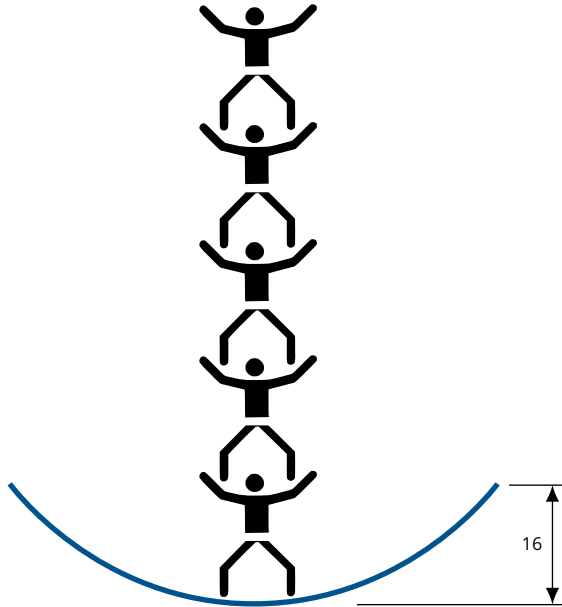

The depth of the profile of metal cladding is another important criterion in the design and use of metal roof and wall cladding. Given the same cross section area, the deflection of the profile will vary with the square of the depth, with the trade-off of higher buckling modes.

3.5.1.2C Deflection and the Square of Depth

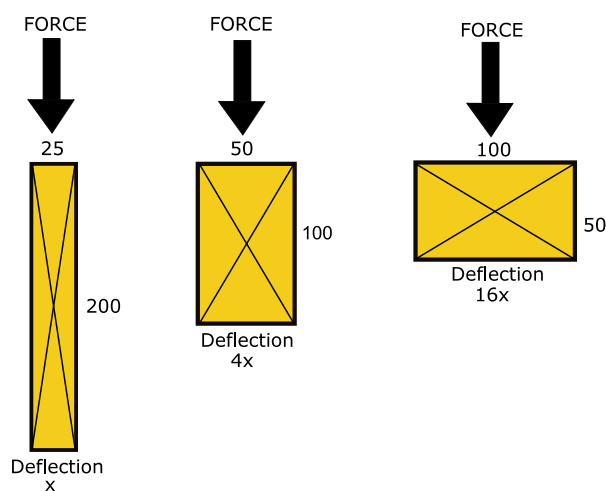

3.6 Types of Load

Loads acting on roof cladding are generally classified into two types: point load and uniformly distributed Load (UDL)

Cladding reacts differently to a point load and a UDL. A point load is applied to a particular area, but a UDL impacts on the total area of the roof.

3.6.1 Point Load

Most roofing profiles will resist far greater point loads when the load is applied to the pan of the profile rather than the rib. When the load is applied to the pan, the load is shared by the adjacent ribs. Alternatively, loads may be applied over two or more ribs.

Testing loads may be applied to the pan or the rib depending of the profile shape and the design criteria. See [3.7.4 Roof Traffic](#).

Trafficable roofs must be designed to withstand a point load which is representative of a worker with a bag of tools. It is calculated at 112 kg, which equals 1.1 kN force.

In the case of an imposed load, such as an air conditioning unit which is supported directly by the roof cladding, the unit weight per support and area of contact is calculated to arrive at point loads.

A point load on a roof is always positive or downward (+).

3.6.1A Point Load Test at the MRM



3.6.2 Uniformly Distributed Load (Wind or Induced Action)

A Uniformly Distributed Load (UDL) is commonly either a wind load or a snow load. These loads are variable and depend on factors such as the location, topography, and position on the structure, but do not often exceed 6 kPa. The most severe wind load is usually an uplift load, or negative (-), and snow load is a downward load or positive (+).

3.6.2.1 Wind Load

The wind load imposed on a roof structure is taken to apply at right angles to the roof cladding over a nominated area. The design wind load is affected by the design of the building and is modified using factors called pressure coefficients. Wind design load is measured in kilopascal (kPa); 1 kPa equals 1 kN/m².

3.6.2.1A Wind Uplift Load

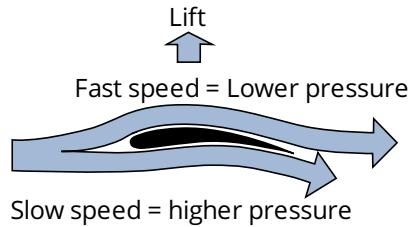

External wind pressure: Gable view

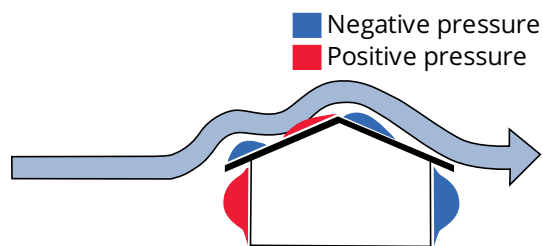

Under wind loads, inwards loads are resisted by the purlin or girts, whilst outward loads are only resisted by the fastener head or clip. Therefore, outwards load is the more critical figure.

Engineers calculate both the serviceability load and the ultimate load. They compare these values with the maximum failure loads of the products and systems they are considering.

Load/span data for standard corrugate, and low rib 5 and 6 ribbed trapezoidals is at the end of this section.

3.6.2.1B Load/Span Data clauses

Design	Steel	Aluminium
NZS 3604	3.10.1 G550 Steel Cladding Fastening Pattern Tables	3.10.2 Aluminium Fastening Pattern Tables
SED	3.11.1 Steel Cladding Wind Load Span Graphs	3.11.2 Aluminium Cladding Wind Load Span Graphs

Refer to manufacturer's load/span tables for all other profiles, which should give the maximum recommended load for continuous spans when tested as described in [17.1.3 Testing Procedure](#).

3.6.2.1C Sheltered by Trees, "Urban Terrain"



Scattered obstructions of a similar height or lower within 500 m from a building will considerably lessen wind speeds and lower design wind pressures.

3.6.2.1D Surrounded by flat ground, "Open Terrain"



Structures in open land such as flat pasture and playing fields, or by water, will be subjected to higher design wind pressures.

3.6.2.1E Topographical Influences



Terrain also has a big effect. Structures near the crest of a rise or on flat land near a steep face will have increased design wind pressure.

Wind Design Load is affected by building design factors such as building height, shape, proportions, orientation, and roof pitch. Permeability can also be a big factor; buildings with large openings on one side but completely closed on the other three sides will suffer high internal wind pressures. These internal pressures must be added to the suction load on the outside of the roof when calculating wind design load.

Local territorial authorities are usually able to give wind speed figures for a specific address in their area. All other factors, including topographical influences, internal, and local pressure factors must be considered by a suitably qualified professional to calculate the design wind load on a structure.

3.6.2.1.1 Local Pressure Factor (KI)

The local pressure factor (KI) is an important design consideration required by the Loadings Standard. The peripheral areas of roof and wall surfaces are subjected to greater uplift loads than the main body of the roof. Designers need to include local pressure factors in the calculation of wind loads on the cladding.

When determining fixing requirements to NZS 1170.2, the engineer should prepare a roof map showing purlin spans and local pressure factors for each section of the cladding.

When designing to NZS 1170 the local pressure factors are:

- 1.5—applied to the edges of all buildings at a dimension equal to 0.2 or 20% of the width or height of the building whichever is the least.
- 2.0—applied to the edges of all buildings at a dimension equal to 0.1 or 10% of the width or height whichever is the least.
- 3.0—applied to roof pitches less than 10°, at the corners where the dimensions in (a) intersect. It also applies to corners of walls where the building height is greater than the building width.

3.6.2.1.1A Local Pressure for Low-Pitch Roofs

Local Pressure (KI) factors as per AS/NZS 1170:2011

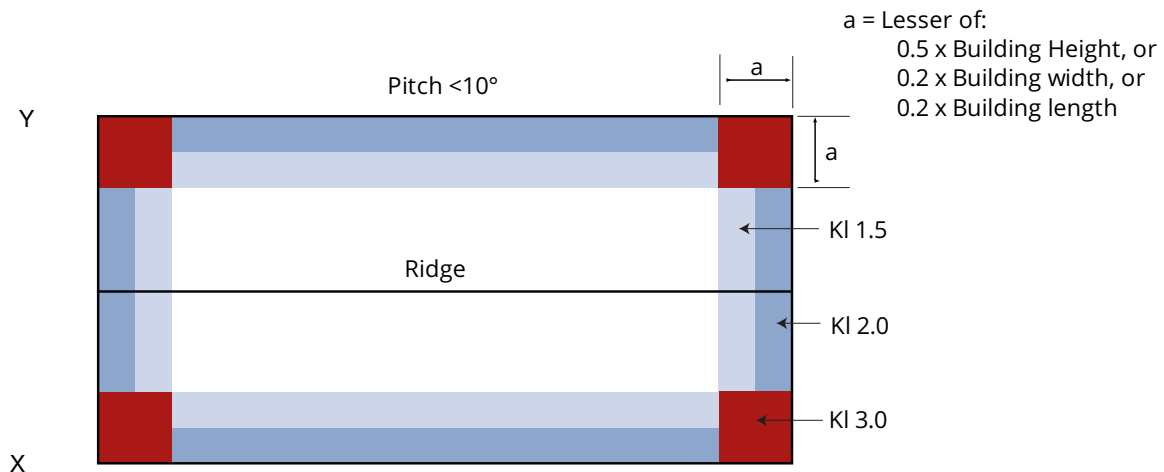

Pitches below 10° do not have local pressure factors at the ridge

3.6.2.1.1B Local Pressure Factors for Roofpitch over 10°

Local Pressure (KI) factors as per AS/NZS 1170:2011

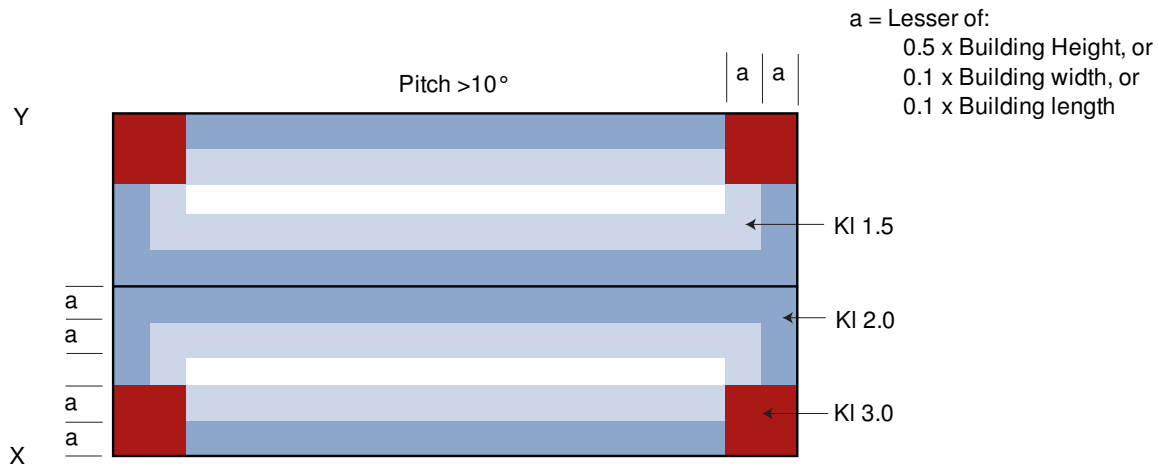

On smaller roofs the local pressure factors comprise a sizeable portion of the roof, especially where pitch exceeds 10 degrees.

3.6.2.1.2 Conversion of Wind Speed To Pressure

The basic formula for converting a wind speed to wind load is: $0.6 \times \text{velocity}^2 = \text{wind load}$. However, to get a true design wind speed is a lot more complex; various factors have to be applied including roof self-weight, internal pressure and local pressure coefficients.

The most influential of these factors is generally the local pressure factor, but internal pressure can also have a profound influence—particularly on unlined structures.

3.6.2.2 Snow Loads

Roof cladding design does not usually have to be altered for snow load, maximum snow load in New Zealand (under NZS 3604) is a UDL of 2 kPa. This is less than the upwards load in a Very High Wind Zone, however, as it is a downwards load, restraint is linear by the purlins, rather than point restraint by the fasteners, so greater capacity is achieved.

Any profile-gauge combination that will resist a wind load of Very High or Extra High Wind Zone with fasteners at each crest, will adequately resist a 2 kPa snow load. It may, however, be necessary to increase the strength of the structure to allow for induced snow loads.

NZS 3604 divides New Zealand into six zones where the maximum snow load is 2 kPa; areas above specific altitudes in these areas require specific design.

Projections such as gutters, flashings and chimneys need additional fixings and detailing to resist loads from sliding snow. It is normal to fit snow straps to residential gutters in snow prone areas.

3.6.2.2A Snow Loadings Map

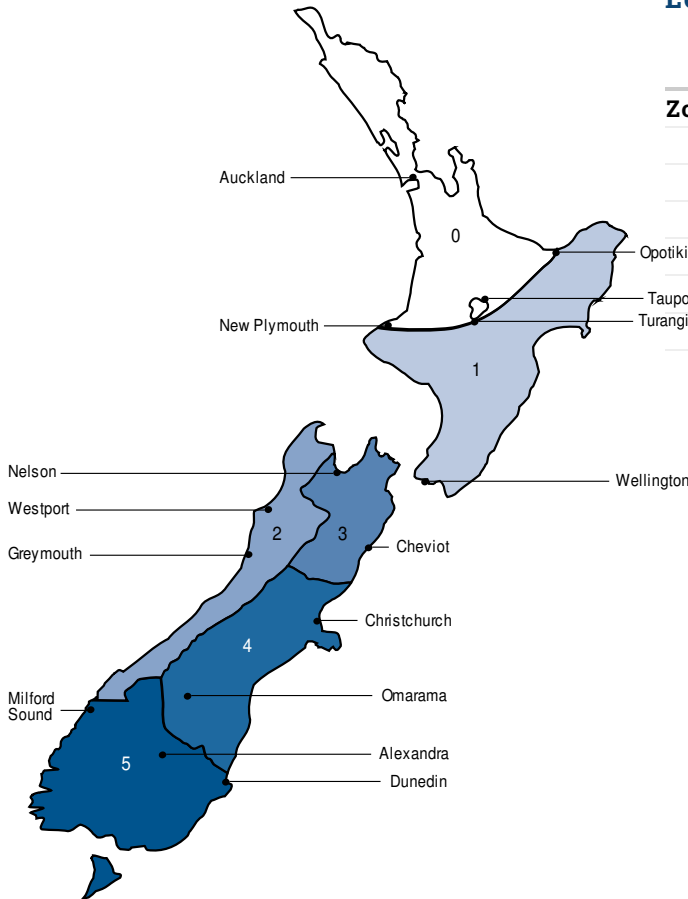

3.6.2.2B Altitudes for Snow Loading Design

Maximum Altitude as per NZS 3604				
Zone	Up to:	1.0 kPa	1.5 kPa	2.0kPa
0	Not Required			
1		400	600	850
2		400	600	850
3		400	600	850
4		100	200	350
5		200	300	400

3.6.2.3 Roof Weight

The self-weight of light-weight profiled sheet cladding should be included in the calculation of net wind load, but is a minor factor and, typically, works in the opposite direction to wind loads.

3.7 Modes of Failure

Serviceability limit is a state when a building, or any part of it, becomes unfit for its intended use due to deformation or deflection.

Ultimate limit is a state associated with collapse or failure, or when a building or any part of it becomes unstable or unsafe.

3.7.1 Serviceability and Ultimate Failure

Initial failure under wind uplift for pierce-fastened cladding is usually by local buckling of the rib crest adjacent to the fastener. While the cladding can still resist a load, this permanent deformation is liable to cause leakage at that point; therefore, it is a serviceability failure and is often the limit state for trapezoidal profiles. Medium and high rib trapezoidals may have ultimate loads as the determining factor.

Failure under wind load for clip-fastened cladding is usually by the clips de-indexing and the cladding sheets blowing off. This is an ultimate failure.

If a standard corrugate or low rib trapezoidal product passes UDL for serviceability it will comfortably exceed ultimate design load requirements. For medium and high ribbed trapezoidal, both serviceability and strength loads should be checked. Clip-fastened products are typically restricted by strength load only.

Point load resistance should also be checked against the expected roof traffic load of the finished structure. (See [3.7.4 Roof Traffic](#))

3.7.2 Deflection

Deflection is the temporary bending of roof or wall cladding that occurs under load when the material is subjected to forces within its elastic limits.

Deflection under distributed load is a voluntary limit of wall cladding, deformation causing residual deflection after application of point load is a serviceability failure of roofing.

3.7.3 Deformation

Deformation is a permanent alteration to the profile's shape that occurs when the material is taken beyond its elastic limits. This is most often seen as deformation under the fastener head after high outwards loads, or buckling of the rib after the imposition of a point load

3.7.3A Deformation Around a Fastener Head



3.7.3B Permanent Damage Around Fastener Head

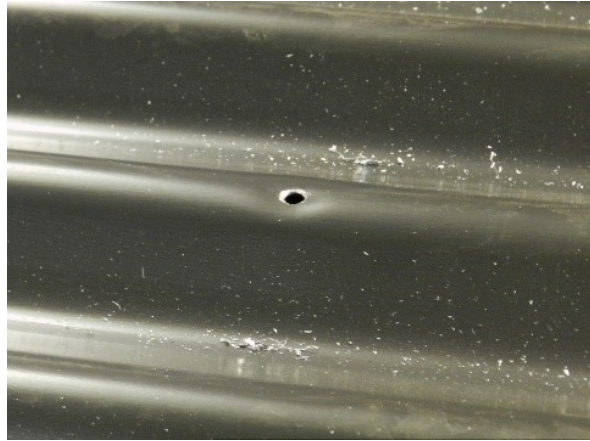

With high-strength claddings buckling failure is often quite sudden and severe once the point of yield is reached, while progressive deflection under repeated loads within the material's elastic limit is minimal.

Low-strength (G300) steel or non-ferrous metals can progressively yield under repeated heavy foot traffic, and are more prone to point load damage. This should be considered at the design stage. Machine roll-curved, crimp-curved cladding, and metal roof tiles are usually made from low-strength steels.

It is not acceptable for G300 steel to be substituted for G550 steel in products that are traditionally run from high-tensile strength material.

3.7.4 Roof Traffic

The designer must consider the degree and type of foot traffic that may be expected on a roof. The following requirements are subjective standards and must be considered in line with customer expectations, and building use and type.

More robust design than specified below (reducing purlin spacing or adding protection from mechanical action), is required for roofs that are regularly accessed, roofs used as staging by subsequent trades, or areas that are adjacent to access points, particularly step down access.

Type A – Unrestricted Access

Type A are roofs:

- that need to be regularly traversed by the roofer for access during installation;
- that will be accessed regularly by sub-trades;
- that butt on to walls or windows that may require maintenance;

- that have plant, chimneys, or solar installations requiring regular maintenance; or
- that require regular access for clearing gutters or spouting of debris.

For Type A roofs, the cladding must resist the load of 1.1 kN applied to the pan or a single rib, and a strength load of 2 kPa applied to the weakest point.

Type B – Restricted Access

Type B are roofs:

- that are simple in design and do not have to be regularly traversed by the installer;
- which are infrequently accessed by qualified trades people for maintenance; or
- with a pitch of more than 35°.

For Type B, roofs the cladding must resist the load of 1.1 kN applied to the pan or over two ribs and a 2 kPa load applied to the weakest point.

Type C – Non-Trafficable

Type C are roofs:

- where supports are required to be laid to support roof traffic, or traffic should take place within 300 mm of purlin lines,
- which have a pitch of 60° or greater; and
- including non-trafficable translucent roof sheeting.

For Type C roofs, the cladding must resist the minimum load of 0.5 kN applied to the pan or over two ribs.

3.7.5

Dead Loads

Any permanent load added to the roof cladding or structure is termed imposed; that includes air-conditioning equipment, solar installations, television aerials, anchor points, and walkways.

All loads must be supported on the rib of the profile or through the profile to the primary structure. Any attachment to the roof cladding must be compatible with the cladding, or isolated from it.

3.7.5A Correctly Installed Permanent Load



An air conditioning unit correctly installed on a roof, using durable and compatible materials.

No additional equipment must be directly connected to the cladding without considering the effect of increased dead and live loads.

When designing installations for placement on the roof, the roof traffic implications of installing and servicing such must be considered when determining point load resistance requirements.

3.7.6 Construction Loads

Construction loads on a building include the wind load on a partially clad or braced roof or building. Depending on the method and sequence of construction, it can be greater than the load on a completed building. Construction loads also include temporary localised loads from material storage, scaffolding, and tradespeople.

Other forces contributing to construction load include:

- The intensity of internal wind pressures due to a temporary absence of ceilings, walls and glazing.
- Storage of roof cladding on the structure. Bundles of roof cladding should be placed so they do not cause overstress in purlins.
- Any scaffolding above an existing roof must be designed to avoid damage to the roof structure or coatings, and be designed or sequenced to avoid wet storage corrosion. It is far better practice to stage jobs so that lower roofs are not used as a working platform for work on higher levels

3.7.6A Typical Rib Damage Due to Point Load



3.7.7 Fatigue and Brittle Failure

All metals may be subjected to fatigue under repeated heavy load conditions.

While high-strength steel is susceptible to fatigue, this seldom happens in practice. Aluminium brackets and clips have been known to fail by fatigue and this should be considered in designing such items.

Other metals, such as lead and copper, are restricted in length or overall panel size to avoid cracking by fatigue. Sharply folded corners should be avoided on these materials and the minimum radii requirements should be followed.

Hydrogen embrittlement can occur when folded items such as external gutter brackets are subjected to post-forming hot dip galvanizing. This can be avoided by forming to radii appropriate to the material grade and thickness being formed.

3.8 Fasteners

Most fastener failures happen due to negative load (or uplift) resulting in pull out of the screw from the support, or the screw pulling through the cladding or causing permanent deformation. Testing procedures are designed to closely simulate these conditions.

Product testing does not include pull-out of the screw, this should be checked independently.

3.8.1 Fastener Loads

Fastener failure by fatigue can occur when fasteners embedded in timber or hot rolled steel, are subject to frequent bending action by repeated thermal expansion forces. This is unlikely to happen to cold rolled steel purlins up to 2.5 mm in thickness as the thinner depth of connection of the screw into the purlin allows it to rotate, rather than bend.

3.8.1A Fasteners – Mechanical Properties

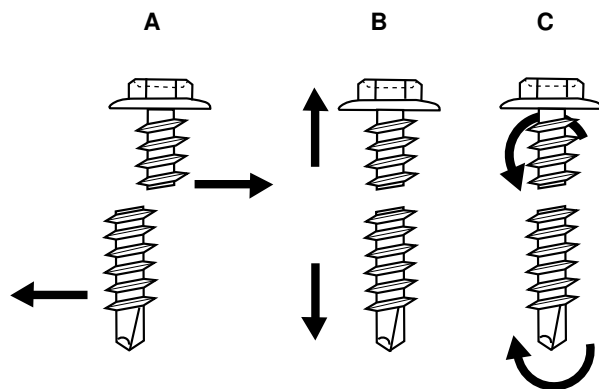

- A. Single Shear Strength (N)
The shear load required to break the screw
- B. Axial Tensile Strength (N)
The tensile strength to break the screw
- C. Torsional Strength (Nm)
The torque required to break the screw

3.8.2 Steel Purlins

A fastener penetration of three threads through the steel member is sufficient for the fastener to meet its full design capacity. Pull-out failure of screws must be checked when assessing a profile's load/span capacity.

The pull-out values of screws into light gauge steel battens or purlins varies greatly with thread design, pitch, and drill point shape. When fastening into light gauge steel, the pull-out values of the specified screw must be considered, and the installation must be completed with that type, gauge, and brand of screw. In light gauge steel under 1mm in thickness, it is also important to avoid stripping out the formed screw thread

3.8.3

Timber Purlins

Timber purlins generally require a fastener penetration of 30 mm. With this level of embedment, a screw equipped with a profiled washer though 0.55 material will fail by pull-through of the cladding before it fails by fastener withdrawal from the timber. Greater thicknesses of cladding may require specific design. For fastening into sarking or rigid air barrier less than 30 mm thick, the pull-out values for the specific screw and sarking material should be obtained from the supplier and required fastener pattern calculated.

3.8.4

Pull-over Values

Pull-over values for medium and high rib trapezoidal profiles must be checked against strength loads provided by testing.

Pull-over load depends on the head or washer size. For example, as 12# and 14# screw heads have approximately the same diameter, these screw sizes have the same design load value for pull-over. If the pullover load is likely to be exceeded, the options are to increase the metal thickness or use a load-spreading washer.

3.8.5

Load-spreading Washers

Profiled load-spreading washers spread high wind uplift-loads over a larger area around the fastener head. Using load spreading washers under the fastener can increase the load resistance of each fastener by up to 50%.

The type, size and stiffness of washers are critical for performance. Where performance data incorporating load-spreading washers is used, the specification of the washer must be quoted with the fastener.

In general, load-spreading washers should have a minimum thickness of 0.95 mm for steel and 1.2 mm for non-ferrous metal.

3.8.5A Load Spreading Washers

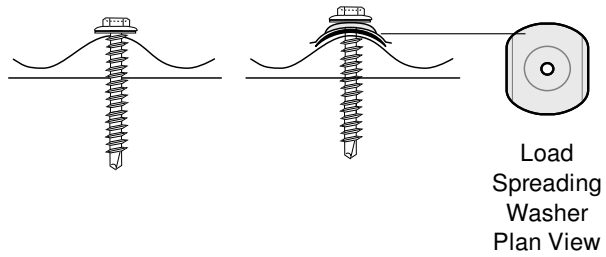

Where oversized holes are used to accommodate thermal movement of the sheeting, load-spreading washers should be used with sealing washers to ensure weather tightness.

3.9 Fastener Requirements and Overhangs

3.9.1 Purlin-Rafter Connections

For sprung curved roofs, the purlin/rafter connection must be increased at the eaves.

Long lengths of pierce fixed roofing will impose added loads to the purlin connection due to thermal movement of the roof.

3.9.1A Purlin to rafter fastener requirements for SG8 Radiata pine, complying with NZS 3604:2011

Rafter Spacing	Purlin Spacing	Low Wind Zone	Medium Wind Zone	High Wind Zone	Very High Wind Zone	Extra High Wind Zone
		Use 70 x 45 mm radiata pine on flat minimum				
		Use 90 x 45 mm radiata pine on flat minimum				
0.9	0.6	A	B	C	C	C
0.9	0.9	B	C	C	C	D
0.9	1.2	C	C	C	D	D
1.2	0.6	B	C	C	C	C
1.2	0.9	C	C	C	D	D
1.2	1.2	C	C	D	N/A	N/A

3.9.1B Purlin to Rafter Fastener Fixing Capacity

Type	Fastener	Fixing Capacity (kN)
A	1/90 x 3.15 gun nails	0.55
B	2/90 x 3.15 gun nails	0.80
C	1/10g x 80 mm self-drilling screw	2.40
D	2.10g x 80 mm self-drilling screws	3.45
E	1/14 g X 100 mm self-driling screws	5.50

3.9.2 Sheet Overhang

The maximum overhang for all corrugate and low trapezoidal profiles is 150 mm, unless a product has been specifically tested to withstand point load and design wind loads at a greater overhang.

The allowable overhang distance of various cladding profiles will depend on their section properties.

When using trapezoidal profiles, greater overhangs can be achieved by stiffening the edge of the

sheet in various ways; the most common being using a square gutter with a horizontal flange, but this should be fastened on every pan to achieve continuity.

The limit placed on low trapezoidal profiles with a stiffened overhang is 300 mm but it is not suitable for corrugate.

The overhang distance can be increased for some trapezoidal profiles with a rib height greater than 28 mm, but this distance must be proved by testing.

Where the cladding is fixed at a ridge or apron, the overhang distance can be increased to 250 mm from the end of the sheet, as the cladding is not subjected to the same point load or UDL and the load is shared with the flashing.

Point of access and expected roof traffic loads must also be considered.

3.9.3 Maximum Spans for Corrugate Wall Cladding

The maximum span for pan fastened wall cladding is generally governed by temporary deflection under load, rather than permanent deflection around the fastener.

3.9.3A Maximum Span for Wall Cladding: 5 Fasteners per Sheet (every second trough)

*Serviceability load governs

The deflection criteria used in this table is $\text{span}/120 + P/20$, where P = the space between fasteners. Higher deflection limits may be acceptable in certain circumstances.

Wind Zone	Load (kPa)*	Maximum Spans	
		0.40 m	0.55 m
Medium	0.93	1.80	2.10
High	1.32	1.50	1.80
Very High	1.72	1.40	1.60
Extra High	2.09	1.20	1.50

3.9.4 Fastener Patterns

Fastening patterns for the most commonly used profiles are designated in the following manner.

3.9.4A Corrugate Fastening Patterns

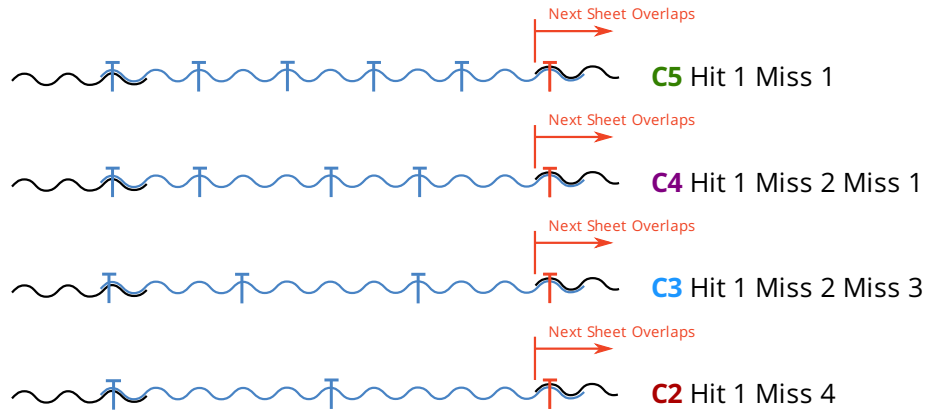

3.9.4B Fixing Patterns for 5 Rib Sheeting

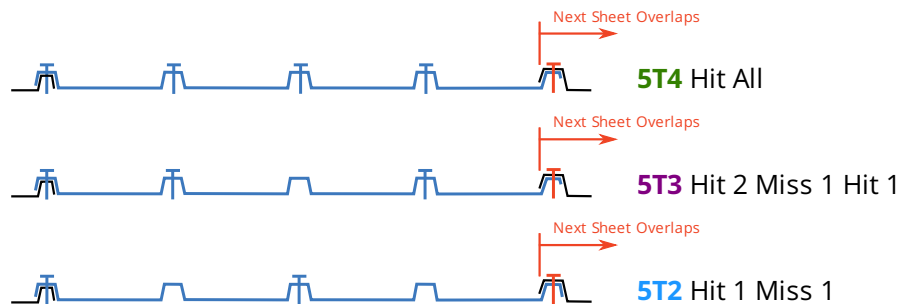

3.9.4C Fixing Patterns for 6 Rib Sheeting

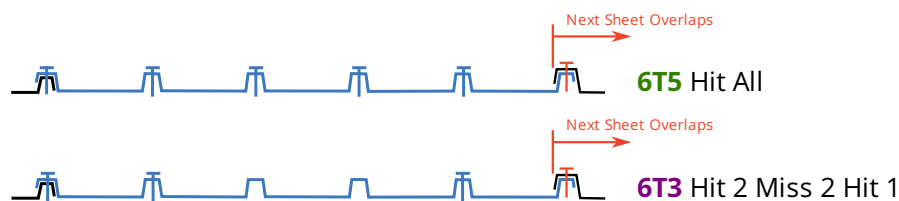

These fastening patterns should be used in conjunction with load span graphs.

The load on a purlin and a purlin/rafter connection is determined by the wind load and the area of roof the load is acting upon. Roof fasteners transfer wind uplift-loads to the purlins, which in turn transfer them to the primary structure.

Fastening to every second purlin may be within the roof's load/span range, but will double the load acting on the fastened purlins. All purlins must be fastened to unless alternate purlins are specifically designed to take the additional loads

3.9.4D Symmetrical and Assymetrical Fastener Patterns

Symmetrical fastener patterns are more effective.

Symmetrical fastener pattern

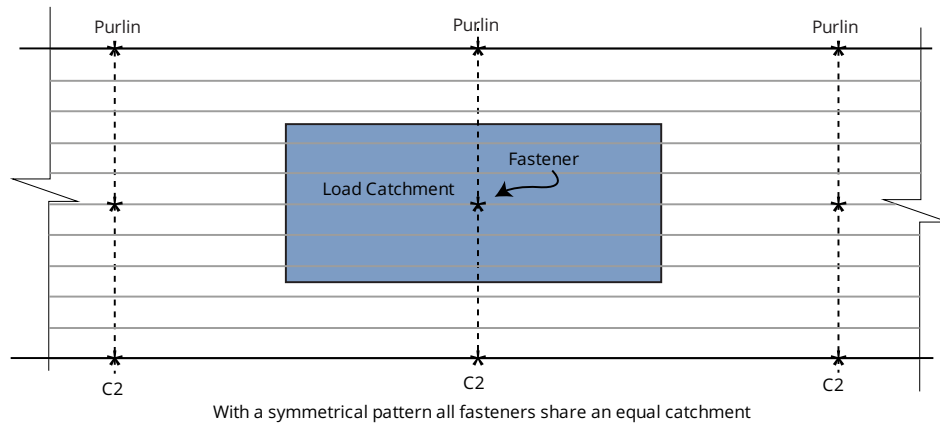

Asymmetrical fastener pattern

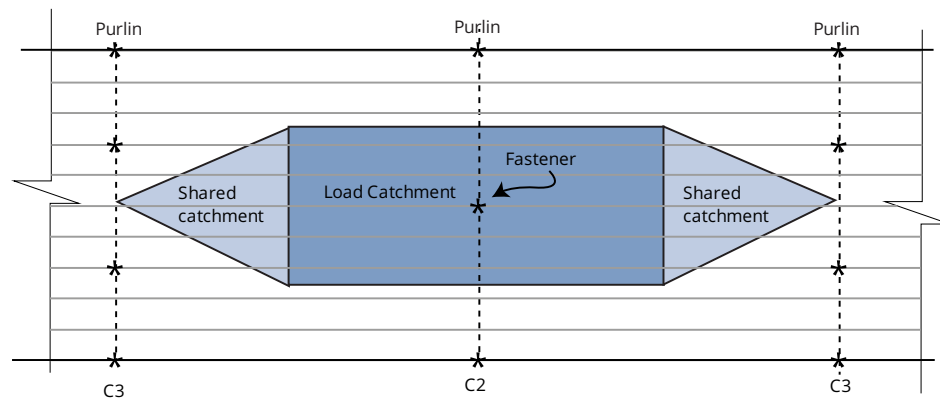

Because metal roofing has little transverse stiffness, unfastened crests will bow between fasteners. Therefore a fastener through a crest which is not fastened at adjacent purlins has a greater load catchment

3.10 Fastening Pattern Tables – Designs to NZS 3604

Fastening Pattern Tables should be read in conjunction with the constraint of access and the span at which the point load will be the limiting factor.

The performance of profiled metal cladding depends on the profile shape, thickness of the metal, the span, and the fastening type and pattern. These values can be greatly enhanced by using load-spreading washers or thicker material.

3.10.1 G550 Steel Cladding Fastening Pattern Tables

3.10.1A Wind Speed as per NZS 3604:2011 Timber Framed Buildings

Windspeeds below are the maximum ultimate limit state wind speed for each wind zone.

L	=	Low wind speed of 32 m/s	M	=	Medium wind speed of 37 m/s
H	=	High wind speed of 44 m/s	VH	=	Very high wind speed of 50 m/s
EH	=	Extra high wind speed of 55 m/s			
SED	=	Specific Engineering Design (not covered by NZS 3604)			

0.40 mm Corrugate G550 Steel (Min Depth 16.5 mm)

Access	Span (m)	Wind zone as per NZS 3604					Fastening Pattern
		L	M	H	VH	EH	
Restricted	0.6	C2	C2	C2	C2	C4	
Restricted	0.9	C2	C2	C3	C4	C4	
Non-Trafficable	1.2	C3	C3	C4	C5	N/A	

0.55 mm Corrugated G550 Steel (Min Depth 16.5 mm)

Access	Span (m)	Wind zone as per NZS 3604				
		L	M	H	VH	EH
Unrestricted	0.6	C2	C2	C2	C2	C2
Unrestricted	0.9	C2	C2	C2	C2	C3
Unrestricted	1.2	C2	C2	C3	C3	C4
Restricted	1.5	C2	C2	C3	C4	C4

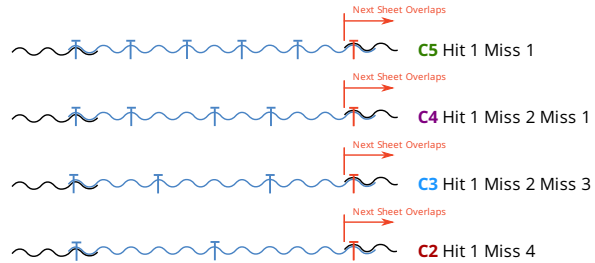

0.40 5 Rib Trapezoidal G550 Steel (Min Depth 27 mm)

Access	Span (m)	Wind zone as per NZS 3604				
		L	M	H	VH	EH
Restricted	0.6	5T2	5T2	5T2	5T2	5T2
Restricted	0.9	5T2	5T2	5T2	5T3	5T3
Restricted	1.2	5T2	5T2	5T3	5T4	5T4

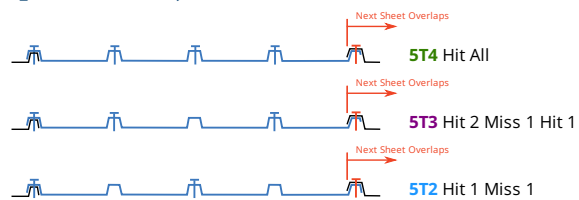

0.55 5 Rib Trapezoidal G550 Steel (Min Depth 27 mm)

Access	Span (m)	Wind zone as per NZS 3604				
		L	M	H	VH	EH
Unrestricted	0.6	5T2	5T2	5T2	5T2	5T2
Unrestricted	0.9	5T2	5T2	5T2	5T2	5T3
Unrestricted	1.2	5T2	5T2	5T2	5T3	5T3
Unrestricted	1.5	5T2	5T2	5T3	5T3	5T4

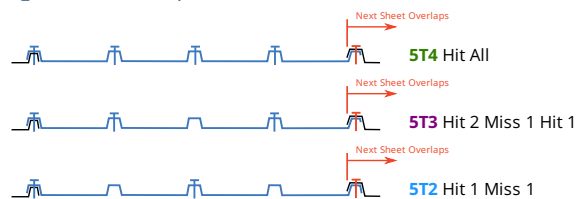

0.40 mm 6 Rib Trapezoidal G550 Steel (Min Depth 27 mm)

Access	Span (m)	Wind zone as per NZS 3604				
		L	M	H	VH	EH
Unrestricted	0.6	6T3	6T3	6T3	6T3	6T3
Unrestricted	0.9	6T3	6T3	6T3	6T5	6T5
Unrestricted	1.2	6T3	6T3	6T5	6T5	6T5

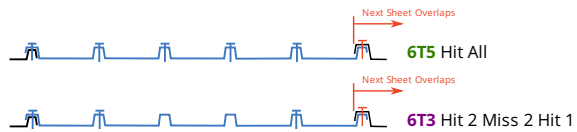

0.55 mm 6 Rib Trapezoidal G550 Steel (Min Depth 27 mm)

Access	Span (m)	Wind zone as per NZS 3604				
		L	M	H	VH	EH
Unrestricted	0.6	6T3	6T3	6T3	6T3	6T3
Unrestricted	0.9	6T3	6T3	6T3	6T3	6T3
Unrestricted	1.2	6T3	6T3	6T3	6T3	6T3
Unrestricted	1.5	6T3	6T3	6T3	6T5	6T5

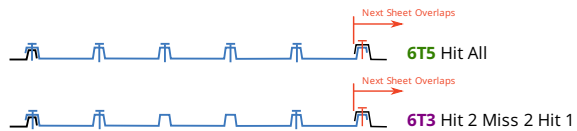

3.10.2 Aluminium Fastening Pattern Tables

0.70 mm H36 Corrugated Aluminium (Min Depth 16.5 mm)

Access	Span (m)	Low	Med	High			Extra High
				High	High	High	
Non-Trafficable	0.9	C3	C3	C3	C3	C3	C3
Non-Trafficable	1.2	C3	C3	C3	C4	C4	C4

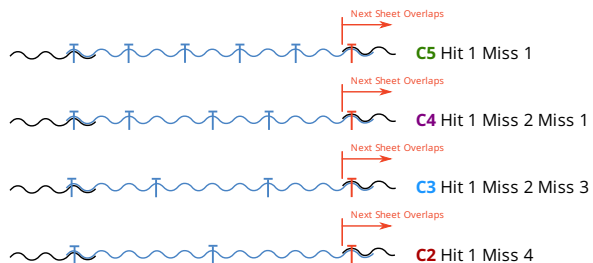

0.90 H36 Corrugated Aluminium (Min Depth 16.5 mm)

Access	Span (m)	Low	Med	High	Very High	Extra High
Unrestricted	0.6	C3	C3	C3	C3	C3
Restricted	0.9	C3	C3	C3	C3	C3
Restricted	1.2	C3	C3	C3	C3	C3

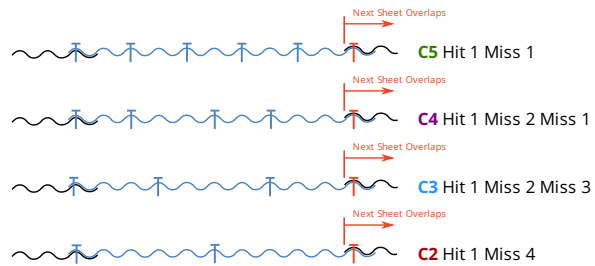

0.70 mm H36 Trapezoidal 5 Rib Aluminium (Min Depth 27 mm)

Access	Span (m)	Low	Med	High	Very High	Extra High
Restricted	0.6	5T2	5T2	5T2	5T2	5T2
Restricted	0.9	5T2	5T2	5T2	5T4	5T4

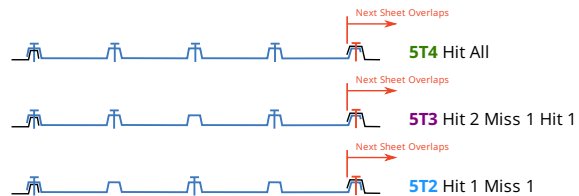

0.90 mm H36 Trapezoidal 5 Rib Aluminium (Min Depth 27 mm)

Access	Span (m)	Low	Med	High	Very High	Extra High
Unrestricted	0.6	5T2	5T2	5T2	5T2	5T2
Unrestricted	0.9	5T2	5T2	5T2	5T2	5T2
Unrestricted	1.2	5T2	5T2	5T2	5T2	5T2
Restricted	1.5	5T2	5T2	5T2	5T2	5T4

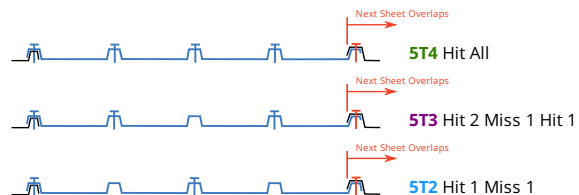

3.11 Wind Load/Span Graphs – Designs to AS/NZS1170

Wind Load span graphs should be read in conjunction with the constraint of access and the span at which the point load will be the limiting factor.

The performance of profiled metal cladding depends on the profile shape, thickness of the metal, the span, and the fastening type and pattern. These values can be greatly enhanced by using load-spreading washers or thicker material.

All the tests from which these graphs have been derived used the 2:3 ratio of end to intermediate span and the graphs shown are for intermediate spans only. End spans must be reduced by two-thirds for these values to be assumed.

3.11.1 Steel Cladding Wind Load Span Graphs

Wind Load span graphs should be read in conjunction with the constraint of access and the span at which the point load will be the limiting factor.

The performance of profiled metal cladding depends on the profile shape, thickness of the metal, the span, and the fastening type and pattern. These values can be greatly enhanced by using load spreading washers or thicker material.

All the tests from which these graphs have been derived used the 2:3 ratio of end to intermediate span and the graphs shown are for intermediate spans only. End spans must be reduced by two-thirds for these values to be assumed.

3.11.1.1 Corrugated Steel – 0.40

Standard Corrugate minimum 16.5 mm high, G550 Steel, 0.40mm BMT

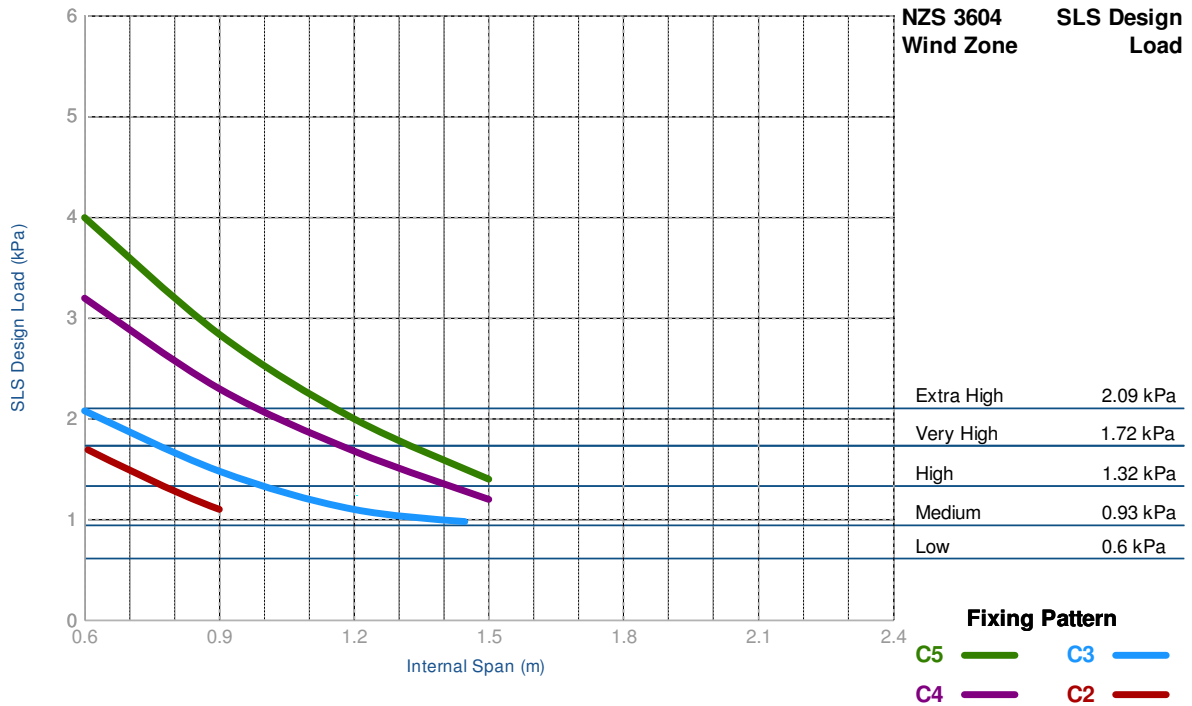

Recommended Point Load Limit		Span
Type A	Unrestricted Access	N/A
Type B	Restricted Access	0.9 m

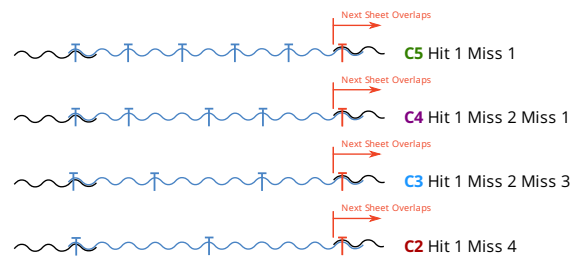

3.11.1.2 Corrugated Steel – 0.55

Standard Corrugate minimum 16.5 mm high, G550 Steel, 0.55mm BMT

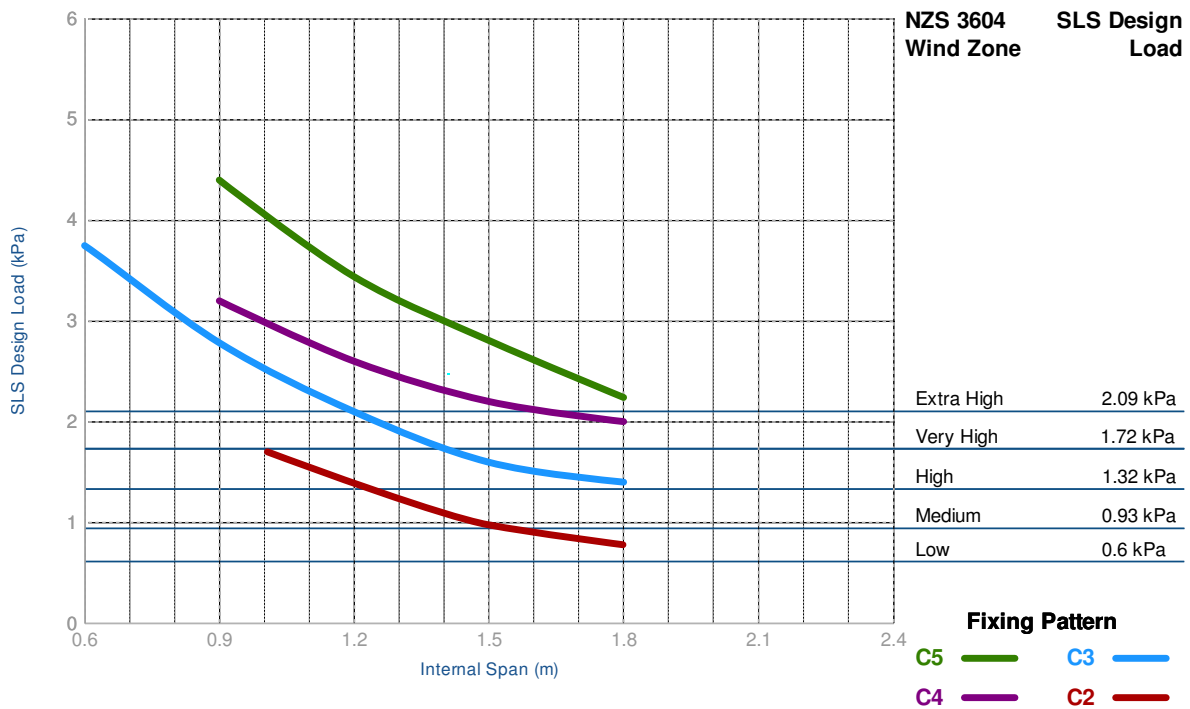

Recommended Point Load Limit		Span
Type A	Unrestricted Access	1.2 m
Type B	Restricted Access	1.5 m

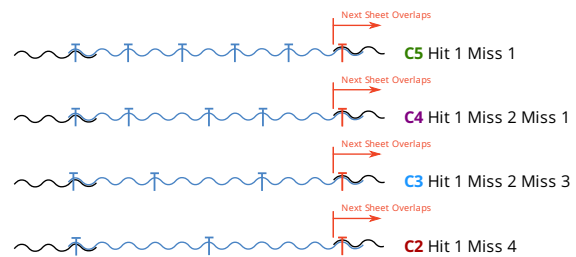

3.11.1.3

Trapezoidal Five Rib Steel – 0.40

Trapezoidal 5 Rib, minimum 27 mm high, G550 Steel, 0.40mm BMT

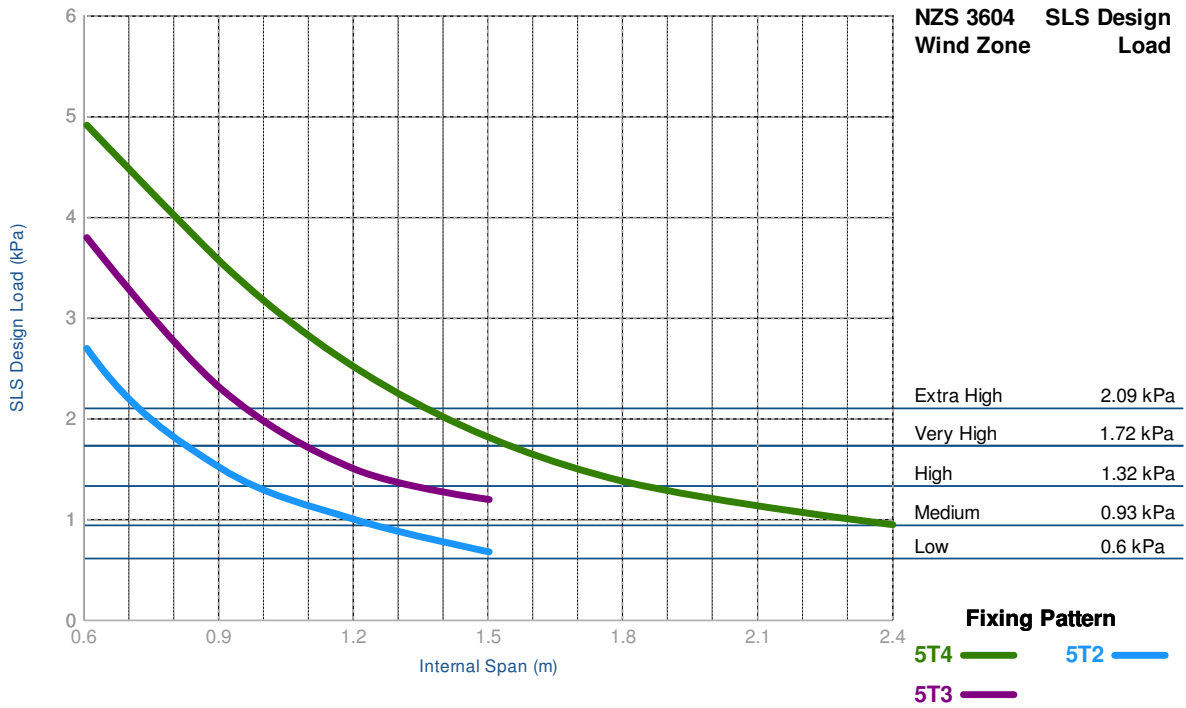

Recommended Point Load Limit		Span
Type A	Unrestricted Access	N/A
Type B	Restricted Access	1.4 m

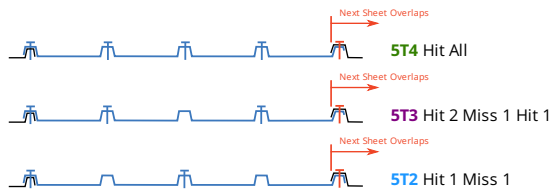

3.11.1.4 Trapezoidal Five Rib Steel – 0.55

Trapezoidal 5 Rib, minimum 27 mm high, G550 Steel, 0.55mm BMT

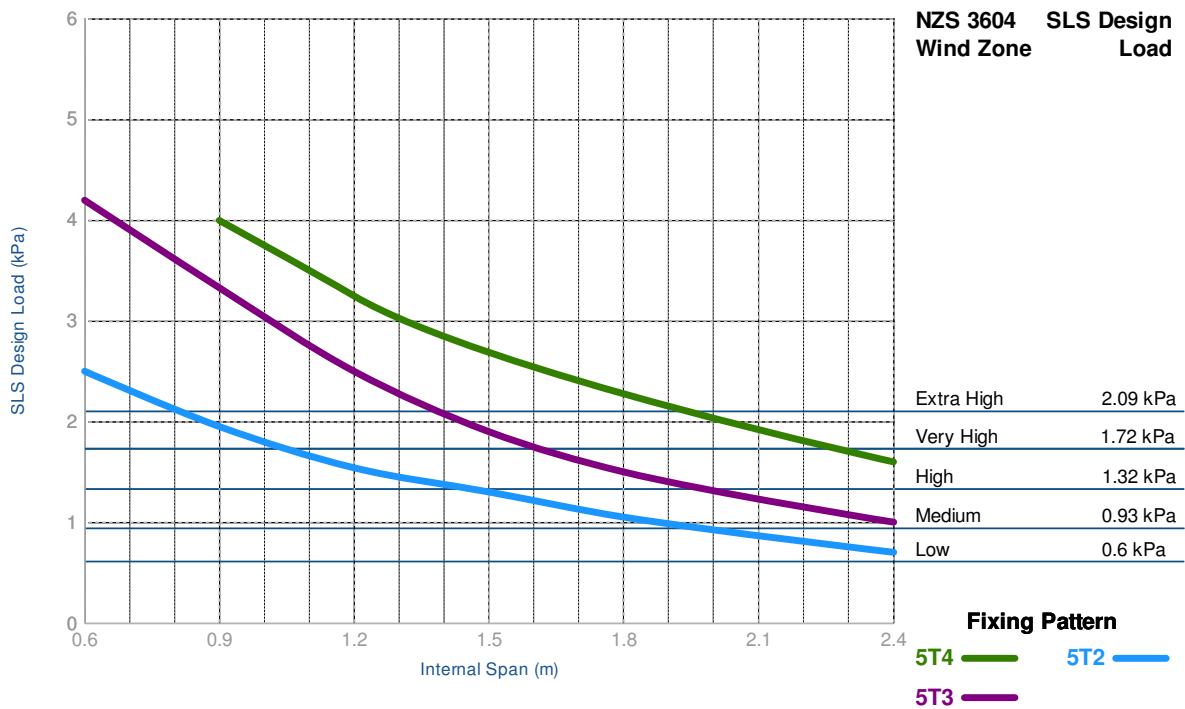

Recommended Point Load Limit	Span
Type A Unrestricted Access	1.5 m
Type B Restricted Access	2.1 m

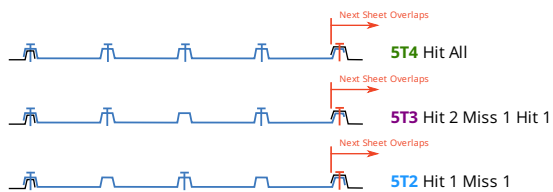

3.11.1.5 Trapezoidal Six Rib Steel – 0.40

Trapezoidal 6 Rib, minimum 27 mm high, G550 Steel, 0.40mm BMT

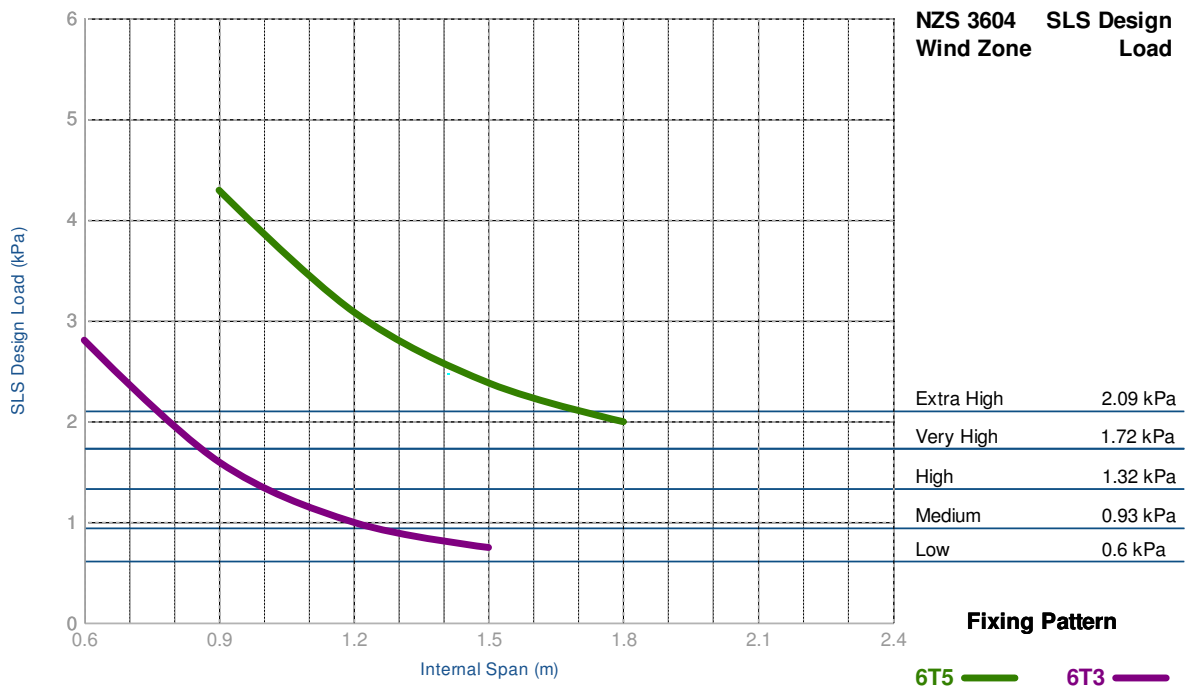

Recommended Point Load Limit		Span
Type A	Unrestricted Access	N/A
Type B	Restricted Access	1.5 m

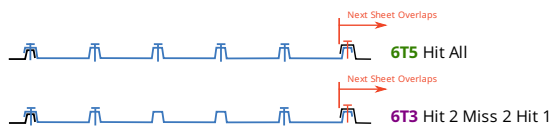

3.11.1.6 Trapezoidal Six Rib Steel – 0.55

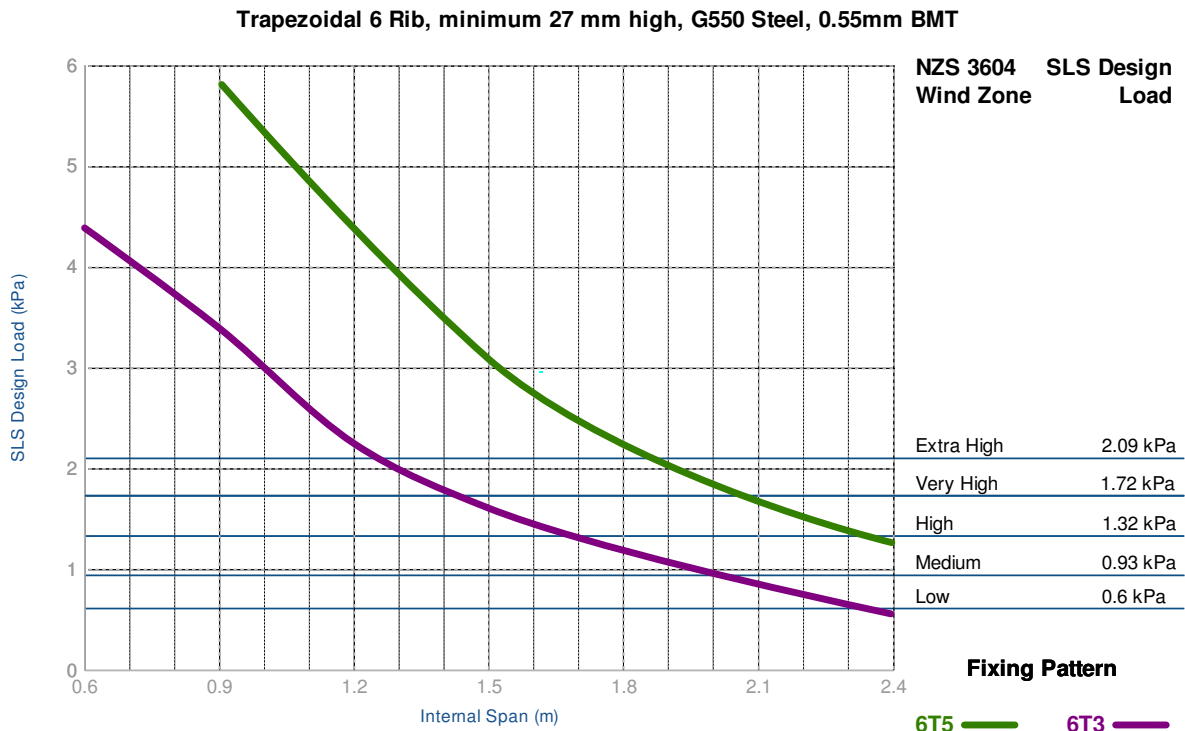

Recommended Point Load Limit	Span
Type A Unrestricted Access	1.5 m
Type B Restricted Access	2.2 m



3.11.2 Aluminium Cladding Wind Load Span Graphs

3.11.2.1 Corrugated Aluminium – 0.70

Standard Corrugate minimum 16.5 mm high, H36 5005/5025 Aluminium, 0.70mm BMT

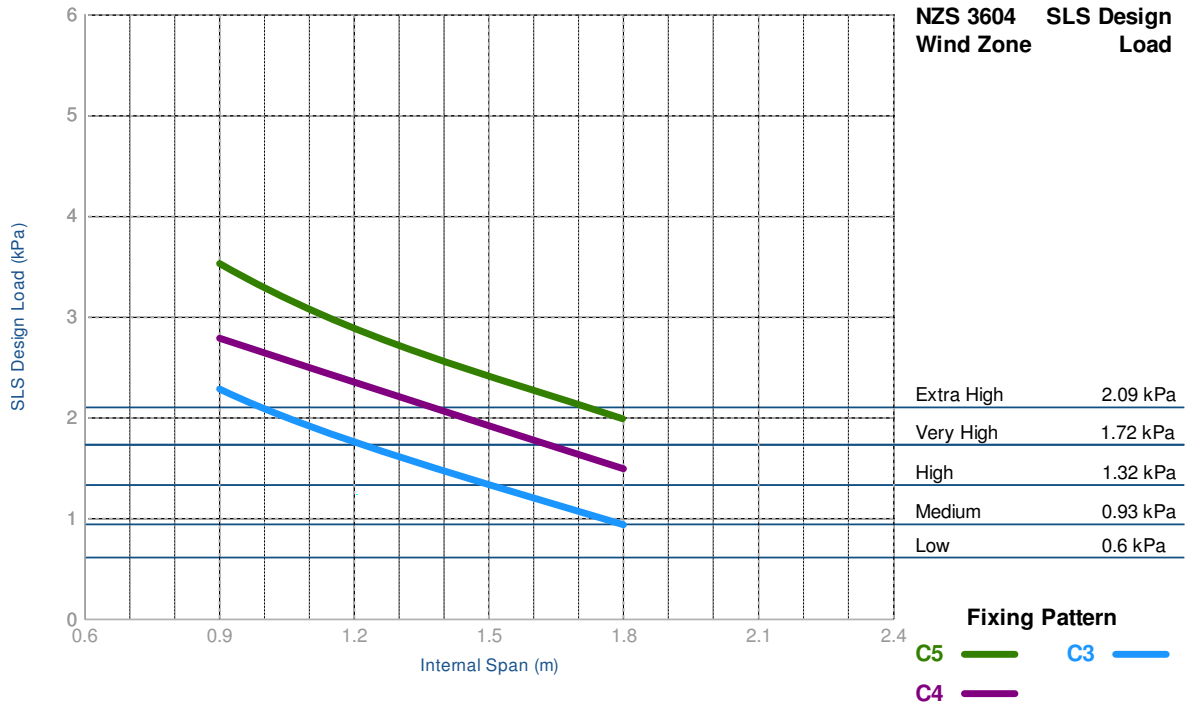

Please Note - Requires use of applicable Load Spreading Washers in all cases.

Recommended Point Load Limit	Span
Type A Unrestricted Access	N/A
Type B Restricted Access	0.8 m

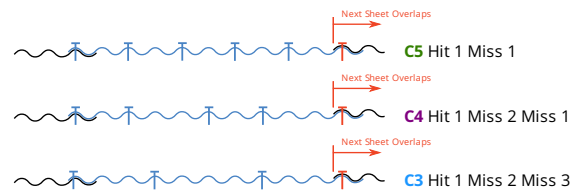

3.11.2.2 Corrugated Aluminium – 0.90

Standard Corrugate minimum 16.5 mm high, H36 5005/5025 Aluminium, 0.90mm BMT

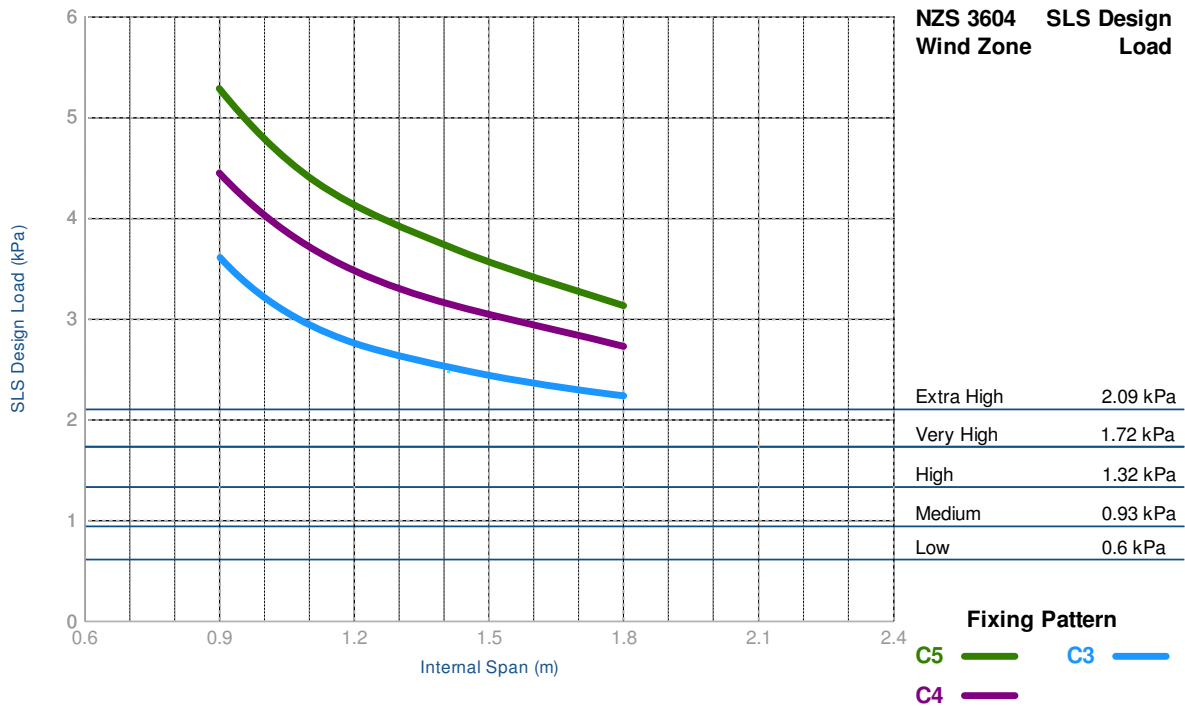

Please Note - Requires use of applicable Load Spreading Washers in all cases.

Recommended Point Load Limit	Span
Type A Unrestricted Access	0.8 m
Type B Restricted Access	1.2 m

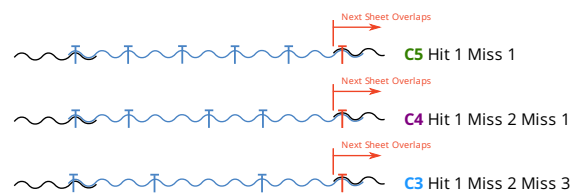

3.11.2.3 Trapezoidal Five Rib Aluminium – 0.70

Trapezoidal 5 Rib, minimum 27 mm high, H36 5005/5025 Aluminium, 0.70mm BMT

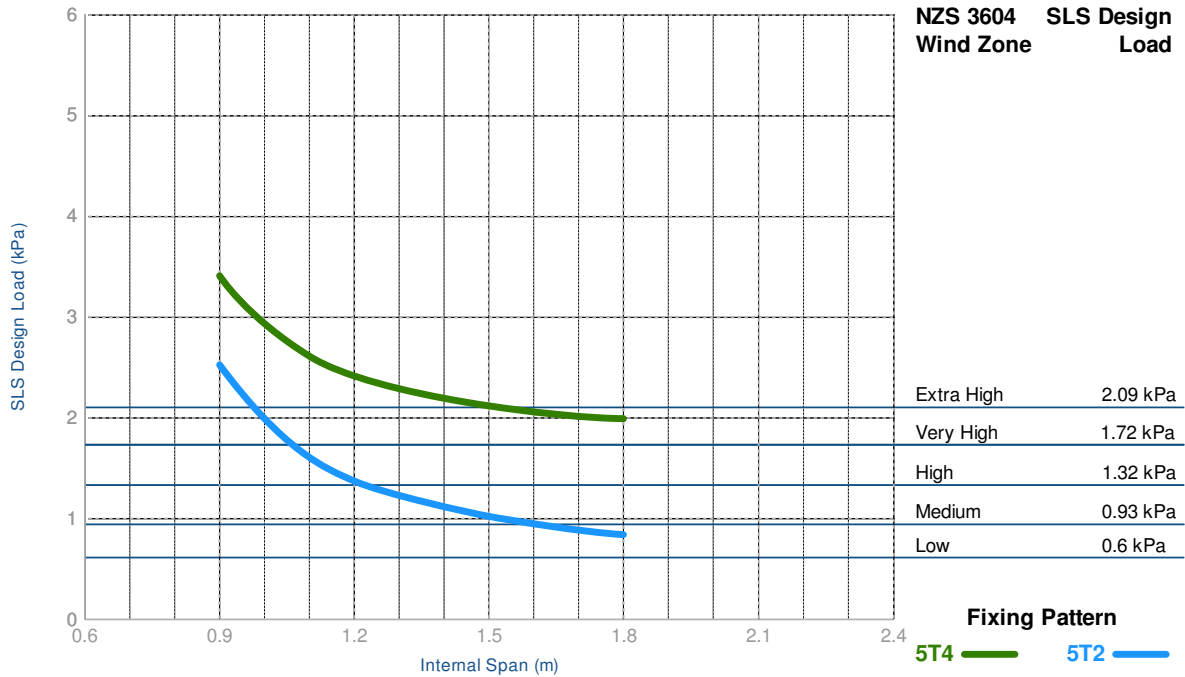

Please Note - Requires use of applicable Load Spreading Washers in all cases.

Recommended Point Load Limit		Span
Type A	Unrestricted Access	N/A
Type B	Restricted Access	1.2 m

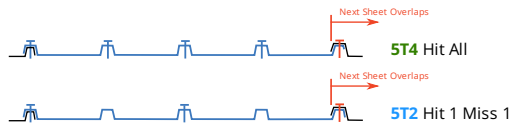

3.11.2.4 Trapezoidal Five Rib Aluminium – 0.90

Trapezoidal 5 Rib, minimum 27 mm high, H36 5005/5025 Aluminium, 0.90mm BMT

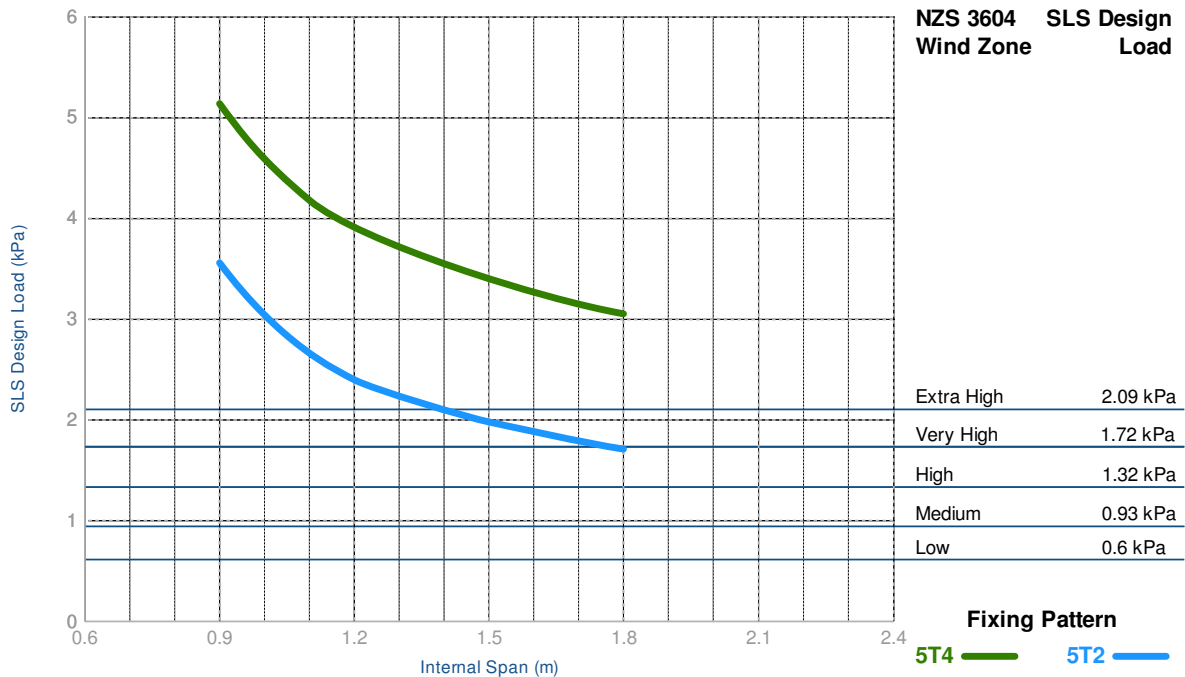

Please Note - Requires use of applicable Load Spreading Washers in all cases.

Recommended Point Load Limit	Span
Type A Unrestricted Access	1.2 m
Type B Restricted Access	1.7 m

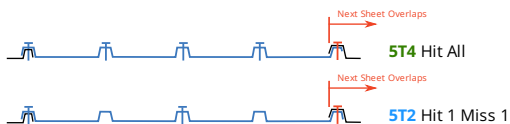

4

Durability

Corrosion (B2-Durability) covers considerations for continued performance of roof and wall cladding over the building lifecycle.

Key topics include:

- Material performance and coatings.
- Corrosion: environmental categories and special climates.
- Material compatibility – both "in contact with" and "runoff onto".
- Maintenance for prevention and remediation of corrosion.

4.1 NZBC Clause B2 (Extract)

Source: New Zealand Building Code, Clause B2 Durability

4.1.1 B2 Objective

The objective of this provision is to ensure that a building will continue to satisfy the other objectives of this code throughout its life.

4.1.2 B2 Functional Requirements

Building materials, components and construction methods shall be sufficiently durable to ensure that the building, without reconstruction or major renovation, satisfies the other functional requirements of the NZBC throughout the life of the building

4.1.3 Performance Requirements

Building elements must, with only normal maintenance, continue to satisfy the performance requirements of the NZBC for the lesser of the specified intended life of the building, if stated, or:

- a. *The life of the building, being not less than 50 years, if:*
 - *those building elements (including floors, walls, and fixings) provide structural stability to the building; or*
 - *those building elements are difficult to access or replace; or*
 - *failure of those building elements to comply with the building code would go undetected during both normal use and maintenance of the building.*
- b. *15 years if:*
 - *those building elements (including the building envelope, exposed plumbing in the subfloor space, and in-built chimneys and flues) are moderately difficult to access or replace; or*
 - *failure of those building elements to comply with the building code would go undetected during normal use of the building, but would be easily detected during normal maintenance.*
- c. *5 years if:*
 - *the building elements (including services, linings, renewable protective coatings, and fixtures) are easy to access and replace; and*
 - *failure of those building elements to comply with the building code would be easily detected during normal use of the building.*

Individual building elements which are components of a building system and are difficult to access or replace must either:

- *all have the same durability; or*
- *be installed in a manner that permits the replacement of building elements of lesser durability without removing building elements that have greater durability and are not specifically designed for removal and*

replacement.

4.1.3.1 Compliance

NZBC Clause B2, Durability, requires fifteen years to perforation for claddings easily accessed for replacement. Fifteen years is also required for internal gutters and downpipes, and five years for external gutters.

NZBC B2 requires 50 years' durability for flashings that require the removal of cladding above to be replaced, while table 20 of NZBC E2/AS1 only requires 15 years' durability for such flashings. The COP recommends the higher figure as good trade practice and in many cases, lower life-cycle costing.

Generally, higher durability than the minimum requirements can be achieved by using materials and methods outlined in this COP, with no maintenance of coatings other than washing areas which are not naturally washed by rain. Elements more difficult to replace, or to access for maintenance, should be constructed of more durable material.

Normal Maintenance means work recognised as being necessary to achieve the expected durability of a given building element.

According to B2/AS1, normal maintenance may include:

- Washing down surfaces subject to wind-driven salt spray and contaminants.
- Re-coating protective surfaces.
- Replacing sealant seals and gaskets in joints.

Although roof or wall cladding can be easily accessed and therefore easily replaced, the same cannot be assumed for flashings. Flashings might be embedded in plaster or behind other building elements, making them hard to replace without removing cladding or other building features such as windows.

Cladding material may be described as hidden, sheltered or exposed. Some flashings may have sections falling into all these categories, in which case the worst case (sheltered) should prevail in material selection.

All metal roof and wall cladding and accessories must be designed and installed to comply with the durability requirements of the NZBC. NZBC requirements relate to performance, however, and do not necessarily relate to aesthetics or cost of replacement. Any pre-painted cladding will change colour over time, and partial replacement would be visible. The roof cladding could have deteriorated, although not perforated, within 15 years and still comply with the NZBC, but customer expectations may not be met.

Good design, correct selection of materials, and good installation and maintenance practices are required to achieve optimum product lifespan.

4.2 Metal Corrosion

Corrosion is the process by which something erodes because of a chemical reaction.

Metal corrosion is a reaction of metal with its environment that causes measurable alteration and is part of metal's inherent tendency to revert to an original, more stable form. The red rusting of iron and steel is a visible example of corrosion and other examples include the weathering of copper and the oxidation of aluminium and zinc.

Corrosion can only happen in the presence of an electrolyte, e.g., water. The occurrence of salt (or other contaminants) in the water increases the conductivity of the electrolyte and therefore greatly increases the reaction rate.

Salt contamination will also affect the time of wetness. On a clean surface, water vapour will condense at 100% relative humidity, on a salt-covered surface, a wet film can be formed at a relative humidity level of 75% and more.

Corrosion can also be the result of direct contact with another metal or substance, or the result of run-off from incompatible surfaces or fall-out of corrosive particles. Time of wetness, presence or lack of oxygen, and atmospheric contaminants greatly affect the rate of corrosion.

Differences in electrical potential on the surface of corroding metal create microscopic cells comprising cathodes and anodes. In the case of iron, the positively charged electrons in the anode react with the negatively charged hydroxyl ions in the electrolyte to form iron oxide on the anode. Similar reactions occur with other metals. Polarisation changes on the surface cause anodic areas to become cathodic and vice versa, so that over time the rate of corrosion is relatively uniform over the surface.

The build-up of debris on a cladding surface will promote corrosion. The salts in the debris react with the cladding each time they are wetted, and the deposits themselves impede surface-drying, increasing the time of wetness.

4.3 Metal Performance

To understand metal performance in any specific environment, the unique properties of each metal should be considered in conjunction with other metals it is used with.

All metals react differently to the atmosphere and to any contaminants that come into contact with their surface by rain, wind or condensation. The indicator of acidity or alkalinity is pH, measured from 0 – 14; acidity/alkalinity is an important corrosion factor. pH 7 is neutral, below 7 is more acidic, above 7 is more alkaline.

4.3A Metal Performance in Acid/Alkaline Environments

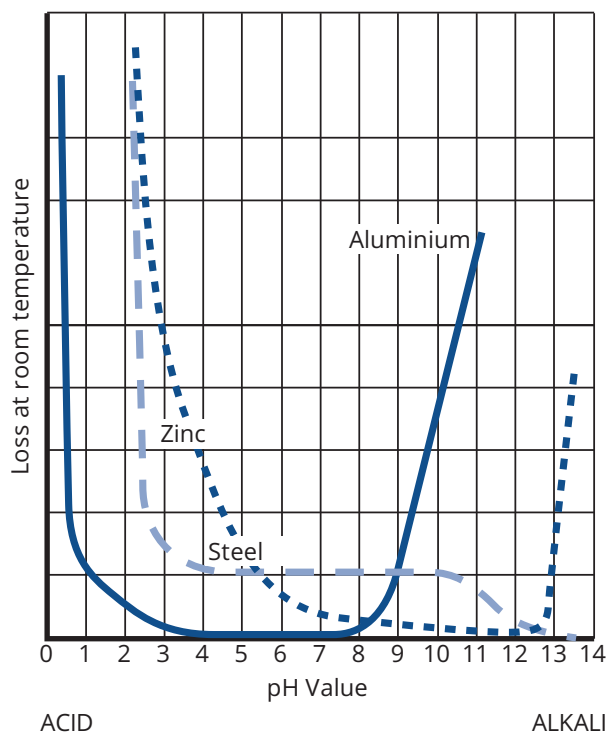

As can be seen from the graph above, zinc performs better in alkaline environments, and aluminium performs better in acidic environments.

Aluminium-zinc coatings should be avoided in buildings such as closed animal shelters or fertiliser storage sheds, where alkalinity may be high.

4.4 Sacrificial and Barrier Protection

The zinc and aluminium families of metallic coatings protect the steel base from corrosion in two different ways:

- Zinc predominant coatings protect the substrate primarily by offering sacrificial protection.
- Aluminium predominant coatings primarily offer barrier protection.

4.4.1 Sacrificial Protection

Zinc is more electrically active than steel. By coating steel with zinc, or a zinc-rich product, the zinc becomes the anode for the steel. The steel then becomes the cathode and does not react with the electrolyte. The process is known as cathodic protection.

This protective effect occurs even when there is a small area of steel exposed directly to the electrolyte, such as a cut sheet edge, drill hole or scratch.

While the zinc reacts in preference to the steel, it does so at a slower rate. In normal environmental conditions, the zinc-oxide layer that initially forms on the surface of the zinc combines with carbon dioxide in the atmosphere to form zinc carbonate. That creates a sealed layer with excellent adhesion, and as zinc carbonate has very low solubility, reaction with the electrolyte slows even more.

4.4.2 Barrier Protection

Barrier protection works primarily by providing a physical barrier between the atmosphere and the steel substrate.

The surface of aluminium-dominant coatings is initially very active, but it quickly forms an inert aluminium-oxide film when exposed to normal atmospheric conditions. Aluminium dominant coatings on steel mainly provide barrier protection as the aluminium, having formed an oxide surface, ceases to offer substantial sacrificial protection.

The exposed edges of barrier protected cladding should not be in contact with corrosive surfaces. See [4.9.4 Compatibility Table](#)

4.5 The Environment

4.5.1 Atmosphere

The durability performance of metal roof and wall cladding depends on the macro- and microclimates, airborne contaminants, and the material itself.

The macroclimate is the general environmental category where the building is situated.

The microclimate relates to the exact location of the building and the design or position on the roof or wall. Microclimate influences include geothermal fumaroles, rain sheltering, topography and ground roughness, prolonged wetness, and exclusion of oxygen. Internal microclimates can also occur as result of the particular use of the building.

Contaminants and pollutants are corrosive influences which can affect the cladding. These can include fertiliser, soil, leaf fall-out, exhaust fumes, industrial fumes, bird droppings and the build-up of debris. Influences such as chlorides near the sea, geothermal hydrogen sulphide (H₂S) or man-made gases such as sulphur dioxide (SO₂) accelerate the corrosion rate by increasing the conductivity of the electrolyte and changing its pH value.

Rain provides the moisture that acts as the electrolyte in corrosion cells. Rain varies in pH because it picks up various contaminants from the pollutants in the atmosphere. Acid rain can happen in geothermal areas due to the presence of hydrogen sulphide in the atmosphere.

At 0°C metal corrosion is minimal, because colder temperatures slow the reaction. The corrosion rate of some metals doubles with every 10°C rise in temperature given the same time of wetness and environmental conditions. However, in dry, warm environments the time of wetness is decreased by faster drying times, which has the opposite effect.

Designers should be aware of macro- and microclimates and the degree of contamination. They should design their building and select materials considering a combination of all these factors.

4.5.2 Sea Spray

The major contributor to metal corrosion in New Zealand is sea spray. Sea spray contains a mixture of salts consisting of 2.5 to 4% sodium chloride and small quantities of magnesium, calcium and potassium chloride. These salts make water far more electrically conductive.

Sea spray, evaporation, and infrequent rain increase salt concentrations on exterior surfaces, particularly when it accumulates in unwashed areas.

4.5.2A Airborne Salt from Sea Spray.



Onshore winds, big swells, wide generation zone and rugged coastline make ideal conditions for the production of salt aerosol.

The distance airborne salt is carried inland varies significantly with local wind patterns. Salt deposits have been measured as far inland as Lake Taupo in the North Island. Geographic or man-made obstructions, such as trees or buildings, slow air velocity and allow the air to discharge some of its salt burden, which can make the environment less aggressive. Conversely, where there are few impediments to the free flow of air, severe marine influence can extend well inland.

In high humidity levels, or when wetted by condensation, marine salts absorb water and form a chloride solution. Therefore, the effect of salt spray is greatest in unwashed areas, where salts can accumulate over time.

Where the ends of roof cladding are exposed to contaminants such as sea salt or industrial pollutants, it is good practice to provide an over flashing which discharges into the gutter or spouting. (See [8.5.4.4A Gutter-Eaves Flashing](#).)

- It gives a measure of protection to the underside of the roof cladding and the underlay.
- It provides support for the roofing underlay which is subject to damage from wind and UV.
- When using PVC spouting, there is a gap between the spouting and the fascia caused by the thickness of the brackets. In coastal locations where the ends of roof cladding are exposed, this unwashed area becomes susceptible to corrosion. A gutter apron can minimise this risk.
- If there is no spouting or it has a low front.
- In severe environments, wind can drive contaminants up the ribs of exposed ends of roof cladding. Metal scriber flashings or filler blocks can be used to prevent or inhibit ventilation.

The over flashing should extend 50 mm into the gutter, and the underlay finishes on the down-slope of the flashing. If there is no over-flashing to the gutter, the underlay should be extended into the gutter by a minimum of 20 mm.

In some cases, the over flashing becomes a sacrificial flashing which can extend the life of the cladding. In such circumstances, the COP recommends making the flashing from aluminium.

4.6 Environmental Categories

Suppliers of pre-painted metal offer alternative products for different environments, using different metallic coatings, paint systems, paint thickness and metals. The designer or the roof cladding contractor should carefully assess and evaluate these options to comply with the NZBC.

The boundaries of different corrosion zones are difficult to define because many factors determine the corrosivity of a particular location. The designer should choose the appropriate materials for the location, which meet the minimum durability requirements of the NZBC and satisfy customer expectations.

4.6.1 Assessment of Marine Environments

Wind is responsible for the salinity present in marine atmospheres. The wind picks up particles of salt from breaking waves and can carry them inland. The quantity of salt aerosol entrained by the wind is affected by many factors, such as wind strength, wave height, the width of the generation zone, and the contours of the seabed and coastline. These factors along with the persistence of the wind from a given quarter determine the corrosivity of a shoreline.

While salt deposits are measurably present in inland areas such as Taupo, the main effect of marine atmospheres reaches just a few hundred metres from the shore. Particles of salt in the air deposit on adjacent surfaces through gravity and contact; the rate at which deposits settle is affected by the roughness of the ground that the salt-laden air passes over. Obstacles such as trees slow the wind down, increasing the rate of gravitational deposit, and bringing the salt aerosol in more contact with surfaces on which they can deposit.

On the other hand, open flat land and natural “wind tunnels” can allow quite high concentrations of salt to travel several hundred metres inland.

A site’s location, relative to the sea or marine inlets, is a common method used to assess the corrosivity of a location. The distance from salt water for a given Zone varies with the location, depending on the prevailing winds and roughness of water in those areas, as well as the evenness of the terrain it passes over.

Where environmental Zones overlap, a site-specific evaluation may help define the category into which it best fits. Visual evidence of corrosion on adjacent metal surfaces may be present, ground roughness can be assessed, industrial influences can be evaluated and data about the persistence of onshore winds can be obtained from NIWA.

More local factors that affect the corrosivity of a specific location include:

- Overhanging shade increases the time of wetness of a structure and corrosion rate.
- High levels of water roughness such as caused by strong tidal flow against the wind direction, as is often experienced in areas such as Cook Strait, increases salt spray.
- Surfaces not receiving regular and effective rain washing or sufficient manual washing may experience corrosion rates two to three times that of cleaned surfaces.

There are many ways of more accurately determining the actual corrosivity of a given location. The most commonly accepted method as outlined in ISO 9223 is measuring first-year corrosion rate of different metals: mild steel (MS), zinc, aluminium and copper. The COP uses the first-year corrosion rate of mild steel as the most relevant and reliable indicator of a location's corrosivity.

The names given by different Standards for given corrosion zones vary. The Corrosion Zones in the Code of Practice are similar to those published in NZS 3604:2011 except that:

- the COP makes a distinction between Harbours, West Coast, and East Coast shorelines, and
- NZS 3604 Zone D (High) is further broken down into E (Very High) and F (Extreme Marine) because, in NZS 3604 Zone D, the first-year mild steel corrosion rate can vary from 200 g/m² to 1000 g/m².

4.6.1A Corrosion Zone Categorisation and First year Mild Steel Corrosion Rate (g/m²)

NZS3604	Code of Practice	Description	MS Corrosion Rate (g/m ²)
B	A (Mild)	Far inland, with no industrial pollution or thermal activity, or dry internal. This condition is not commonly found externally in New Zealand.	1 – 10
	B (Moderate Inland)	Most dry rural areas in New Zealand, 50 km from the coast, are in this category. It can extend closer to the coastline of sheltered water in low rainfall areas.	10 – 80
C	C (Moderate Marine)	This category covers area of low marine influence. It can extend from 50 km inland to within 1 – 1.5 km of west coast beaches, or be in the immediate vicinity of calm estuaries.	80 – 200
D	D (Severe Marine)	In this category, marine influences are frequently apparent. Its proximity to the coast is determined by the roughness of the water, prevailing winds, ground roughness and sheltering.	200 – 400
	E (Very Severe Marine)	In this category, the structure is normally exposed and marine influences are almost constantly apparent.	400 – 650
	F (Extreme Marine)	This category is rare in a building site. It would be an exposed location very close to breaking surf.	650 – 1000

4.6.2 Environmental Guides

The following tables provide guidance for specific regions and environments. See [4.6.1A Corrosion Zone Categorisation and First year Mild Steel Corrosion Rate \(g/m²\)](#) for descriptions of specific categories.

4.6.2A West Coast and South Coast: Both Islands

Zone	Distance from the Shoreline
B Moderate Inland	55 km
C Moderate Marine	1,000 m (1 km) 60 km
D Severe Marine	200 m 1,200 m (1.2 km)
E Very Severe Marine	100 m 300 m
F Extreme Marine	150 m

4.6.2B East Coast (Including West facing shores of large harbours)

Zone	Distance from the Shoreline
B Moderate Inland	50 km
C Moderate Marine	500 m 55 km
D Severe Marine	100 m 600 m
E very Severe Marine	50 m 200 m
F Extreme Marine	75 m

4.6.2C Harbours

Zone	Distance from the Shoreline
B Moderate Inland	45 km
C Moderate Marine	200 m 50 km
D Severe Marine	500 m
E very Severe Marine	50 m

4.6.2D Estuaries (Calm Inlets)

Zone	Distance from the Shoreline
B Moderate Inland	45 km
C Moderate Marine	50 km
D Severe Marine	50 m

4.6.3 Material Selection

Note: this is the minimal requirement to achieve compliance with NZBC Clause B2-Durability. Meeting the minimum requirements of NZBC clause B2 Durability does not necessarily represent optimal product selection. In a transition zone, it may be more cost effective over the life cycle of the building, and for meeting customer expectations, to choose a more durable option.

4.6.3A Material Selection : Exposed Roofs and flashing

Durability Required : 15 years

Marine Zone	Exposed Fastener Class (minimum)	Acceptable Materials
***As defined by AS/NZS 2728.		
B: Moderate Inland	C4	Aluminium
		Pre-painted aluminium
		Pre-painted steel Type 6***
		Pre-painted steel Type 4***
		AZ 150 coated steel
C: Moderate Marine	C4	Aluminium
		Pre-painted aluminium
		Pre-painted steel Type 6***
		Pre-painted steel Type 4***
		AZ 150 coated steel
D: Severe Marine	C4	Aluminium
		Pre-painted aluminium
		Pre-painted steel Type 6***
		Pre-painted steel Type 4***
E: Very Severe Marine	C5	Aluminium
		Pre-painted aluminium
		Pre-painted steel Type 6***
F: Extreme Marine	C6	Aluminium
		Pre-painted aluminium

Materials accepted by NZMRM as complying with coating types include:

- Painted steel Type 4:
Colorsteel® Endura®, Colorcote® ZinaCore™
- Painted steel Type 6:
Colorsteel® Maxx®, Colorcote® MagnaFlow™, Colorcote® MagnaFlow X™

4.6.3B Material Selection : Walls*, fascias and sheltered roofs and flashings

Durability Required : 15 years

Marine Zone	Exposed Fastener Class (minimum)	Acceptable Materials
*The practicality of carrying out regular maintenance, and difficulty of replacement, should also be considered when considering wall cladding material options.		
***As defined by AS/NZS 2728.		
B: Moderate Inland	C4	Aluminium
		Pre-painted aluminium
		Pre-painted steel Type 6***
		Pre-painted steel Type 4***
		AZ 150 coated steel
C: Moderate Marine	C4	Aluminium
		Pre-painted aluminium
		Pre-painted steel Type 6***
		Pre-painted steel Type 4***
		AZ 150 coated steel
D: Severe Marine	C4	Aluminium
		Pre-painted aluminium
		Pre-painted steel Type 6***
E: Very Severe Marine	C5	Aluminium
		Pre-painted aluminium
		Pre-painted steel Type 6***
F: Extreme Marine	C6	Aluminium
		Pre-painted aluminium

Materials accepted by NZMRM as complying with coating types include:

- Painted steel Type 4:
Colorsteel® Endura®, Colorcote® ZinaCore™
- Painted steel Type 6:
Colorsteel® Maxx®, Colorcote® MagnaFlow™, Colorcote® MagnaFlow X™

4.6.3C Material Selection : Flashings Behind Cladding

Durability Required : 50 years

Marine Zone	Acceptable Materials
**Stainless steel must not be in wet contact with metallic coated steel, plain or painted.	
***As defined by AS/NZS 2728.	
B: Moderate Inland	Stainless Steel**
	Aluminium
	Pre-painted aluminium
	Pre-painted steel Type 6***
	Pre-painted steel Type 4***
	AZ 150 coated steel Galvanised steel Z 450
C: Moderate Marine	Stainless steel**
	Aluminium
	Pre-painted aluminium Pre-painted steel Type 6***
D: Severe Marine	Stainless steel**
	Aluminium
	Pre-painted aluminium
E: Very Severe Marine	Stainless steel**
	Aluminium
	Pre-painted aluminium
F: Extreme Marine	Stainless steel**
	Aluminium
	Pre-painted aluminium

Materials accepted by NZMRM as complying with coating types include:

- Painted steel Type 4:
Colorsteel® Endura®, Colorcote® ZinaCore™
- Painted steel Type 6:
Colorsteel® Maxx®, Colorcote® MagnaFlow™, Colorcote® MagnaFlow X™

4.7 Special Climates

In areas where humidity or local conditions create an increased likelihood of corrosion, special consideration should be given to the specification and use of metal roof and wall cladding and accessories.

4.7.1 West Coast, South Island, South Coast, North Island

The West Coast is characterised by high rainfall and a very severe coastal environment between the sea and the Southern Alps; many households have coal burning fires that produce sulphur dioxide that is detrimental to metals. The combination of these factors means that either a shorter performance life should be accepted or the use of more durable metals and coatings considered.

The North Island's south coast not only has strong onshore prevailing winds, but strong current flows increase wave action and the amount of salt-laden air, creating a particularly harsh marine environment.

4.7.2 Geothermal

Buildings within 50 m of a geothermal fumarole are considered to have a geothermal microclimate, which causes increased corrosion due to higher humidity levels combined with hydrogen sulphide.

Highly active geothermal areas, such as much of Rotorua, are considered geothermal, even in the absence of a local fumarole.

4.7.3 Internal Environments

Corrosive internal environments with high humidity, causing condensation, and pollutants generated within the building can also affect neighbouring buildings. These include:

- covered swimming pools;
- fertiliser works;
- meat works;
- animal sheds or shelters;
- pulp and paper manufacturing; and
- vehicle exhaust fumes.

4.7.4 Fossil Fuel Residue

Sulphur dioxide develops when burning fossil fuels. After oxidation and reaction with water it forms sulphuric acid (H_2SO_4) that can contribute considerably to the atmospheric corrosion of zinc and steel.

Burning resinous woods, CCA-treated timber, low-grade coal or oils with a high sulphur content can increase the fall-out deposit or condensate from flue gas.

Exhaust fans can cause similar problems when corrosive gases are not filtered at their source.

4.8 Paint Durability

New Zealand has a harsh level of ultraviolet light. Paint formulations that are successful overseas have sometimes been found lacking colour fastness in the Australasian environment. Proprietary pre-painted cladding products should give durability protection and keep its appearance for at least 15 years, and at the end of that period still have the anti-corrosive primers intact and present a good substrate for over-painting.

The performance of all paint coatings, however, can be affected by avoidable outside influences.

4.8.1 Touch-up Paint

Colour match paint is sold in pre-colour matching accessories, such as soft edging or brackets, to match the pre-painted cladding. It should only be pre-applied before installation and should not be used to repair minor scratches and blemishes. These paints may closely match the pre-painted surface initially, but being an air drying acrylic, it is likely to weather differently to the pre-applied coating and cause unsightly blotches.

4.8.1A Touch-up Paint Weathering



4.8.2 Sunscreen Lotions

Sun screen lotions containing semi conducting metal oxides, such as titanium dioxide and zinc oxide, will cause discoloration of painted surfaces over time. There is no cure for such damage so contact of such chemicals with pre-painted cladding must be avoided.

4.8.2A Sunscreen Lotion Marks



4.8.3 Graffiti Removal

Most Graffiti removal processes involve the use of strong solvents, abrasion, or extreme temperatures. It is generally difficult to remove graffiti without compromising an existing organic finish; the normal remedy is to overpaint as soon as possible. On a weathered pre-painted finish this can generally be achieved by washing and rinsing the surface to remove dirt and other contaminants, then applying two coats of acrylic paint.

It should be noted that such overpaint cannot over time, be expected to match the appearance of existing pre-applied finishes.

4.8.4 Lichen

Warm temperatures, dust, and rainfall can create an environment for lichens to flourish. Over time the root structures of lichen may infiltrate a painted surface and cause permanent damage.

Lichen growths retain moisture and, therefore, increase the time of wetness. They are fed by nutrients in the

atmosphere and tend to occur more commonly in moist and unpolluted environments. Where lichen growth is present, it should be removed. See [16 Maintenance](#) .

Physical removal is difficult to achieve completely, and recolonisation is usually rapid. Chemical treatment is recommended. New Zealand Steel publishes a formula for batching a 2% sodium Hypochlorite solution to be used for this.

4.8.4A Lichen on a Metal Roof



4.8.4B Permanent Damage from Lichen Growth



Lichen growth can cause permanent damage if not treated promptly

4.9 Compatibility

Materials comprising the building envelope should not be considered in isolation, as their performance can be affected by contact with or run-off from other materials.

This reaction is caused by either their relative places in the electro-chemical series or by the mineral composition of their surface moisture.

4.9.1 Dissimilar Metals

A component which may appear suitable may prove unsatisfactory in service because it is incompatible with another material or substance in contact with it.

This incompatibility can occur when the metals are in electrolytic contact or when water from one metallic surface discharges onto another. When a noble metal dissolves in water and flows over a less noble one, the more noble metal deposits on the less noble metal and create corrosion conditions.

4.9.1A Galvanic Series

Galvanic Series	
Magnesium	Active (Anode)
Zinc	▲
Galvanised Steel	
Aluminium	
Mild Steel	
Cast Iron	
Lead	
Brass	
Copper	
Bronze	
Monel	
Nickel (passive)	
Stainless Steel 304 (passive)	
Stainless Steel 316 (passive)	
Silver	
Titanium	
Gold	
Graphite	
Platinum	Noble (Cathode)

The similarity of metals is indicated by their relative position in the galvanic series. The more dissimilar the metals, the greater the corrosion potential in a galvanic circuit

Generally, run-off from metals higher on the table to those lower will not cause corrosion, but run-off in the other direction may do so.

Metals such as aluminium, stainless steel, and Zinalume® form an inert surface that does not produce soluble salts and run-off from them will not result in dissimilar metal corrosion. However, because these surfaces are inert, potential for run-off to create inert catchment corrosion on unpainted zinc or galvanised steel must be considered.

4.9.1B Lead in Contact with AZ



Lead in contact with coated or uncoated AZ will cause premature corrosion.

4.9.1C Cladding in Contact with Stainless Steel Rivet



Stainless rivets will cause corrosion to Z AZ and ZA coated products.

Where the use of dissimilar metals is unavoidable, a non-absorbent inert material can be used as an electrolytic separator. Long-term corrosion resistance depends on the separation remaining effective.

Examples of separation materials are inert plastic tapes, polythene or silicone sealant, and in the case of fasteners an EPDM sealing washer.

Where gutters and spouting are made from materials incompatible with roof the cladding, there can be contamination from immersion of the sheet ends if the gutter is poorly drained. Special provisions, such as ensuring there is a 10 mm drainage gap between spouting and fascia should be made to avoid immersion of coated steel roofing into copper gutters. Discharging the gutter into a rain head with leaf deflector can also help. Low front spouting can be considered, but that creates aesthetic issues and may contribute to early corrosion in marine areas. No part of copper gutters should be in contact with coated steel roofing or flashings.

4.9.2 The Electrochemical or Galvanic Series

The electrochemical tables or galvanic series scales, often quoted in technical literature as a measure of corrosion, show the electro-potential between pure metals, not between their oxides, carbonates or chlorides.

Although theoretically correct, these tables can give a misleading indication of the performance of different materials in contact.

This series only applies to pure metal. Under certain conditions, some metals react with the environment or chemicals to form a passive surface, which renders them less active, so that any ranking can be misleading. "Passivity" becomes an important phenomenon in controlling corrosion rates.

However, the Electrochemical series table is still a useful indicator of electrode potential. The further apart two metals are in the electrochemical series, the greater the potential difference between them.

Metals termed anodic, active, negative, or less noble corrode in preference to metals that are deemed more cathodic, noble, positive or less active. The less noble metal becomes the anode and is subject to corrosion. The greater the potential difference, the more corrosion there will be of the less noble metal; i.e., on the anode.

The difference in nobility is why zinc can protect a steel substrate.

Different electrolytes can lead to different rankings, and metal alloys may display more than one potential than that which applies to their "active" state.

The exposed surface ratio of anode and cathode determines the rate of dissimilar metal corrosion. For instance, if a fastener which has a small surface compared to the cladding becomes the anode, its current density will be high, and the fastener will corrode quickly; e.g., an aluminium rivet in a copper sheet. When the opposite is the case, the effect is not so great.

The [4.9.2A Electrochemical table](#) shows zinc is more active than steel. Contact between steel and zinc, in the presence of moisture, will cause the zinc to corrode or sacrifice itself, to protect the steel.

4.9.2A Electrochemical table

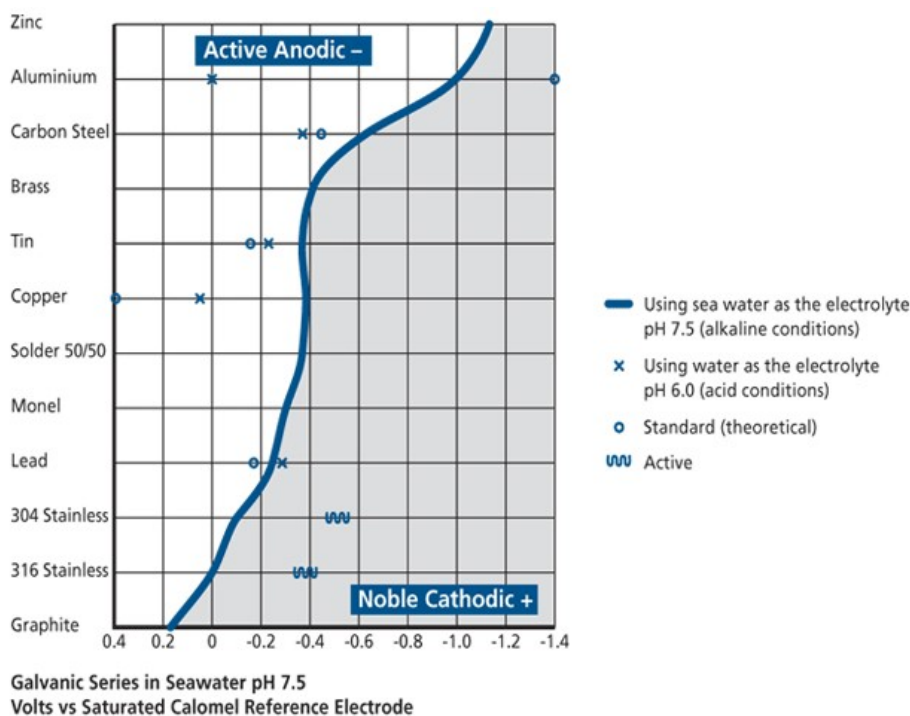

4.9.3

Compatibility with Non-Metallic Substances

Timber is generally acidic, although some timbers—such as cedar—are more acidic than others. The interaction between preservative treated timber and metal depends on the moisture content of the timber, the time of wetness and the type of treatment. The corrosion rates of metal in contact with wet CCA-treated timber and with untreated radiata are similar.

Neither AZ coated steel nor aluminium should be used as a flashing embedded in concrete or masonry.

4.9.3A Butyl Rubber in Wet Contact with Cladding



Butyl rubber in wet contact with coated aluminium and steel has been found to accelerate corrosion.

4.9.4

Compatibility Table

The compatibility table should be regarded as indicative only, due to the many permutations of the environment, the amount of moisture present and the relative size of the components.

The indicator for “use with caution in moderate environments” should be interpreted as a warning that it could be unsuitable when there is a risk of continued moisture or other contaminants.

4.9.4A Interactive Material Compatibility Tool

The Code of Practice Online provides an interactive tool to interpretation of the information in the [4.9.4B Material Compatibility Table](#) Table, by simply selecting the two materials in use to view compatibility. This tool is only available online at

www.metalroofing.org.nz/cop/durability/compatibility#compatibility-table...

4.9.4B Material Compatibility Table

Material water flows from		Aluminium	prepainted aluminium	AZ Coated Steel	zinc	Galvanised steel	Painted Galvanised Steel	Pre-Painted Steel	Copper/brass	Stainless steel	Lead	Plastic/glass	concrete/plaster	Wet timber	Cedar	Butyl rubber
Aluminium	Contact	Y	Y	Y	Y	Y	Y	Y	N	C	N	Y	N	N	N	C
	Run onto	Y	Y	Y	N	N	Y	Y	Y	Y	Y	Y	Y	Y	Y	Y
prepainted aluminium	Contact	Y	Y	Y	Y	Y	Y	Y	N	N	N	Y	N	N	N	N
	Run onto	Y	Y	Y	N	N	Y	Y	Y	Y	Y	Y	Y	Y	Y	Y
AZ Coated Steel	Contact	Y	Y	Y	Y	Y	Y	Y	N	N	N	Y	N	N	N	N
	Run onto	Y	Y	Y	N	N	Y	Y	Y	Y	Y	Y	Y	Y	Y	Y
Zinc	Contact	Y	Y	Y	Y	Y	Y	Y	N	C	Y	Y	C	N	N	N
	Run onto	Y	Y	Y	Y	Y	Y	Y	Y	Y	Y	Y	Y	Y	Y	Y
Galvanised steel	Contact	Y	Y	Y	Y	Y	Y	Y	N	C	Y	Y	Y	N	N	N
	Run onto	Y	Y	Y	Y	Y	Y	Y	Y	Y	Y	Y	Y	Y	Y	Y
Painted Galvanised Steel	Contact	Y	Y	Y	Y	Y	Y	Y	N	N	N	Y	N	N	N	N
	Run onto	Y	Y	Y	N	N	Y	Y	Y	Y	Y	Y	Y	Y	Y	Y
Pre-Painted Steel	Contact	Y	Y	Y	Y	Y	Y	Y	N	N	N	Y	N	N	N	N
	Run onto	Y	Y	Y	N	N	Y	Y	Y	Y	Y	Y	Y	Y	Y	Y
Copper/brass*	Contact	N	N	N	N	N	N	N	Y	Y	C	Y	C	Y	Y	Y
	Run onto	N	N	N	N	N	N	N	Y	Y	C	Y	Y	Y	Y	Y
Stainless steel	Contact	C	N	N	C	C	N	N	Y	Y	Y	Y	Y	Y	Y	Y
	Run onto	Y	Y	Y	N	N	Y	Y	Y	Y	Y	Y	Y	Y	Y	Y
Lead*	Contact	N	N	N	Y	Y	N	N	C	Y	Y	Y	Y	N	Y	Y
	Run onto	C	N	N	Y	Y	N	N	Y	Y	Y	N	C	Y	Y	Y
Plastic/glass	Contact	Y	Y	Y	C	C	Y	Y	Y	Y	Y	Y	C	Y	Y	Y
	Run onto	Y	Y	Y	N	N	Y	Y	Y	Y	Y	Y	Y	Y	Y	Y
Concrete/plaster	Contact	N	N	N	C	C	N	N	C	Y	Y	Y	Y	Y	Y	Y
	Run onto	N	C	N	Y	Y	N	N	Y	Y	Y	Y	Y	Y	Y	Y
Wet timber	Contact	N	N	N	N	N	N	N	C	C	N	Y	Y	Y	Y	Y
	Run onto	Y	Y	Y	Y	Y	Y	Y	Y	Y	Y	Y	Y	Y	Y	Y
Steel*	Contact	C	N	C	N	N	C	C	N	N	C	Y	C	N	N	Y
	Run onto	Y	Y	Y	Y	Y	Y	Y	Y	Y	Y	Y	Y	Y	Y	Y
Cedar*	Contact	N	N	N	N	N	N	N	Y	Y	Y	Y	Y	Y	Y	Y
	Run onto	Y	Y	C	C	C	Y	Y	Y	Y	Y	Y	Y	Y	Y	Y
Butyl rubber	Contact	C	N	N	N	N	N	N	Y	Y	Y	Y	Y	Y	Y	Y
	Run onto	C	C	N	N	N	C	C	Y	Y	Y	Y	Y	Y	Y	Y

4.9.4C Material Compatibility Key



Suitable



Not suitable



May need separation. Use with caution in severe or moist environments

* May cause staining, but not corrosion

Note: • Runoff and contact effects may vary according to the relative size/area of the two materials.

- Most incompatible materials will not react if moisture can be eliminated from area of contact.
- Use with caution - may mean separation required, or unsuitable in severe environments, or when in wet contact.
- Wet concrete includes uncured concrete, fibre-cement, or within plaster walls.
- Dry concrete includes cured concrete not exposed to rain.

4.10 Other Causes of Corrosion

4.10.1 Unwashed Areas

Areas on a building that seldom receive rain-washing gather salt, dust and other contaminants. When condensation, dew or humidity moistens these particles, they react with metal cladding. The reaction is often noticeable as a white zinc corrosion effect, which will precede more serious corrosion.

An unwashed or sheltered area is any surface that is above or inside a line drawn at 45° to any weathertight overhang. Such areas require special consideration, particularly in severe environments.

Unwashed areas include: unlined soffits, roof overhangs, canopies, sheltered walls, and the upper part of garage doors.

Wall claddings receive less effective rain washing than roofs, and may be harder to maintain or replace, so materials for wall cladding should be selected accordingly.

4.10.1A Unwashed Soffits

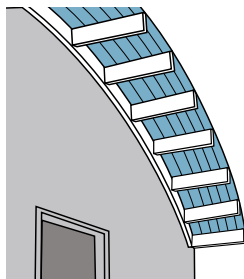

Unwashed soffits comprising areas of main roof are best avoided

4.10.1B Unwashed Wall

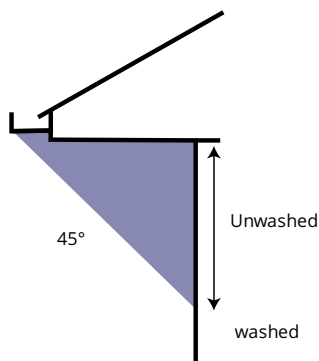

4.10.1C Unwashed Area

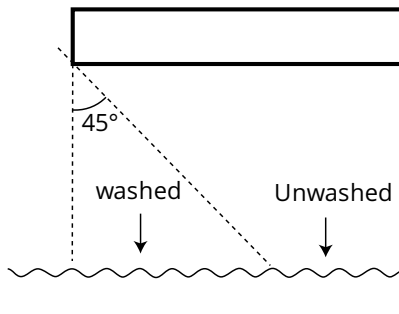

4.10.1D Unwashed Wall Below Soffit



4.10.2 Poulitice Corrosion

Poulitice corrosion or 'under deposit corrosion' is caused when a collection of fine dust – e.g., from earthworks and quarries, or sawdust and shavings from timber processing plants – collects in crevices behind laps or flashings.

These collections increase the time of wetness and retain contaminants.

Bird droppings can contain highly corrosive and adhesive materials that will affect metallic cladding. Birds can also deposit other injurious material, e'g', fish frames and chicken bones.

4.10.3 Solar Collectors and Other Roof Mounted Structures

Solar energy collectors, Heating Ventilation and Air-conditioning (HVAC) systems may be attached directly to the surface of profiled metal roof cladding or mounted on a frame above the roof plane.

For direct fastened solar energy collectors, a complete seal between the photovoltaic (PV) cells and the cladding is essential to prevent water ingress resulting in wet storage corrosion.

Rail mounted systems for solar energy collectors can be installed in a similar manner to HVAC systems and other roof mounted structures. Units may be laid parallel to the roof or oriented at an angle for greater efficiency and easier roof maintenance.

Support frames installed above the roof must have sufficient gap underneath

- to assist with self-cleaning,
- limit the build-up of leaves and other debris,
- provide access for inspection and cleaning, and
- allow air movement to quickly dry areas under the panel.

The minimum recommended gap is 100 mm from the pan, and 20 mm from the crest of a profile. A greater clearance may be required for larger installations or where greater debris deposits are expected.

The support structure may be connected to the rib of clip fixed products; or supported by the rib and attached through the profile to the purlins. The designer must ensure that the design of the roof and the structure is adequate to resist any additional wind and gravity loads associated with the panels.

4.10.3A Clamp Style Fixing Bracket



4.10.3B Purlin Fixing Bracket



Access to the roof for inspection and maintenance must be considered when designing roof mounted structures. The roof cladding should be designed to resist regular roof traffic, or the installation of walkways is recommended.

Wires and conduits penetrating the cladding must be fitted with a gooseneck or proprietary cover to prevent reliance on sealant for weatherproofness and must be installed so that their base does not impede water flow.

4.10.3C Proprietary Cable Hood

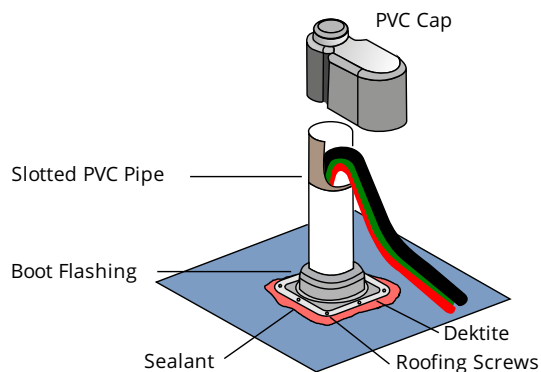

4.10.3D Supported HVAC Installation



A well-designed HVAC installation allows free draining of water, isolates incompatible materials, has little reliance on sealant and avoids extensive dry-pan back flashings

Support structures must be constructed of materials compatible with the roofing material and separated from the roof by a non-absorbent and non-conductive rubber gasket. Typical proprietary support structures are manufactured from aluminium with stainless steel fasteners. Contact between the stainless fasteners and the roof cladding should be avoided, but run-off is acceptable. Contact with, or run-off from, copper onto painted and unpainted steel and aluminium roofs must be avoided.

4.10.4 Hot Water Runoff Corrosion

The combination of hot water and copper is detrimental to all types of roofing, and hot water from copper pipes will exacerbate the corrosive effect of copper itself.

Water from the exhaust pipes of hot water cylinders or pressure relief-valves must not be permitted to discharge onto metal roofs. The copper pipes of solar panels, air-conditioning or other ancillary equipment must be sealed to avoid runoff onto any metal cladding or gutters other than copper.

4.10.5 Walkways

Only aluminium, stainless steel, inert plastic, or hot-dipped galvanized steel framing members are acceptable for support structures above steel cladding and must be supported by the structural members or across the ribs of the profile adjacent to the ribs. They should be designed to allow natural rain washing of the roof underneath.

4.10.6

Capillary Action

4.10.3E Rib Supported Photovoltaic Bracket

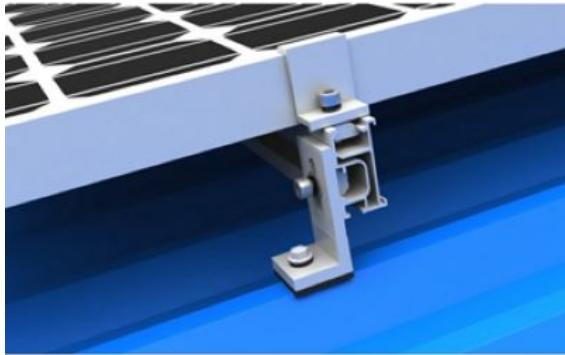

Typical rib supported systems are Manufactured from aluminium.

4.10.3F Tilted Photovoltaic Installation



An example of a Proprietary tilted PV Installation.

While capillary action is both a durability and a weather tightness issue, it is considered here because it affects durability more often than water tightness, although the two are inter-related.

Capillary action is the ability of a liquid to flow into narrow spaces without the assistance of, and in opposition to, external forces such as gravity. It is caused by the combination of intermolecular forces of surface tension in the water and adhesive forces between the liquid and surrounding surfaces.

The effect can be seen in the drawing up of liquids between the bristles of a paintbrush, in absorbent materials such as blotting paper or a sponge, in a burning candle, a fountain pen, or the cells of a tree. The effect can occur in a tube, but also between two closely spaced mating surfaces.

4.10.6A Capillary Action

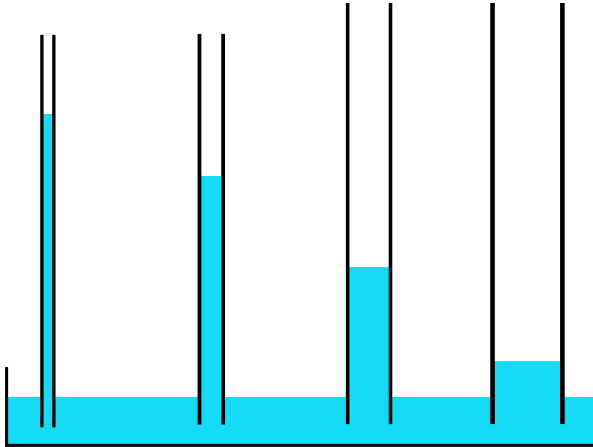

Gravity will affect the degree of capillary action; a low sloping pair of surfaces will attract liquid more by capillary action than a vertical surface, and a narrow tube will draw a liquid column higher than a wider tube.

Capillary action is an important consideration in cladding installation and design, and can be considered in four main areas:

1. Closely stacked sheets of trapezoidal or corrugate profiles, or flat sheet that has the sheet ends exposed to rain, will draw water between the surfaces which can infiltrate a long way into the stack of material. After a short time in the absence of air, it can form volatile corrosive products which are unsightly and detrimental to product life.

While metallic coatings have temporary surface protection against wet storage stain and organic coatings also give some protection, there is no hard and fast rule as to how long this will last; it is up to the roofing contractor to take appropriate measures. Packs of close stacked sheets exposed to water must be fillet or cross stacked to allow natural air movement and drying, before the onset of wet storage stain.

2. Capillary action can take place in the side lap of roofing sheets, or between a longitudinal flashing and the adjacent rib. For this reason, side laps should be designed with a capillary break, and when calculating the water carrying capacity of a profile, the allowable water depth is taken as being to the bottom of the capillary bead, not the rib height.

Even corrugate profiles are designed to have an asymmetrical shape between under and over crest. However, this is not normally as effective as the capillary break on a rib profile. This is one of the reasons why the minimum pitch for standard corrugate is 8°, although it has been proven to perform at lower pitches in short runs if the dimension of the overlap is not too generous and it is not extending into the water table.

With longitudinal flashings, such as barges, the downturn into the pan should not be tight against the rib, but have a gap to avoid capillary action from occurring.

3. Capillary action is also common between the end laps of sheets. When short run sheets were the norm and end laps common, the onset of corrosion normally occurred around the lap despite primer being applied to the surfaces. It was most often concentrated on the upper end of the lap and was caused, not by rain water, but by condensation on the underside of the sheet entering the lap. End laps on roofing should be avoided where possible. Where they do occur, end laps must be sealed

at both ends to avoid ingress of moisture from both internal condensation and external rainfall, and end laps in vertical sheets must be sealed at the top end of the lap.

4.10.6B Roofing Sheet End Lap

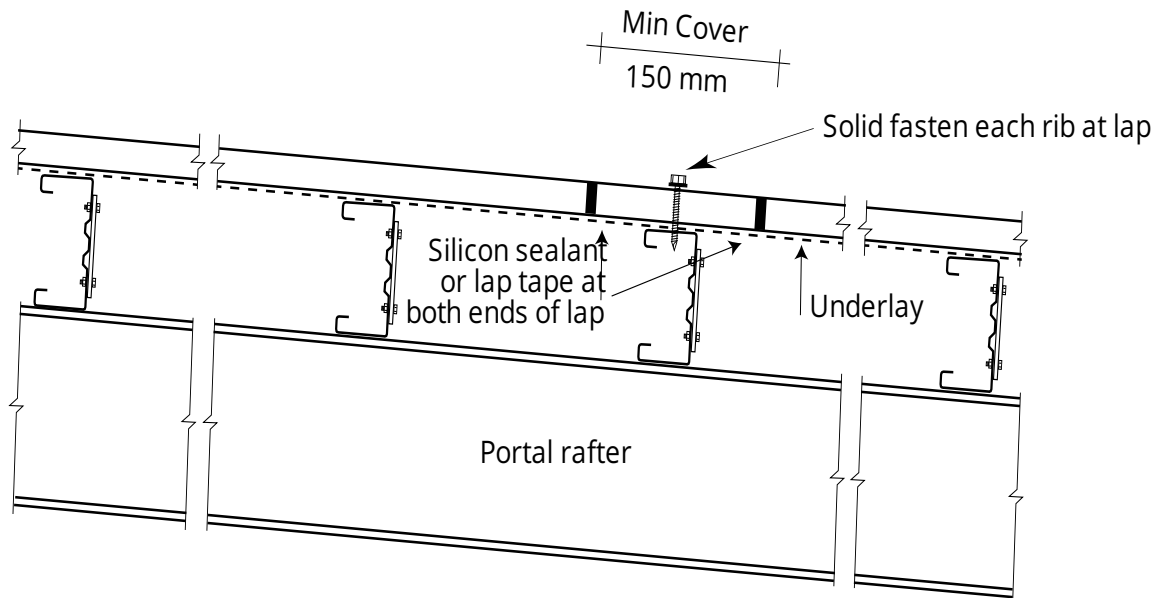

- The adhesive nature of water that causes capillary action can help drive water up the underside of the sheets at the eaves, rather than discharging into the gutter. Therefore, the ends of all sheets laid to a fall less than 8° require a drip edge; and the minimum roof pitch of standard corrugate is 8° , as it is difficult to form a drip edge in that profile. The lower edge of all roofing sheets and flashings laid to a fall of less than 8° must be drip formed into the gutter to prevent capillary action.

4.10.7 Crevice Corrosion/Wet Storage Stain

Roofing materials exposed to the air react with the atmosphere to form a relatively stable surface. Exposing metals to water in the absence of air causes the formation of unstable surface films.

Crevice corrosion occurs in crevices and confined spaces. Crevices are often created because of overlapping flashing or sheets of cladding, or between the sheets of close stacked materials.

Design details that trap moisture, dirt, and debris should be avoided.

Corrosion can appear even with a chemically neutral electrolyte. An example of this type of corrosion is the corrosion on metals underneath paint coatings and "white rust" – the wet storage stain on closely nested zinc coated roofing sheets. Other metals, such as aluminium/zinc coated and non-ferrous metals, can suffer similar damage.

4.10.7A White Rust due to Capillary Action



Capillary action can cause white rust to occur throughout a length of cladding

4.10.7B Bulky Deposits of White Rust



White rust on galvanised sheets causes bulky white deposits to form that can quickly lead to red rust

If end-lapping of roof sheets cannot be avoided, both ends of the lap must be continuously sealed to ensure that neither condensation run-off from the under-surface nor rainwater run-off enters the lap.

Capillary action can cause water to be drawn into closely stacked sheets, resulting in crevice corrosion or wet storage stain on both metallic coated and non-ferrous materials. On metallic-coated steel sheets, the passivation coating gives some temporary protection against this process, as do organic coatings, but longevity cannot be guaranteed for the duration of this protection. On non-ferrous, metals, wet storage stain can commence very rapidly.

Wet packs of sheets should be separated to allow surfaces to dry before substantial storage.

If wet storage stain appears on unpainted surfaces, the degree of erosion of the metallic surface may be slight despite the bulky appearance of the deposits. However, when left unchecked it, can quite quickly lead to substantial degradation. If required, measurements can be taken of the thickness of the material or the metallic coating to determine the extent of erosion.

Even if the damage is superficial, the white deposits must be removed to allow exposure to the air to allow the normal formation of stable surface films. Use a stiff bristle brush; wire brushes are not recommended as they will remove more of the protective coating.

4.10.8 Microcracking

Microcracking is microscopic cracking on the surface.

- Microcracking of the metallic and/or organic coating creates a crevice where the normal protection mechanisms of the coating are compromised. It can lead to premature corrosion failure.

The test requirement for paint adhesion in AS/NZS 2728 and by the NZMRM is a bend test over a nominated number of material thicknesses (T) and it is measured as the internal diameter.

The radius required to avoid microcracking on metallic coated and pre-painted steel is measured externally. To obtain an external radius, add two material thicknesses to the internal diameter, and divide the result by two.

4.10.8A Microcracking : a



$0 T$ internal diameter = $1.0 T$ external radius

4.10.8B Microcracking : b



$(b) 1 T$ internal diameter = $1.5 T$ external radius

4.10.8C Microcracking : c

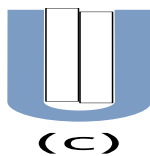

$(c) 2 T$ internal diameter = $2.0 T$ external radius

4.10.8D Microcracking : d

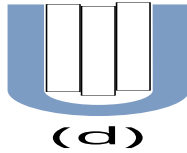

(d) $3 T$ internal diameter = $2.5 T$ external radius

4.10.8E Microcracking : e

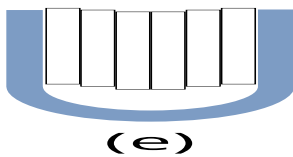

(e) $6 T$ internal diameter = $4.0 T$ external radius

4.10.9 Gutter Leaf Guard

Leaf guards are widely marketed as a way to prevent the build-up of vegetable matter in spouting. They may achieve this objective, but they often result in a build-up of a plant material poultice on the eaves line of the roof.

That can cause premature corrosion of the roof by chemical reaction, greatly increased time of wetness, and prevention of adequate ventilation of the underside of the cladding.

The COP recommends against the installation of such products. Alternative solutions include fitting a durable spouting material such as copper, installing rain heads with a leaf trap, or installing a proprietary leaf-proof spouting system.

4.10.9A Leaf Diverter

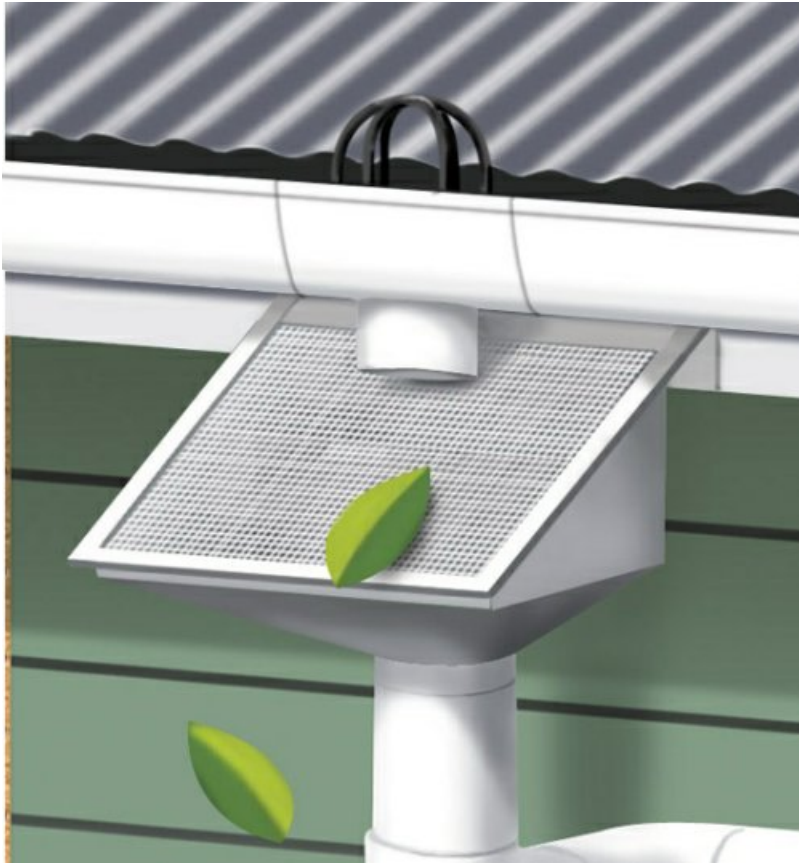

4.10.9B Proprietary Leaf Proof Spouting System



4.10.9C Proprietary Leaf Proof Spouting End Cap



4.11 Inert Catchment

Run-off from inert surfaces such as glazed tiles, aluminium and aluminium-dominant metallic coatings, fibreglass, pre-coated metals, glass or any painted surface can cause corrosion of unpainted galvanised steel and other zinc-dominant metallic coatings. This is known as 'drip-spot corrosion' or inert catchment corrosion.

4.11A Localised Damage due to Inert Catchment



Water sitting on a surface absorbs carbon dioxide forming carbonic acid, which is reactive with zinc. On a galvanised surface, the carbonic acid reacts with the zinc and becomes neutral. On an inert surface discharging into an unprotected zinc surface, the carbonic acid is not neutralised, and reaction will be concentrated on the drip points of the inert surface onto the zinc surface.

As the formation of carbonic acid takes time to occur, inert catchment corrosion is normally seen at specific drip points of dew off a roof, rather than below rain washed painted walls and windows.

4.11B Normal Catchment

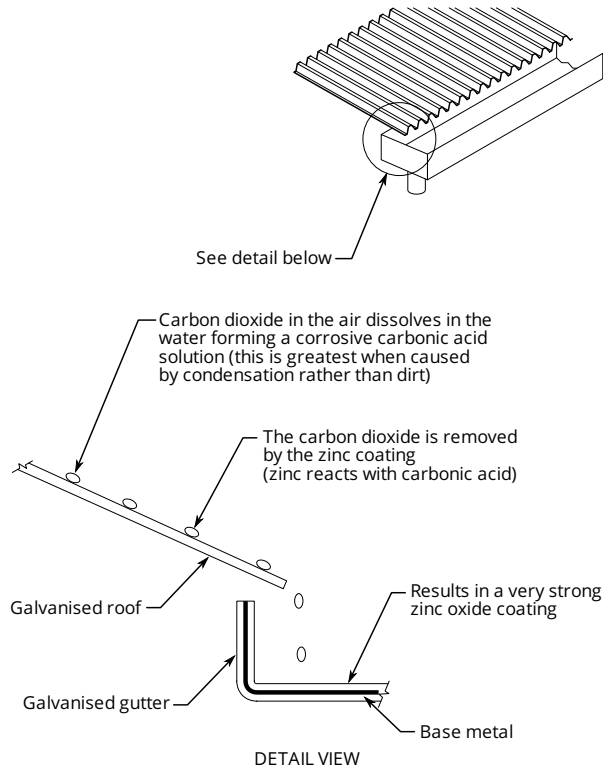

4.11C Inert Catchment

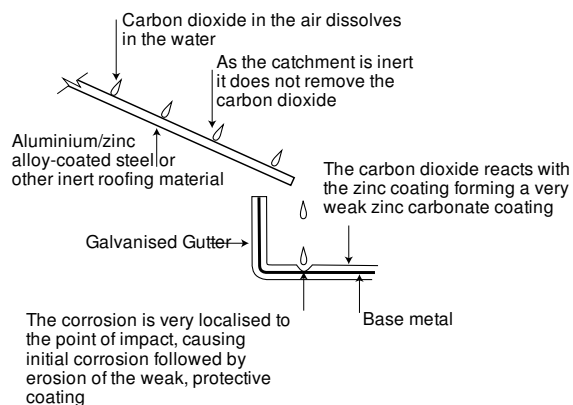

4.12 Ponding

Ponding happens when water is unable to drain from a roof or gutter surface. Possible causes include lack of fall, poor penetration design, and damage to sheet ribs due to excessive spans or foot traffic. The accumulated water increases the time of wetness and can lead to pultice corrosion.

All paint systems on factory pre-painted materials are permeable to a degree and will delay, but not prevent, the corrosive effects of ponding.

Ponding can occur in gutters and spouting when joints or outlets are higher than the sole of the gutter, or when debris is left to accumulate.

To help prevent ponding, the minimum pitch for all metal roof cladding in New Zealand is set at 3°. At pitches of lesser pitches deflection of the structural members or settlement of the building can compromise drainage.

Low pitch roof spans must be sized according to the type and frequency of roof traffic to prevent ponding caused by rib damage, and penetration flashings must be of a free draining type.

4.13 Pitting Corrosion

Pitting corrosion is a highly localised corrosive attack that forms pits which have a very small surface area, but which can be quite deep.

Pitting occurs on non-ferrous metal when the protective passive film breaks down, or where it has been weakened or damaged by contamination. When the break-through occurs in the passive film, the actively corroding pit constitutes the anode and the large passive film surrounding the pit acts as a cathodic surface.

The rate of dissolution of the metal is strongly influenced by the ratio between anode and cathode areas, consequently the "driving force" behind pitting attack can be very strong and deterioration can spread quickly.

4.14 Swarf Staining and Cut Edge Corrosion

Swarf is the term given to the steel debris as a result of cutting or piercing a metal sheet or adjacent metal surfaces.

When cutting steel, any swarf remaining on the sheet starts corroding quickly and causes stains. These stains are often mistaken for early deterioration of the cladding.

To some degree, swarf will normally be evident at the completion of any roof cladding job. The acceptability of swarf depends on how it got there, whether techniques have been applied to minimize it, and the visual exposure of the cladding.

4.14A Light Scattered Swarf



Light, scattered swarf is acceptable in most situations.

4.14B Excessive Swarf



Swarf created by acceptable means of cutting – i.e., power drills, self-drilling screws and shears – will be either loose or lightly adhered to the surface film of painted or unpainted sheets. Most swarf can be removed by daily hosing, sweeping, or blowing which should be done at the end of each day and at the completion of the job. Avoid blowing loose swarf under adjacent cover flashings.

Any remaining swarf will not be in contact with the metallic substrate and will not cause deterioration of the roof, its effect is aesthetic only. Overly aggressive efforts to remove such swarf is likely to damage the appearance of the cladding without enhancing its durability

On highly visible surfaces, a soft rag and plastic spatula can be used to remove more tenacious swarf adhesions, or on painted surfaces, the use of a diluted mild household liquid cleaner might work. Wire brushing, steel wool, or pot scouring cloths must not be used as they will damage the organic or metallic coating.

Swarf created by unacceptable practices, such as the use of grinders and friction power blades on, or adjacent to the cladding, is often hotter on contact with the cladding. The heat may cause it to embed deeply in the organic film and be in contact with the protective metallic substrate.

4.14C Friction Cut Edge



Friction cutting that creates swarf can also cause heat damage to metallic and organic protective surfaces.

This can severely affect the substrate; removal is difficult or impossible to achieve without mechanically damaging the decorative and/or protective coatings.

Swarf is not the only problem that cutting with friction blades can create. Such blades will often produce excessive heat at the cutting edge, which will degrade the organic and metallic coatings.

4.14D Cut Edge Corrosion

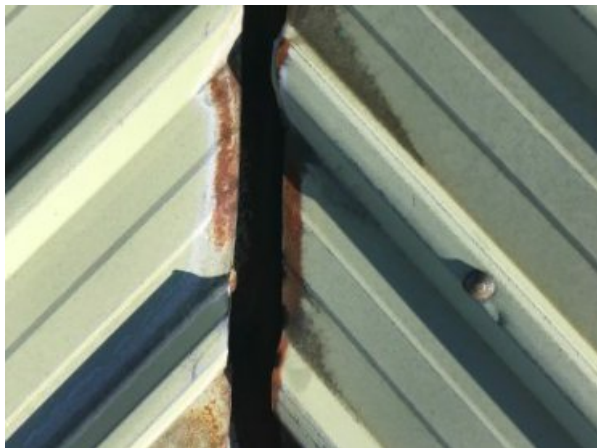

Often roof damage is caused by sub-trades accessing the roof after installation. Roofers and other trades must be aware of how they are treating the material they are working on and the effect it may have on adjacent surfaces.

Where work is done above or adjacent to an installed roof surface, or where the roof is used as a work platform for subsequent work, the main contractor must take steps to make sure the existing roof remains undamaged.

4.14E Mechanical Damage



This roof shows evidence of mechanical damage to the coating, rib traffic damage to adjacent ribs within a purlin span, and excessive swarf by unacceptable cutting practices. In this case the only logical remedy was replacement.

4.15 Clearances

To ensure the edge of the flashing does not mechanically remove protective coatings on the cladding, there must be enough clearance between the edge of a vertical flashing, or a notched flashing, and the cladding. Similarly, the edges of cladding running parallel to flashings, such as at a window head, should have clearance to avoid mechanical damage and allow drainage.

Having the lower edges of flashings apart from the surface they are covering helps to improve the cut edge durability of the flashing. Kick-out barge details are preferred to bird's beak barge details for the same reason. The size of the clearance is not critical, but typically it is more than 5 mm.

4.15A Window Head

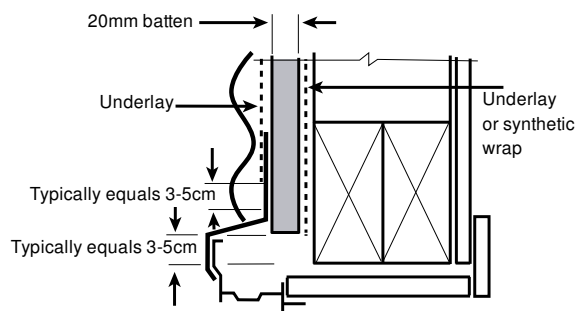

4.15.1 Ground Clearance

Clearance is required between the bottom of profiled metal cladding and large flat surfaces. For timber-framed dwellings, E2/AS1 requires a clearance of 35 mm to an adjacent roof, 100 mm to paved ground, and 175 mm to unpaved ground.

4.15.1A Ground Clearance Detail

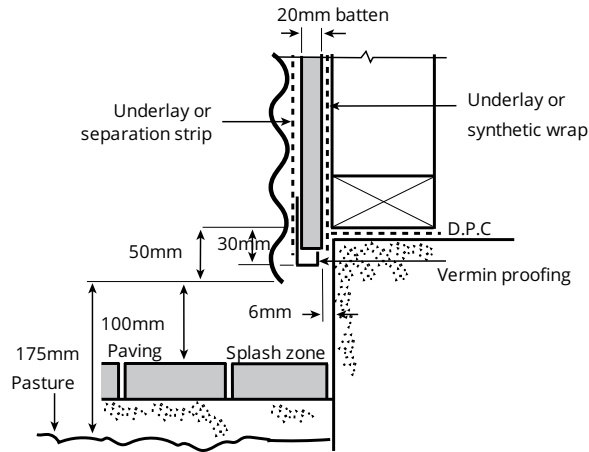

The clearance requirements for unlined buildings are less than that required for lined buildings, as the absence of lining enables the inner face of the cladding to dry more rapidly, and inspection and maintenance of the framing can be practically achieved.

4.15.1B Importance Levels from NZS 3604:2011 (Table 1.1)

Level 1 Structures presenting a low degree of hazard to life and other property

1

Level 2 Normal structures and structures not in other importance levels

2

Level 3 Structures that may contain people in crowds or contents of high value to the community, or may pose risks to people in crowds.

Level 4 Structures with special post-disaster functions.

4

4.15.1C Minimum Ground Clearance for Lined Buildings

**Minimum Design Ground Clearance for
Profiled Metal Cladding on Lined Buildings of Importance Level 2.**

Ground Type	Minimum Clearance
Garage door opening	25 mm
Walls under canopies	35 mm
Paved	100 mm
Unpaved gravel	125 mm
Unpaved lawn	150 mm
Unpaved pasture	175 mm

Importance level 1 buildings may have a lesser clearance provided occupant maintenance prevents the build-up of debris against the cladding.

Greater clearance may be required where gardens abut a wall, where lawn grasses are not grazed or maintained, or where soil spillage from adjacent banks may occur. Future landscaping effects on ground levels must also be considered.

4.15.2 Site Management

The effectiveness of clearances in achieving durability requirements is subject to the occupant ensuring that vegetation, debris, and soil do not build up against the cladding surface. Design clearance from a surface is no guarantee of durability as effective clearances are subject to site development, occupant behaviour and building maintenance.

4.15.2A Cladding Open to Air



Cladding which is open to air will experience the normal wet/dry cycles for which it is designed.

4.15.2B Vegetation in Contact with Cladding



Vegetation or earth in contact with the cladding will increase the time of wetness and may contain corrosive compounds.

The separation of profiled metal claddings from corrosive surfaces such as wet timber or concrete is more critical at the bottom end of cladding, where high humidity levels may be experienced for extended periods. This may take the form of a 3 to 6 mm gap, an inert self-adhesive tape or a PVC vermin strip.

Internal environments are also important, ventilation must be adequate for the building use, and absorptive of corrosive substances must not be in prolonged contact with the external or internal face of the cladding or structure.

4.15.2C The Result of Debris Build-up Against Cladding



Allowing build-up of material against wall cladding can result in corrosion regardless of nominal ground clearance.

4.16 Materials

Metals used in the roof and wall cladding industry in New Zealand are:

- steel coated with zinc - Galvanised steel;
- steel coated with an alloy of aluminium and zinc, sometimes with the inclusion of other minority elements;
- aluminium;
- copper;
- zinc;
- stainless steel; and
- lead.

*Many of these can be coated with an organic coating, including acrylic, polyester and PVDF.

4.16.1 Steel

4.16.1.1 Metallic Coatings

For most of the nearly 200-year history of lightweight steel cladding, the protective metal coating has been made from zinc (usually with minor additions of other metals), and this is called galvanised steel. It works by the zinc sacrificing preferentially to the steel.

In the second half of the 20th century research looked for metallic coatings which would provide longer life. Aluminium was tried as a coating material because of its passive surface, but it was not satisfactory on its own. However, aluminium alloyed with zinc and other metals produced more corrosion proof products than any metal on its own. (See 4.4.2 Barrier Protection.)

We now have two groups of metallic coatings for steel cladding products – zinc-dominant coatings, which primarily provide sacrificial protection; and aluminium-dominant coatings, which primarily provide a barrier protective coating of aluminium oxide. Coatings containing both aluminium and zinc are now the preferred coating for roof and wall cladding products, although zinc-based coatings continue to predominate for various other products.

The composition and weights of these coatings are described in detail in AS 1397:2011. The following sections discuss metallic coatings in the order in which they appear in AS 1397, not their rate of use in the market.

4.16.1.1.1 Coating Thickness

Steel was zinc-coated for many years by dipping short lengths of flat or profiled sheet metal in a bath of molten zinc, and the steel was then hung to cool while the excess zinc coating drained off.

More than sixty years ago manufacturers developed a continuous hot dipping method. During the continuous hot dipping process, the steel coil is run through a bath of molten metal. The thickness is controlled by blowing off the excess coating with air jets applied to both sides of the strip as it leaves the molten metal bath.

Continuous hot dipping, as opposed to the batch immersion process, is more cost-effective and allows for greater control of the consistency, thickness, and surface condition of the metallic coating.

It is a similar process to that for continuous paint coating, shown in [4.17.1.1 The Paintline Process](#), with priming, coating, and ovens replaced by the molten metal tank and blow-off section.

The atmospheric corrosion performance of a hot-dipped zinc coating is closely proportional to its thickness.

The thickness of coatings in micrometres (μm) can be measured with a non-destructive magnetic induction meter or similar device which can then be converted into grams per square metre (g/m^2).

4.16.1.1.1A Coating Thickness

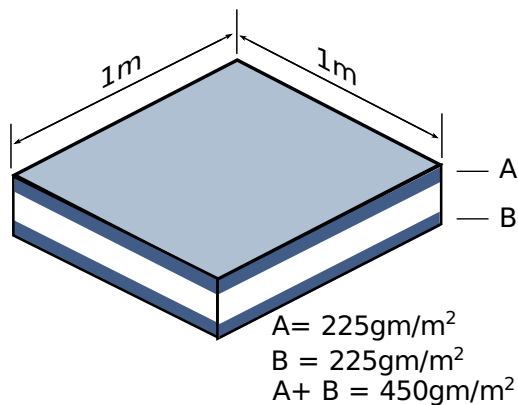

There is confusion about the method of describing the coating thickness of coil-coated sheet and strip products in g/m^2 , compared to products that were hot-dipped after fabrication. The coating thickness of sheet and strip refers to the collective amount of coating on both sides of the sheet, effectively dividing the coating weight by half. It is invalid to equate the coating weight in g/m^2 of hot-dipped zinc coatings on fabricated products, such as nails and screws, with that of metallic coatings on sheet and coil; the coating thickness of the fabricated products relates to one surface only.

A micron (μm) is one-thousandth of a millimetre.

4.16.1.2 Galvanised Steel

Zinc Coating, commonly called galvanising, is still one of the most common metallic coating processes for steel. Galvanising describes various methods of adding a metallic zinc coating to steel to give it cathodic protection; also known as galvanic protection.

Galvanised steel is classed as a "Z"-coating and has a bold crystalline pattern or spangle, a random geometric pattern that resembles frost on a window.

There are many processes for galvanising, but only products dipped or immersed in a bath of molten zinc can be called hot-dipped galvanised, the process used for the metallic coating of steel roof and wall cladding.

The thickness of the coating can be more precisely controlled on a continuous coil galvanising-line than it can be with other methods.

The standard coating weight for unpainted galvanised coil and sheet used for roof and wall cladding is 450 g/m², designated Z450, but other coating weights are available. The coating weight for products intended for painting is 275g/m², and it is designated Z275.

Since the advent of ZM coatings, minimised spangle zinc coated products, typically used for painting, are now designated with the "M" after the weight, e.g., Z275M.

The process of zinc coating by electro-plating gives a much thinner protective film and is not considered suitable for painted or unpainted cladding materials exposed to the weather.

4.16.1.3 ZA Coatings

ZA coatings are a zinc-aluminium alloy coating consisting of 95 % zinc and 5% aluminium by mass, with the addition of lanthanides. It is commonly known as Galfan® and is designated ZA in AS/NZS 1397. As an European product it generally conforms to EN 10214..

ZA serves the same purpose as galvanised Z and AZ coatings, but has different corrosion characteristics than both.

ZA coatings are not currently available in NZ or Australia.

4.16.1.4 ZM Coatings

ZM coatings are zinc-aluminium alloy coatings with a majority of zinc and a small amount of magnesium. Steel with a continuously hot-dipped coating of zinc with 5 -13% aluminium and 2 - 4% magnesium is designated in AS 1397:2011 as ZM. In New Zealand, it is commonly marketed as ZAM.

The coating weights are similar to Zinc coatings, with ZM 240 used for products which will later be coil coated and ZM 450 for unpainted products.

Unpainted ZM products have been used for roofing accessory and rainwater cladding applications in New Zealand, but are more commonly found in factory pre-painted products.

4.16.1.5 AZ Coatings

AZ coatings are zinc-aluminium alloy coatings with a majority of aluminium. AZ coating, marketed as Zinalume® steel, is an alloy of zinc and aluminium which is now the most commonly used coating in New Zealand for protecting steel roof and wall cladding.

AZ coating is applied in the same way as other coatings, but with a pot temperature at about 140°C higher than galvanised coating, and it is rapidly cooled to provide a dual-phase microstructure.

The alloy consists of 50 to 60% aluminium, zinc, and a small addition of silicon. In New Zealand, the ratio is nominally 55:45. These percentage ratios are by mass; by volume, the percentage ratio changes to approximately 80% aluminium and 20% zinc. Volume is probably a more realistic measure of its nature.

The alloy coating thickness generally used for steel roof and wall cladding is 150 g/m² (AZ150). This coating is approximately the same thickness (0.04 mm) as Z275 zinc. AZ200 coatings are available as a substrate for organic coated products to be used in very severe environments.

An AZ coating protects steel both as a barrier and sacrificially, as the aluminium content provides a barrier, while the zinc content of the coating will sacrifice itself to protect the base steel.

The AZ coating is finer grained than zinc alone and has a silver matt hue with a lightly visible spangle. This finish has a relatively high level of initial reflectivity, which darkens over time.

A thin acrylic film is applied during manufacture in New Zealand. The acrylic film acts as a roll forming lubricant and minimises finger marking and surface discolouration.

4.16.1.6 AM Coatings

Adding magnesium to an aluminium dominant zinc-aluminium alloy coating improves the cut edge corrosion resistance to a similar level as zinc coating, but still confers the improved surface protection and slower erosion rate of AZ coatings.

Steel with a continuously hot-dipped coating of 47 - 57% aluminium and zinc, with the addition of 1 - 3% magnesium by mass is designated in AS 1397:2011 as AM. It is not currently sold in NZ but is under test.

Coating weights may be AM100, AM 125 or AM150.

4.16.2 Stainless Steel

Stainless steel is a durable, corrosion-resistant material used in harsh environments when a non-weathering finish is desired. Chromium forms a tenacious oxide protective film on stainless steel that is transparent and self-healing, as it will repair itself on exposure to the atmosphere.

Stainless steels are resistant to most chemicals, but are subject to crevice and pit corrosion (see Wet Storage).

Some light surface staining known as tea staining may appear, but it is not damaging to the product.

Most stainless steel roof and wall cladding, flashings and panels in New Zealand are made from the 300 series of austenitic non-magnetic stainless steel, which contain chromium, nickel, and manganese, with 304 and 316 being the most common grades.

Grade 304 stainless steel is an alloy of 18% chromium and 8% nickel that provides high corrosion resistance and is known as an all-purpose alloy.

Grade 316 stainless steel should be specified where tea staining must be avoided. It contains 16% chromium, 10% nickel, with 2% molybdenum added, which increases resistance to staining and corrosion.

Grade 445 ferritic stainless steel is now available in New Zealand, which combines the corrosion resistance of grade 316 with formability approaching that of carbon steel. As the work hardening of 445 is much lower than with austenitic grades, it can be formed in a similar way to carbon steel and is more easily sheared.

Grade 445 stainless steel contains 22% chromium and 1.2% molybdenum and no nickel. It has lower thermal expansion than other grades, so it is less likely to distort in the heat of the sun. The yield stress and hardness of 445 is higher than 304 and 316, but the tensile strength and elongation properties are lower.

The corrosion resistance grade of 445 is similar to grade 316 in most marine and aggressive industrial environments.

Stainless steel is available in various mill finishes from dull matt to highly polished. The most common finishes for roof cladding and sheet metal flashings, are those designated as 2B and 2D.

The 2B finish is a bright, cold-rolled finish that is highly reflective and 2D is a dull finish that is less reflective. BA is a bright reflective surface only suitable for decorative cladding in thicker gauges. Embossed patterns are available that reduce visible distortion and minimise glare and reflection.

Stainless steel should not be cleaned with steel wool, but stainless steel wool or synthetic abrasive pads can be used. Cleaning should be done with care as roughening the surface may promote further stains.

Stainless steel fixings should be used with stainless steel sheet to avoid dissimilar metal corrosion. The fastener grade must match the grade of the cladding.

There is no well-defined yield point for stainless steels. Fully annealed or standard annealed tempers are used for ease of forming with 304 and 316 having an approximate yield strength of 290 mPa.

Austenitic stainless steels require different forming techniques than other metals, and are known to be tougher and more difficult to form than carbon steel of the same thickness, e.g., when shearing stainless steel the equipment capacity should be increased between 30% - 50%. Because of the toughness of the metal, sharp cutting edges dull more quickly than when used with carbon steel.

Although stainless steel is not much harder than mild steel, increased power is necessary to form it because of its high ultimate strength and its higher work hardening rate. As most forming machines are rated for the heaviest gauge steel this capacity should be de-rated by 40%.

Precautions should be taken not to contaminate the surface of the metal by inclusions from roll forming or folding equipment. It can appear as rust spots on stainless steel, which is detrimental to performance. Stainless steel coil and sheet can be supplied with a strippable film on both faces to avoid this contamination.

4.16.3 Aluminium

The aluminium alloys used in New Zealand for roof and wall cladding are included in the 5000 series.

- Aluminium 5005 has excellent workability, weldability and corrosion resistance.
- Aluminium 5052 is a higher strength marine grade alloy with exceptional resistance to corrosion in marine or industrial environments.

Following strain-hardening of aluminium alloys, tempering increases the ductility by low-temperature heating, and their description regarding hardness relates to the last number, e.g. H12 or H32.

The description of tempers given to aluminium alloys can be confusing because the different alloys are strain hardened in different ways. As a result, different alloys with the same hardness description may have significantly different yield strengths.

Pure aluminium (99%) can be used as a soft edging for ridge or apron flashings required to act as a wind barrier.

Aluminium alloys are available in three surface finishes.

- Mill finish: A smooth, lustrous finish which will dull relatively quickly.
- Stucco Finish: An embossed mill finish, which reduces the specular reflectance of mill finish sheet.
- Painted Finish: A range of painted finishes are available similar to those offered in painted steel.

The high reflectance and emissivity of unpainted aluminium can reduce heat transmission considerably.

Aluminium develops a thin oxide film on the surface that is impermeable to most airborne contaminants, except for strong alkalis and acids.

4.16.3A Aluminium Hardness End-use

Note: Typical stocking of 5052 alloy, H36 allows for rollforming both corrugate and trapezoidal profiles. Trough section may require H34 material. H36 material can be used to manufacture most flashings, except those requiring soft edging or hemming.

Alloy;	Yield Minimum	Typical Use
5005 – H32 Quarter Hard	85	Lockseam
5005 – H34 Half Hard	105	Folding
5052 – H32 Quarter Hard	160	Lockseam
5052 – H34 Half Hard	180	Folding and curving
5052 – H36 Three Quarters Hard	200	Rollforming and folding
5052 – Fully Hard220	220	Rollforming

4.16.4 Zinc

Zinc is a traditional roof cladding material and weathers to a dark grey patina after environmental exposure, like galvanised steel, except there is no spangle effect on the surface. Zinc roof panels and flashings are commonly 0.7 mm thick, although heavier gauges can be used. Zinc roofs are usually fully supported on sarking.

The staining potential of zinc run-off onto other surfaces is less than that of copper and lead. Flat zinc panels must be adequately vented from underneath and are available with a high-build lacquer coating to help prevent corrosion of the under-surface.

Zinc has approximately twice the thermal expansion coefficient as steel, so allowance for expansion must be made accordingly.

Under 7 °C the metal becomes brittle and is difficult to form without fracturing.

Zinc used for roof cladding generally contains small percentages of titanium and copper, which add to the properties of pure zinc.

Zinc is also available in a range of pre-patinated surfaces.

4.16.5 Copper

Copper is a naturally durable product.

Copper grades 122, 110, and 102 may be used in construction. Grade 122 is the most commonly used; it has been deoxidized with phosphorus, which makes it weldable. The other grades cannot be welded but can be soldered.

Copper darkens in reaction to the atmosphere. Near seawater or industrial sources of sulphur-containing gases, a green patina may develop in time. In different environments, the weathered colour may vary from dark brown to almost black.

Copper-containing alloys, such as brass and bronze, are available when different colours are requested or for accessories requiring greater strength.

Copper is more malleable than steel sheets, and annealed copper is used for hand folding or where a high degree of formability is required. Roll formed roofing, wall cladding, gutters, spouts, and flashings are typically made from half hard copper. Copper roofs are normally fully supported on sarking.

Copper must be protected from contamination when being processed with tools that have been used to process other metals because the resulting inclusions might cause pit corrosion.

Neither copper nor run-off from copper should come in contact with less noble metals, as it will cause galvanic corrosion. Avoid installing copper in contact with or receiving run-off from bituminous material or other acidic surfaces, because it prevents the formation of the protective patina, causing discolouration and a shortened lifespan.

4.16.6 Lead

Historically, lead has been a popular choice for roof cladding and flashings, because it is naturally durable and is easily shaped using hand tools at ambient temperatures, without the need for softening or annealing.

Lead has an inherent lack of mechanical strength and is laid on solid sarking. It has high thermal movement and, over time, there is a risk of distortion and lead sheet cracking. Sheet lead is available in weights from 6 kg/m² to 40 kg/m².

The thinner the lead, the shorter the length should be. A maximum length of 1500 mm or less than 1.5 m² is ideal.

Run-off from a new lead roof can stain other metals with a white lead carbonate. Application of a proprietary product or boiled linseed oil and mineral turpentine mixture can avoid that happening.

A factory applied cured coating that inhibits the contact between lead and oxides with water is available. The lack of contact reduces the potential for run-off staining other metals, and of lead entering ground water systems. Avoid using lead roofs to collect potable water.

4.16.7 Translucent Sheeting

Translucent sheeting should be manufactured from naturally durable products or have a protective surface film to avoid ultra-violet degradation. (See Natural light for more information.)

4.16.8 GRP

GRP is a composite material made up of polyester resin, reinforced with glass fibres. It is protected from UV erosion by a surface coating consisting of a gel or laminate. The composite is extruded and set over forming moulds to match specific roofing profiles.

GRP can often be used as translucent sheeting or it can be supplied with a clear, or opaque gel coat to the weather surface to provide a high level of corrosion resistance to aggressive atmospheres, where coated metal or even non-ferrous metals may not perform as required.

Examples of use can be found in extreme environments such as wool scouring plants, fertilizer stores, tanneries, acid plants and smelters, abattoirs, compost plants, galvanizing plants, and buildings in harsh geothermal areas.

Where an entire roof is clad in GRP, (rather than individual sheets separated by metal sheets as in a typical case of translucent sheeting), it affects the trafficability and safety requirements. If a GRP roof is required to be accessible, it can be manufactured incorporating woven roving reinforcement into the resin matrix to make it trafficable. Another option would be to install stainless steel safety mesh under the roof cladding, if required.

4.17 Organic Coating

4.17.1 Pre-painted Factory Finish

The performance of metallic coated profiled metal can be enhanced by the application of an organic (“paint”) coating. In pre-painted steel coil this is applied continuously as a two-part primer/topcoat system, prior to the material being roll formed into profile.

The different combinations of metallic coating/primer/topcoat all have different characteristics and must be matched to the material and the environment in which they are to be exposed.

The primer and the topcoat have different performance requirements to fulfil.

4.17.1.1 The Paintline Process

4.17.1.1A The Paintline Process

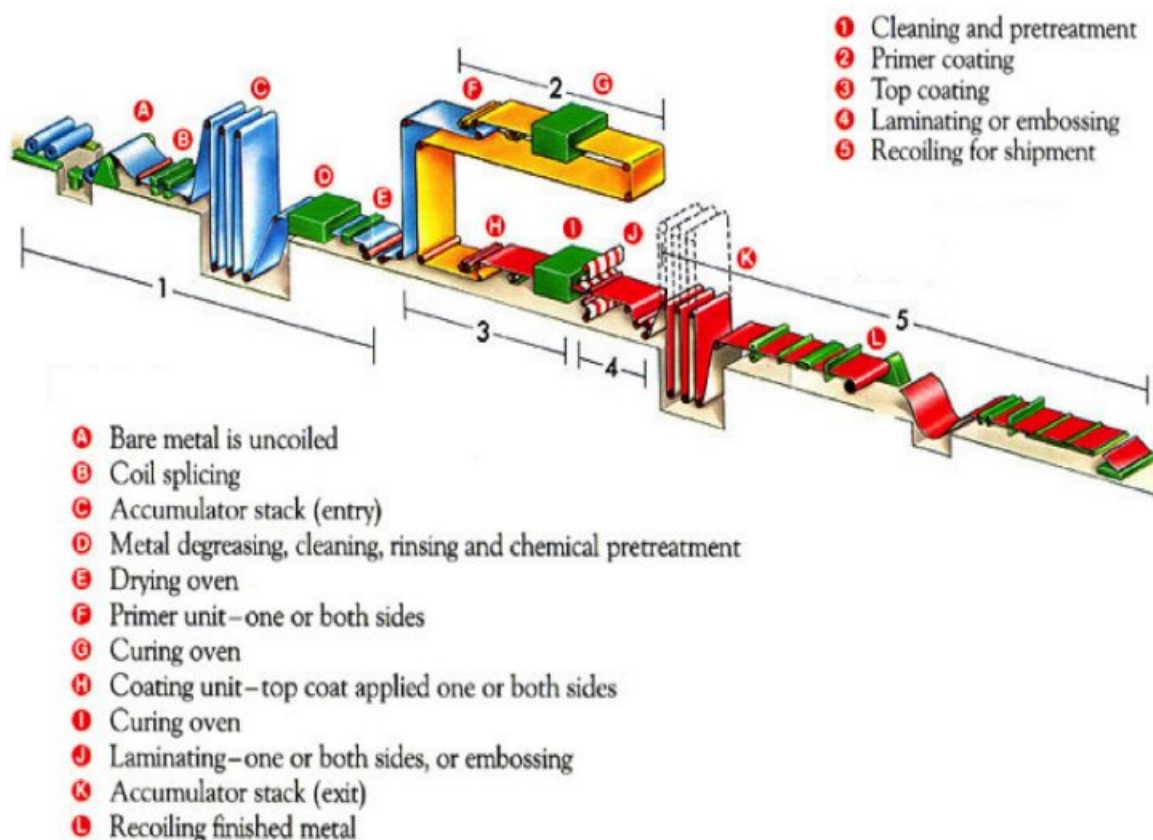

4.17.1.2 Primer

The purpose of the primer is to adhere to both the substrate and the topcoat, and to give added corrosion protection. Primers used on coated steel coil have anti-corrosive pigments which inhibits corrosion through an electro-chemical reaction.

4.17.1.3 Top Coat and Backer

This is the outer skin and it must give the desired appearance. In terms of durability, it provides a measure of barrier coating while still being breathable, and prevents UV degradation of the primer.

Functionally the top coat must be hard enough to prevent excessive marring during profiling and installation; and when in use, it must:

- be flexible enough to form to relatively tight bends without excessive micro-cracking;
- be resistant to fade in NZ's harsh environment;
- withstand extremes of temperature; and
- be a suitable surface for the collection of potable water.

More recent innovations include solar reflectance technology to minimise the amount of solar heat gain gathered by the cladding

Backer coats generally have the same primer and a thinner top coat than the upper surface. Double-sided systems can be specified for areas where the underside is seen, but in external environments these will be exposed to salt spray and other contaminants, and it cannot be assumed that the underside will last as long as the rain washed top surface – even with regular maintenance.

As paint formulations from different suppliers may have different performance characteristics, it is important that cladding and accessories are supplied from the same manufacturer as differing weathering characteristics may result in visible variance in appearance.

Surface coating must comply with AS/NZS 2728. Cladding and flashings must come from the same source and have the same coating specification, so that fade rates are similar. Fade rates must not exceed those stipulated in AS/NZS 2728. All coatings must be lead free and suitable for the collection of drinking water.

AS/NZS 2728 has been deemed ambiguous in that it can be interpreted as allowing accelerated testing to determine colour fastness and durability. Such tests have been found to be an unreliable indication of a system's performance in real-life situations. MRM has therefore adopted an interpretation of this standard as the compliance standard for its members. In the MRM standard, the four-year real-life testing for durability and colour fastness are clarified as being Normative (Compulsory).

4.17.2 Post-Painted Factory Applied finish

This coating system is most commonly used for pressed metal tiles.

Where a coating is applied to a Metallic coated steel or Aluminium substrate after the profile of the roofing sheet has been formed is referred to as a Post-Painted Factory Applied Finish. The metallic substrate may have a coil coated primer, coil coated anti-finger print coating, a factory applied post painted primer or be cleaned and

treated to suit the application of the coatings in a factory environment.

Post Painted coating applied to the substrate vary from smooth matt or gloss painted finishes and textured granule finishes bonded to the substrate with high build coatings. The dry film builds are high compared to pre-primed or coil coated products and the films seal any micro-cracking of the metallic coating that may have occurred in the forming process.

The corrosion performance of the post painted factory applied finished products is influenced by the substrate. The use of Aluminium Zinc metallic coating (AZ) has been proven to work extremely well with the post painted finishes in almost all environments.

The coatings are durable with expected first time recoating maintenance of over 15 years. Touch up of these coatings is possible as the same coating formulation used can be applied in the field. As with any organic coating there will be a gradual breakdown of the resin systems which may result in chalking of the surface.

Chalking is the result of erosion of the surface coating and slight colour changes may occur as the surface resin is eroded. The extent of change depends on pigments used and also the gloss level, a coating that started out as a matt finish will change very little while a gloss finish will appear to have changed more.

Granule-textured finishes use crushed rock that is either natural or natural rock with the surface coated with a ceramic coating that incorporates light-fast inorganic pigments. Both the natural rock and ceramic coated granules provide exceptional long term colour durability. The coatings used to adhere the granules to the substrate are designed to be flexible in all environments and, although durable, the coating is protected from UV by the UV opaque granules.

A clear coating is applied to the granules during the coating process, which helps bond the granules into the adhesive base coating and provides a robust surface reducing any damage during the transportation and installation process. As this clear coat weathers, it exposes the natural or coated surface of the granules, which is slightly duller than the initial finish.

4.17.3 Powder Coating

Powder coating is generally used to colour match accessories used with pre-painted steel cladding and rainwater goods. The use of powder coating on metallic coated steel roof and wall cladding and flashings is not recommended for the following reasons.

- It will fade at a noticeably different rate to adjacent pre-painted metal surfaces.
- Powder coated products are length limited by the size of the curing oven and cannot be re-formed after coating.
- Drilling or cutting of the sheet after powder coating will create an exposed edge vulnerable to under-cut corrosion.
- Standard powder coating does not have the corrosion resistance of pre-painted metal and is vulnerable to post coating damage and edge creep corrosion.
- It is difficult to obtain adhesion to powder coated surfaces when overpainting, and the remaining powder coat surface may not provide a good substrate for such.

Power coating may be used to colour match accessories but cannot be relied upon to increase durability, unless specific pre-treatment and powder coating systems are specified and applied.

4.17.4

Lap Priming

End laps should be avoided where possible. Side laps on profiled sheets do not require priming as they are designed with capillary grooves to drain naturally, or other means to avoid the accumulation of condensation or rainwater.

4.18 Accessories

4.18.1 Fastener Durability

All cladding fasteners must be compatible with the material, suitable for the environment and a durability equivalent to that of the cladding material. All exposed fasteners must have a minimum durability of Class 4. (See [17 Testing and MRM Standards](#))

Only aluminium or stainless steel screws and washers should be used on pre-painted aluminium roof and wall cladding. Stainless steel fasteners must not be allowed to come into contact with the cladding and should be installed through oversize holes.

Sealing washers must be non-conductive to prevent electrical contact between the screw, the metal washer and the cladding surface.

Steel cladding screws can be subject to hydrogen embrittlement when they are hot dipped galvanised. Alternative methods of galvanising, such as peen plating and other metallic coatings, are generally used in combination with an organic coating.

Care should be taken to minimise damage to the head of the nail or screw when using colour matched painted hot-dipped galvanised nails, bolts and screws.

Sandblasting in exposed conditions can significantly reduce the coating thickness and the longevity of the fastener.

Premature failure can result when the shanks of the screws and the eaves purlin are exposed to sea spray, and a high-fronted gutter is recommended to help prevent this.

The performance of the shank of the fastener is also affected by internal environments when the contaminant is inside the building, e.g., animal shelters, fertiliser works.

All fasteners should be easily identified by a code stamped on the head to identify the manufacturer and the coating class.

4.18.2 Screw Guns

To avoid damage to the coating to the screw-head, drivers should not be of the impact type and should be fitted with a snug fitting driver bit.

4.18.3 Sealant

Sealant should be neutral cure silicone or MS polymer.

4.18.4 Underlay

Underlay should have durability no less than the cladding material, and be compatible in contact with the roofing material.

4.18.5 Underlay Support

Galvanised wire netting or mesh can be used to support underlay where the internal environment is not aggressive, but is not to be used with painted aluminium.

Plastic mesh, tape or string may be used to give support at a maximum of 300 mm centres. These alternatives should be used when underlay support is required with aluminium cladding. Ensure that the underlay-support fasteners do not come in contact with the underside of the cladding.

For buildings with harsh internal environments, stainless steel, or PVC-coated mesh and netting are available. PVC-coated mesh may suffer degradation from UV radiation if used externally or when it is exposed to high levels of direct or reflected sunlight.

5

Roof Drainage

This section considers the design of water drainage from the time it hits the roof cladding to the time it enters the downpipe. As the design considerations are similar, this also includes the discharge from gutters and troughs within the roof plane, valleys, internal gutters, and external spouting.

The Roof Drainage section gives guidance for compliance with NZBC Clause E1 Surface Water. It describes how to drain rainwater effectively from roofs and gutters.

The Code of Practice provides several interactive calculators:

5A Capacity Calculations

Gutter Capacity	5.4.7 Gutter Capacity Calculator
Valley Capacity (both symmetrical and asymmetrical)	5.5.7 Valley Capacity Calculator
Downpipe Capacity	5.7.3 Downpipe Capacity Calculator
Maximum Area Above Spreaders	5.8.1 Maximum Area Above Spreader Calculator
Maximum Area Above Penetrations	9.4.4 Maximum Area Above Penetration Calculator
Maximum Run	7.1.4 Maximum Run Calculator

5.1 NZBC: Clause E1 – Surface Water

Objective

Safeguard people from injury or illness, and property from damage, caused by surface water

Functional Requirement

Buildings and sitework shall be constructed in a way that protects people and other property from the adverse effect of Surface Water.

Performance

Surface water from an event that has 10% probability of occurring annually that is collected or concentrated by buildings, shall be disposed of in a way that avoids damage or nuisance to other property.

Surface water resulting from an event with a 2% probability of occurring annually shall not enter buildings.

5.2 Roof Drainage Terminology

5.2A Roof Drainage Terminology as used in the COP

Terminology Usage in the Code of Practice

Freeboard	The height of the watertight portion of a gutter or profile above the design water level at maximum rain intensity. This is to allow for wave action or impediments in the sole of the channel that may otherwise cause overflowing.
Gutter	A channel formed to collect and carry water away from a roof, variously described as internal, external, box, eaves, valley, secret, hidden, and raking. <i>Spouting</i> specifically refers to an external gutter.
Hidden Gutter	An internal gutter that runs parallel to the roof pitch. This is commonly found beside penetrations positioned close to the eaves.
Internal Gutter	A gutter inside the building envelope. In the COP terminology, this applies specifically to those that run transverse to the roof pitch. See also Hidden Gutter, Secret Gutter.
Raking Spouting	Spouting that runs at an oblique angle to the roof.
Secret Gutter	An internal gutter that runs at an oblique angle to the roof pitch. This is commonly found where a roof runs into a raking wall or barge.

5.3 Roof Drainage Design

The objective of roof drainage systems is to maintain a weatherproof building, to minimise the risk of injury or inconvenience due to flooding, and to avoid potential monetary loss and property damage – including to the contents of buildings.

Roof drainage design requires consideration of:

- *Type of gutter (external, internal, valley, or roof gutter),,*
- *rainfall intensity,*
- *catchment area,*
- *gutter fall,*
- *gutter-cross-sectional area and wetted surface area, and*
- *outlet and downpipe capacity.*

This section details specific requirements for the sizing of all drainage components.

5.3.1 Catchment Area

The effective catchment area for a gutter is determined not only by the plane area of the roof itself but also by the walls adjacent to the roof. When a wall is discharging on to a roof, half the surface area of that wall (up to a maximum height of 10 m), must be added to the catchment calculation.

5.3.1.1 Roof Pitch

The COP calculations are based on the **plane area** of the roof (which is the sloping surface area of the roof), not the **plan area** (which is the area covered by the roof).

5.3.1.1A Plane Area v.s. Plan Area

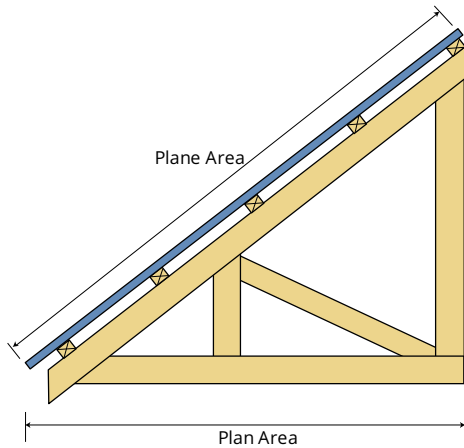

Wind action can influence effective catchment area, and the COP assumes the worst case scenario, i.e., rain striking the roof at an angle perpendicular to the roof plane.

5.3.2 Rainfall Intensity

Rainfall intensity can be taken off the maps for 50-year average return intervals (ARI). When the co-ordinates of a site are known, site-specific values can be obtained using NIWA's HIRDS tool at <https://hirds.niwa.co.nz/>

As NZBC E1 requires that rainwater from events having 2% likelihood of occurring annually shall not enter buildings, the COP uses figures for 50-year Average Return Interval, rather than the 10% probability figures published in E1/AS1.

5.3.2A Comparison of 10-year and 50-year Rainfall Intensities

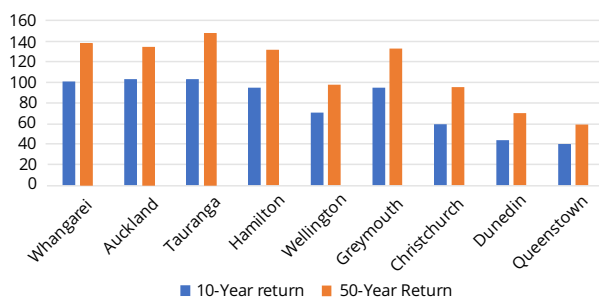

5.3.2B North Island 10 Minute Rainfall Intensity Map: 50 Year ARI

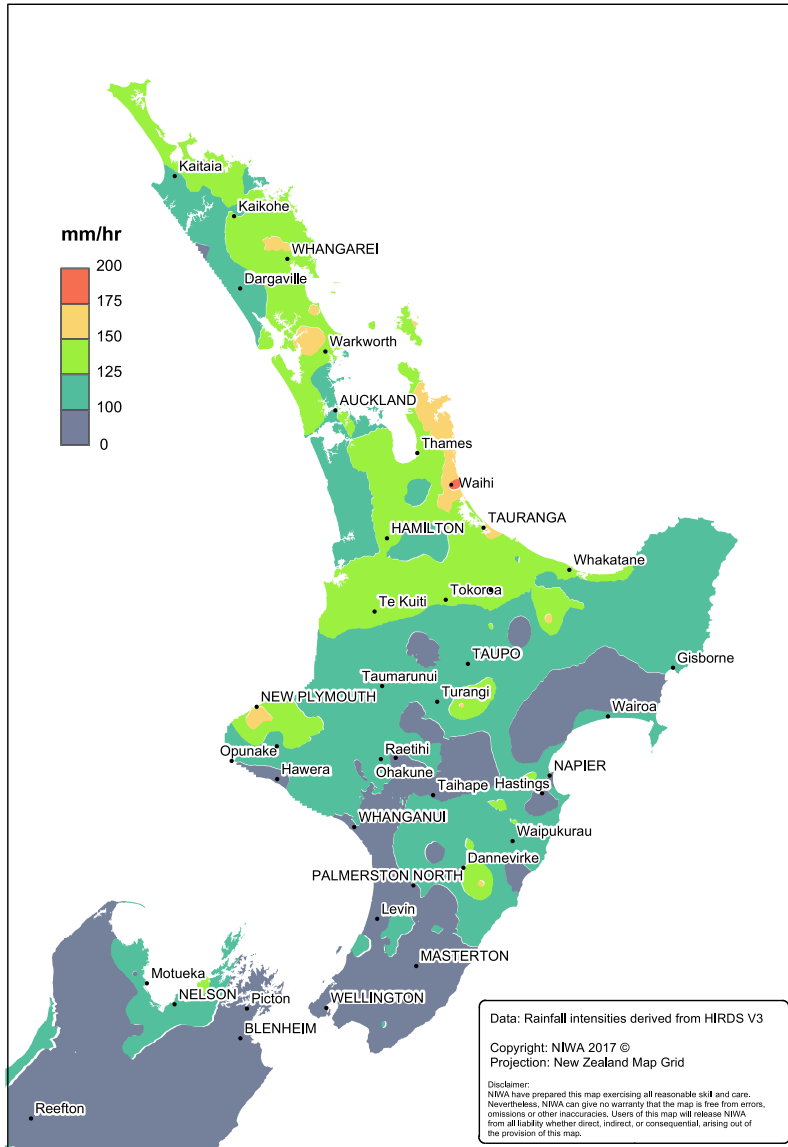

5.3.2C South Island 10 Minute Duration Rainfall Intensity: 50-year ARI

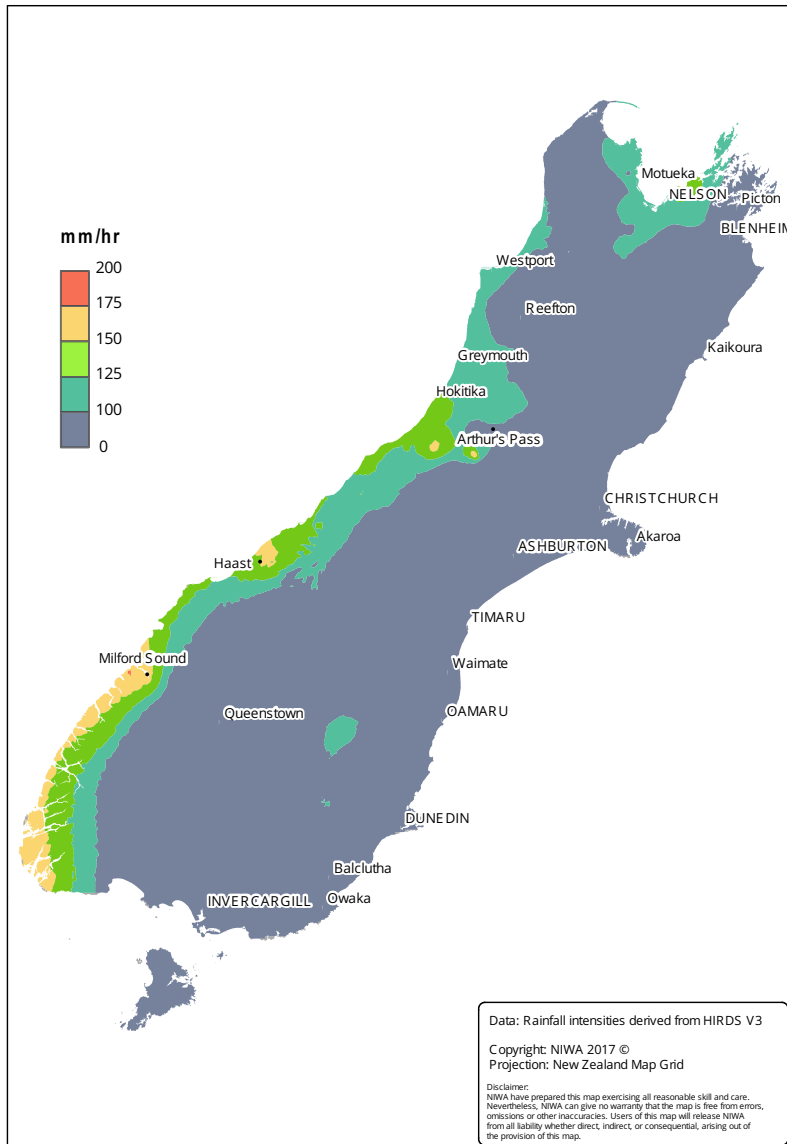

5.3.2.1 Designing for Climate Change

Use NIWA's HIRDS tool for the most accurate rain intensity figures. The HIRDS tool shows figures for historical rainfall intensities and predicted rainfall based on the anticipated effects of climate change, expressed as Representative Concentration Pathways (RCP) levels.

The increased rainfall intensity in a worst-case scenario is typically 11 – 13% higher than historical levels, mostly occurring under the least intense (RCP 2.6) value. To ensure design calculations account for expected climate change, use the most appropriate RCP level.

5.3.2.1A RCP Level Descriptions

Rating Description

RCP 2.6	A very stringent pathway that assumes CO2 levels peak at 2020 and go to zero by 2100.
RCP4.5	An intermediate scenario where CO2 levels peak by 2040, then decline due to the decreased availability of fossil fuels.
RCP 6.0	A stabilisation scenario, where CO2 emissions peak around 2080, then decline with the deployment of various technologies and strategies.
RCP 8.5	Worst-Case scenario where CO2 emissions continue to rise throughout the 21st century. Thought by some to be based on an overestimation of projected coal outputs.

5.3.2.1B Example of RCP Values for Randomly Selected Locations

Location	Historic	RCP				RCP % change
		2.6	4.5	6.0	8.5	
Whangarei	137	147	150	149	152	11
Auckland Central	121	131	133	132	135	12
Mt Maunganui	149	161	164	163	167	12
Waikanae	107	116	118	117	120	12
Christchurch	55	59	60	60	61	11
Dunedin	71	77	79	78	80	13
Queenstown	55	59	60	60	61	11
Huntly	126	136	138	137	140	11
Nelson	114	124	126	125	128	12
Silverdale	124	134	136	135	138	11

Visit NIWA HIRDS-tool to get the corresponding values for specific locations.

5.3.2.1C Example of increasing ARI figures Using RCP Values from Random Locations

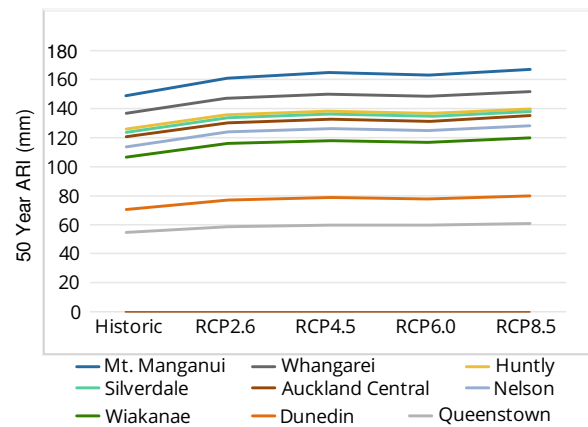

Visit NIWA HIRDS-tool to get the corresponding values for specific locations.

5.3.2.2 Duration

Rainfall intensity figures quoted on the NIWA site are for maximum intensity over a ten-minute duration. Intensity may vary within this period, and roof drains can overflow quickly when demand exceeds capacity. A 1-minute rainfall intensity can be as much as 4.2 times higher than the 10-minute intensity.

To account for short-term rainfall intensity, various factors should be applied to internal and external gutters, and to drains depending on their location and consequence of overflow. See [5.3.2.3A Short-Term Intensity Multiplication Factors](#).

5.3.2.2A Comparison of 10-Minute Published Intensity with 1-Minute and 2-Minute Intensities

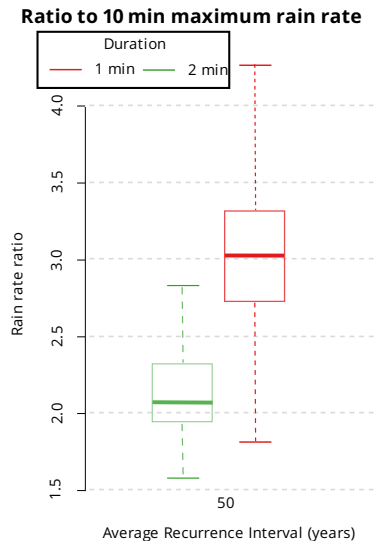

5.3.2.3 Allowance for Short-Term Intensities

The COP drainage calculator multiplies the ten-minute maximum intensity by a factor to allow for short-term fluctuations. This minimum factor varies by gutter location as follows.

5.3.2.3A Short-Term Intensity Multiplication Factors

Application	Gutter Multiplier	Downpipe Multiplier	
		With Overflow	No Overflow
Valleys	3.1	n/a	n/a
Penetrations	3.1	n/a	n/a
Internal Gutters Residential	3.1	2.1	3.1
Internal Gutters Commercial	2.2	1.5	2.5
External Gutters – no Overflow	2.5	1.7	2.5
External Gutters – with Overflow	1	1	1

5.3.2.3B Short-term Intensity Factor Explanation

These are minimum factors; higher factors may be applied at the designer's discretion.

- Valleys, Penetrations, and Internal Gutters Residential have a minimum factor of 3.1 because failure of these gutters is likely to cause damage to internal elements. Where a 2% probability of flooding is unacceptable, a higher figure should be used.
- Internal Gutters Commercial have a minimum factor of 2.2 as failure of these gutters is less likely to cause severe damage and water run time may be longer. Short runs and steep pitches will reduce run time. (At 250 mm/hr intensity and 3 degrees pitch, rain will take 2 minutes to travel 15 metres). For short runs, steeper pitches and where the probability of flooding of 2% is unacceptable, a higher figure should be used.
- External gutters no overflow have a minimum factor of 2.5, providing the building has a soffit. Otherwise, they should be treated as an internal gutter.
- External Gutters with overflow have a minimum factor of 1, provided the building has a soffit, as occasional overflow is not likely to cause damage. To qualify as drained, the back of the gutter must be below the fascia height and it must have a gap of at least 3 mm between the gutter and the fascia or cladding. This gap must be maintained in all areas, including internal angles. External gutters to buildings without soffit must be provided with a 10 mm drainage gap or be designed as an internal gutter.

For convenience, ARI maps are included in the calculation section which includes tables for gutter and valley capacity for different rainfall intensities.

5.3.3 Minimum Freeboard Values

In gutters where overflow can enter the structure, it is necessary to have freeboard to allow for wave action, obstructions, and other unforeseen circumstances. [5.4.7 Gutter Capacity Calculator](#) allow for these minimum freeboard values.

5.3.3A Minimum Freeboard Values

Gutter Type	Freeboard
Internal gutters	30 mm
Secret gutters	15 mm
Valleys > 8°	15 mm
Valleys < 8°	20 mm
Asymmetrical valleys	20 mm
External Gutters with Overflow	No freeboard required
External gutters with no overflow	15 mm

5.4 Gutters

The term “gutters” can be applied to all roof drains, but “spouting” refers specifically to external gutters.

Types of gutter:

- **External gutters** – positioned outside the building envelope.
- **Concealed Fascia-Gutter Systems** – gutters installed directly behind a fascia.
- **Internal Gutters** – formed inside a parapet wall or where two connected gables meet at an internal draining point.
- **Valleys** – where two roof planes meet at an angle of less than 180°.
- **Roof Gutters** – where a penetration obstructs and concentrates the flow of water, often into a single pan.
- **Secret Gutters** – where a roof discharges into a raked barge.

The definition of gutters in the COP includes the troughs of a profile adjacent to an obstruction (such as a penetration) or where a secret gutter is required, i.e., at the barge line of a swiss gable roof.

5.4.1 External Gutters (Spouting)

NZBC clause B2/AS1 requires spouting to have a durability of 5 years. In practice, this is rarely commercially acceptable. However, with sound design and reasonable maintenance, a spouting life of 10 years or more is usually achieved when using the same material as the profiled metal roof.

Spouting that is difficult to access for replacement should be specified in more durable, compatible materials.

5.4.1.1 Bay Windows

E1/AS1 does not prescribe a need for a building to have spouting, it merely requires that concentrations of water gathered by structures does not enter the building or cause damage or nuisance to other property. This is traditionally achieved by using gutters and downpipes to discharge roof catchments into stormwater drains.

Minor wall projections such as bay windows and boxed penetrations are treated as part of the wall catchment and are typically excused from requiring spouting and downpipe, provided the plan view surface area of individual projections does not exceed 5 m².

5.4.1.2 Outbuildings

Small outbuildings such as garden sheds up to 10 m² are also traditionally exempted from requiring spouting and downpipes providing the discharge does not interfere with neighbouring buildings.

5.4.2 Gutter Capacity Design

Spouting should be installed with the back lower than the fascia board or cladding to allow for draining of overflow water through the gap between the gutter back and the fascia.

A 2 mm gap between the back of the gutter and the fascia will give a discharge area equal to the diameter of a

75 mm downpipe for every 2.2 m of gutter run.

This gap is only totally effective if the spouting is correctly maintained and the gap is free of debris. A designed outlet is preferred, either a gutter bracket creating a minimum 6 mm space stop end, a weir, a raised outlet above the spouting sole, a slotted front, or a low fronted gutter.

A weir stop-end, or an outlet with a top edge above the sole of the gutter, can be used to increase outlet capacity.

5.4.2.1 Gutter Fall

All gutters must have a minimum fall of 1:500 (2 mm in 1 m), the COP recommends 1:200 (5 mm in 1 m), as it will improve drainage and self-cleaning.

5.4.2.1A Effect of Gutter Fall on Drainage Capacity

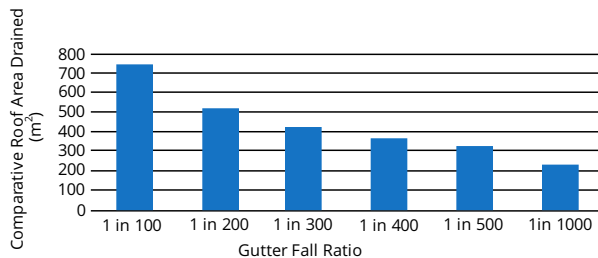

5.4.2.2 Maximum Gutter Length

All gutters are subject to expansion. Maximum gutter-length is determined by the type of metal and its colour. Where gutters have an allowance for expansion (such as an external gutter on a typical gutter bracket or an internal gutter with sliding clips), lengths should be restricted to 25 m in steel and 12 m for copper or aluminium.

An expansion joint can be either a sump, rainwater head or a saddle flashing. Gutters that are directly through-fastened to the fascia or eaves purlin will not be free to move and should be restricted to a maximum of 12 m. Through-fastened gutters are not recommended as they are difficult to replace.

5.4.2.3 Gutter Support Systems

The spouting bracket system must withstand the potential weight of a gutter full of water. In snow load areas, spouting may be fitted with snow straps and brackets at a maximum of 600 mm centres to withstand the additional potential weight of any snow build-up.

Brackets should be made using compatible material or non-ferrous metal. Brackets for pre-painted external gutters should be painted or powder coated before installation.

Brackets for external gutters should be located close to all stop-ends, at both ends of sumps and rain-heads at a maximum of 750 mm spacing for gutters less than 180 mm wide, and at 600 mm for gutters 180 – 300 mm wide. Brackets must be installed to provide a 1:500 (2 mm per metre) minimum gutter gradient towards the outlets.

5.4.3 Internal Corners

When the back of a gutter is cut down to allow the valley to discharge into it, the gutter capacity is affected. In these cases, gutter calculations should allow for 20 mm less water height, and a min 3 mm spacer should be attached to the back of the gutter (or fascia) at the internal corner to maintain the clearance between the gutter and the fascia.

5.4.4 Concealed Fascia Gutters

Concealed gutter systems are bespoke or proprietary systems that run inside the fascia.

The concealed gutter design must ensure that water cannot enter the soffit or overflow into the building if the gutter system outlet becomes blocked.

Overflows must be provided for concealed gutter systems within 1 m on either side of the downpipe to discharge through the soffit, immediately behind the fascia, and be capable of discharging the total catchment area served by the downpipe.

See [5.6.3 Overflows](#).

5.4.5 Internal Gutters

When internal gutters are difficult to replace and their failure could cause major disruption to the building below, they must be made from materials that will last 50 years to comply with the NZBC; metallic coated steel is not recommended for internal gutters that are difficult to replace.

Common internal gutter materials are butyl or other membranes, fibreglass, or non-ferrous metal. Where butyl gutters are used, the metal and flashings should be separated from wet contact with the butyl rubber.

5.4.5A Separation of Butyl Gutter and Metal Roofing

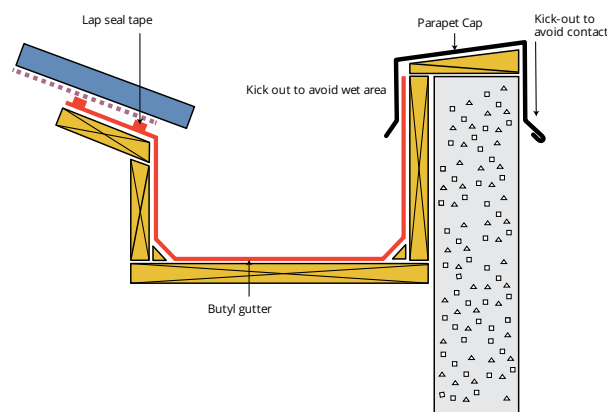

Suitable non-ferrous metals include 0.9 mm aluminium, 0.6 mm stainless steel, and 0.6 mm copper. Contact between coated metal products and copper or stainless steel must be avoided because it will lead to early corrosion. Splashback or runoff from copper onto coated metal can have the same effect.

5.4.5.1 Internal Gutter Design Features

All internal gutters must have upstands that are hooked or returned. Gutters that return under the eaves are not recommended as this design makes removal for replacement more difficult.

5.4.5.1A Hooks and Returns



To prevent permanent deflection of the gutter, support for the sole of an internal gutter should be provided by either a plywood lining or by close ribbed sheets of roof cladding, separated by a layer of roofing underlay. Internal gutter support must be strong enough to support the weight of water when at capacity, and if over 300 mm wide, be able to support foot traffic.

Internal box gutters must have a minimum depth of 50 mm at their lowest point, including freeboard. A width to height ratio of 2:1 plus freeboard gives maximum flow as it minimises wet surface area for a given cross-sectional area.

A sharp direction change in flow of an internal gutter will affect discharge capacity. Where two buildings meet at an angle, each gutter must be drained separately, or a specific discharge capacity calculation must be applied.

Internal gutters should have an expansion joint at the stop-end.

Outflows from internal gutters may be scuppers or weirs.

5.4.5.1B Scupper

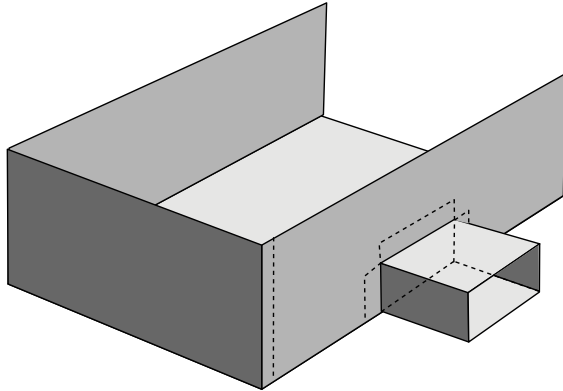

5.4.5.1C Weir

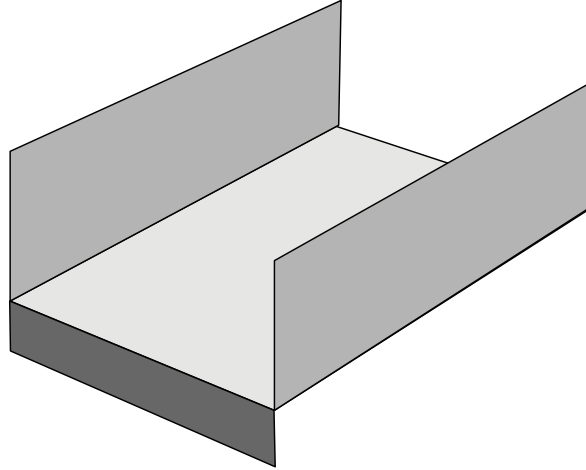

A scupper is formed where an internal gutter discharges horizontally through the side or end wall of a gutter through a restricted opening. If a scupper is the same dimension as the gutter, standard calculations for internal gutter sizing may be used. A scupper in the side of a gutter counts as a right-angle bend when using the Gutter Drainage Calculator. When scuppers have a restricted opening, the size of the opening, not the size of the gutter, determines the effective size of the gutter and its maximum catchment capacity. Scupper apertures are vulnerable to blockage and it is recommended that they are fitted with an overflow to alert the building inhabitants of a problem.

5.4.6 Secret Gutters

A secret gutter is used where the roof edge runs at an angle of less than 90° to a wall, barge, or parapet.

5.4.6A Secret Gutters Behind Barge

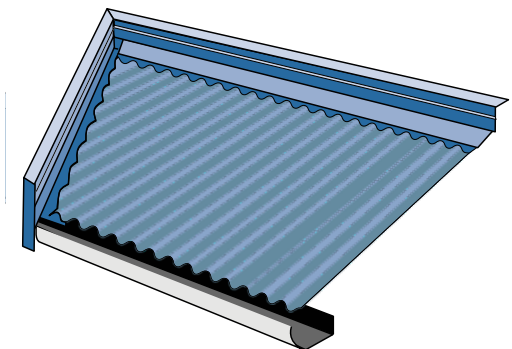

5.4.6B Secret Gutter Detail

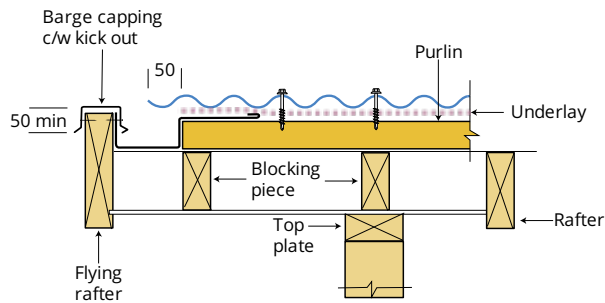

Secret gutters should be wide enough to allow for cleaning and must be designed in accordance with [5.4.5.1 Internal Gutter Design Features](#).

5.4.7 Gutter Capacity Calculator

A responsive online tool for calculating gutter capacity is available at www.metalroofing.org.nz/cop/capacity-calculations.

5.5 Valleys

A valley is a gutter at the internal intersection of two sloping panes of roof cladding.

5.5.1 Valley Fixing

Valleys should not be positively fixed, except at the head, because that would inhibit expansion and can produce noise.

Alternative means of securing the valley gutter to the substrate include:

- A clip system allows for thermal movement and security.
- A compatible washered nail or screw or a galvanised nail, provided they do not penetrate the sole of the gutter.

5.5.1A Valley Clip System

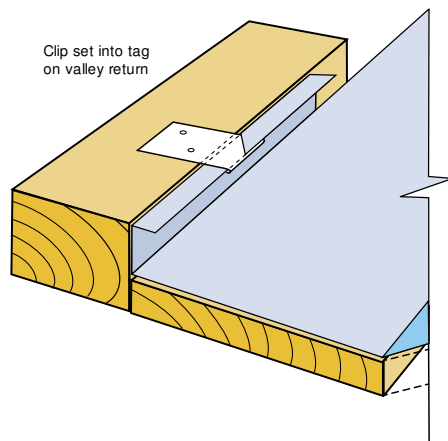

5.5.2 Valley Design

Valley gutters must discharge into a rainwater head, sump, or an eaves gutter. The discharge point must be within 2 m of a downpipe if the catchment area exceeds 50 m².

When the roof pitch is less than 12°, the valley should be made in one piece or the joints must be sealed. To ensure snug fitting, the valley angle should be matched to the pitch of the valley support. Having the valley too open will result in a diminished capacity, and too sharp an angle will make installation difficult.

5.5.2A Common Valley Shapes

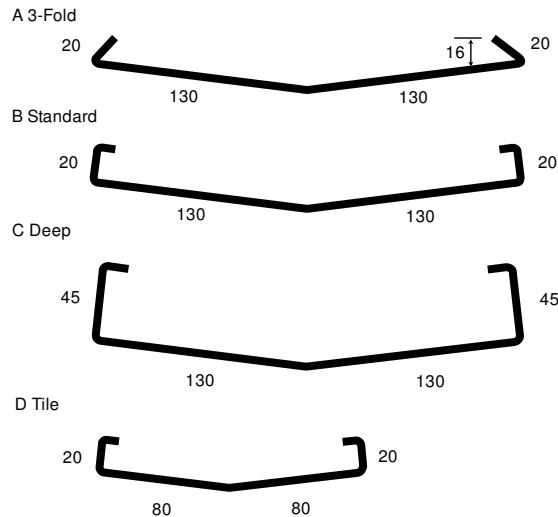

5.5.2B Internal Valley Angle

Roof Pitch	Internal Angle
3°	176°
5°	173°
10°	166°
15°	159°
20°	152°
25°	145°
30°	139°
35°	132°
40°	126°
45°	120°
50°	114°
60°	104°

Roof Pitch	3°	5°	8°	10°	12.5°	15	20°	25°	30°
A 3-fold			12	18	29	41	70	106	146
B standard			25	34	47	63	99	140	184
C Deep	60	86	152	180	215	251	321	389	452
D Tile					17	22	33	45	57

Free Board: 15 mm for pitches 8° and above
20 mm for pitches below 8°

For other pitches, rainfall intensity, and valley shapes refer to the [5.5.7 Valley Capacity Calculator](#) tool.

For information about internal corners, refer to [5.4.3 Internal Corners](#).

5.5.3 Bifurcated Valleys

The maximum recommended catchment area for a bifurcated valley is 10 m².

5.5.3A Ridge Meets a Valley in line with the Valley

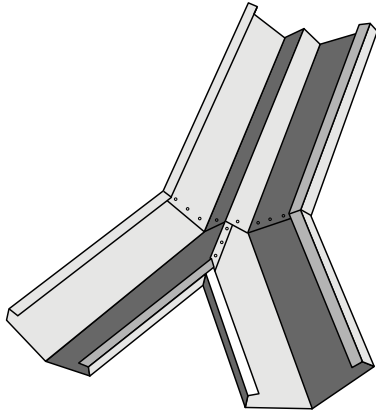

5.5.4 Intersecting Valleys

5.5.4A Correct Valley Intersection

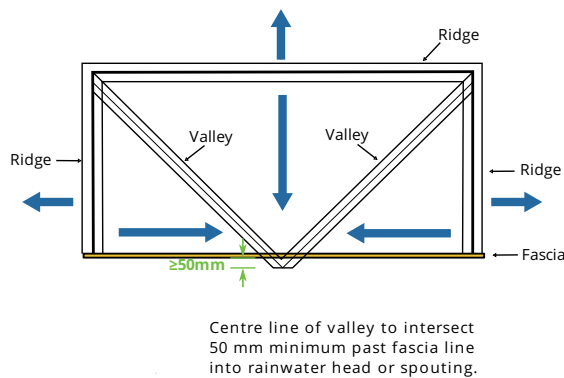

5.5.4B Incorrect Valley Intersection

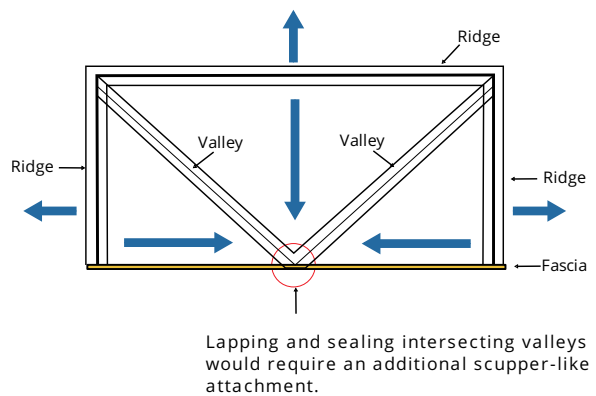

5.5.5 Changing Angles in Valleys

A change of roof pitch in a valley run will usually result in the change of angle in plan view. The change is acceptable, but the freeboard of the lower valley must be at least 20 mm to allow for turbulence.

5.5.6 Asymmetrical Valleys

Where opposing roofs of different pitches discharge into a valley, an asymmetrical valley is required. As these have reduced cross-section area compared to a symmetrical valley at the same (lower) pitch, it is often necessary to increase the valley dimensions. Increasing the depth has the biggest effect on capacity. Greater depth can be gained by using 10 mm ply valley boards, standing purlins on edge, or fitting valley boards flush with the rafter. The consequences that a deeper valley will have on the capacity of the gutter it discharges into must also be considered.

A valley baffle is recommended where the difference in roof pitches exceeds 10°. Valley baffles are also helpful in wooded locations to minimise lodging of debris under the roof overhang.

5.5.6A Valley Baffle

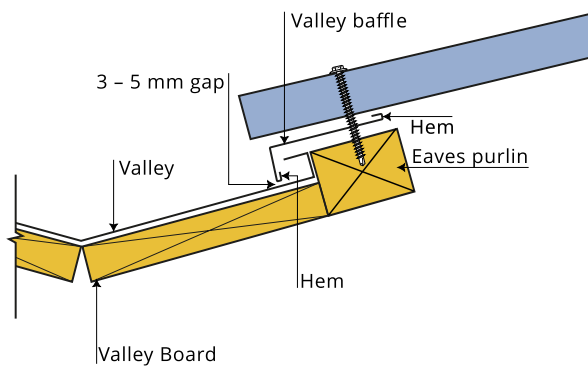

5.5.7 Valley Capacity Calculator

The values for [5.5.2C Maximum Valley Catchment in m² for Areas Having a 50-year Rainfall Intensity <150 mm/h](#) can be found in this PDF document. A responsive online tool for calculating valley capacity is available at [5.5.7 Valley Capacity Calculator](#).

5.6 Rainwater Heads, Sumps, and Overflows

Rainwater heads are situated outside the building envelope and sumps are internally located.

They both serve to increase the head of water entering a downpipe, and to provide an overflow capacity to safely discharge water when downpipe capacity is compromised or exceeded. The overflow should be obvious so discharging water warns the occupant that downpipe capacity has been exceeded or the primary downpipe is blocked.

5.6A Internal Gutter Discharging into a Rainwater Head

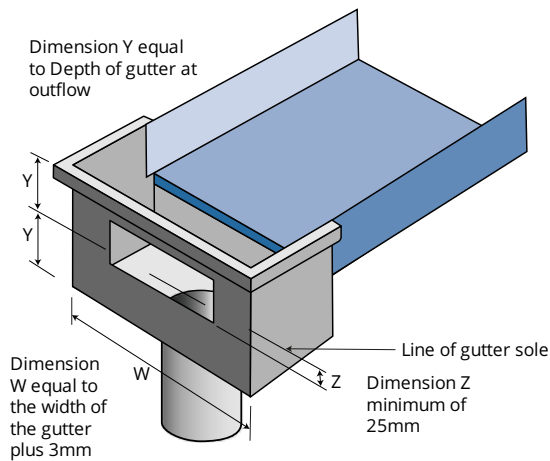

5.6B External Gutter Discharging into a Rainwater Head

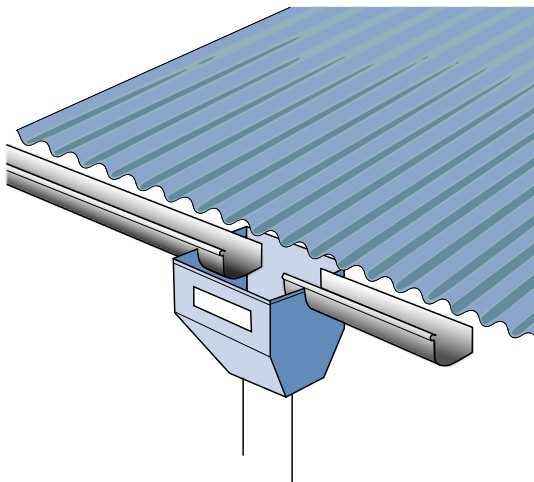

5.6.1 Rainwater Heads

Rainwater heads must be at least as wide as the gutter and have an overflow (normally a weir type). The cross-sectional area of the overflow must be at least equal to that of the required downpipe size for the catchment being served. The lower edge of the overflow must be at least 25 mm below the sole of the gutter, and the upper edge must be at least 25 mm below the upper edge of the gutter.

5.6.2 Sumps

Sumps must be at least the same width as the gutter and have an outlet positioned below the sole of the gutter to increase the head of water at the outlet.

5.6.2A Sump – Same Width as Gutter

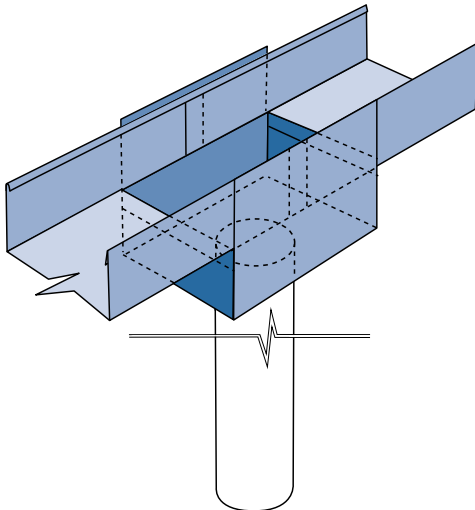

Internal sumps must have overflows. These are often a secondary pipe overflow, with the outlet height positioned above the level of the primary outlet. Internal sumps must also be sealed against the sides and sole of the gutter.

5.6.2B Sump with Obvious Overflow

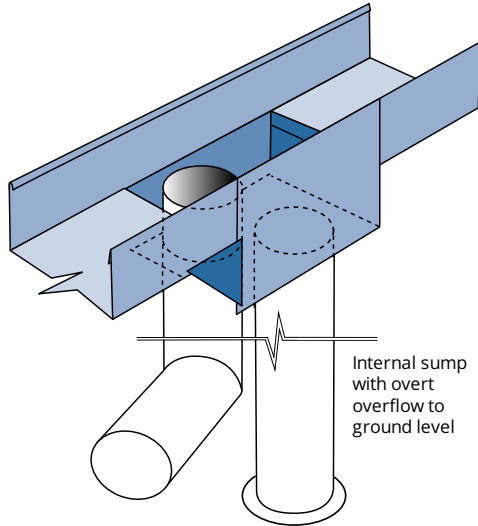

An internal sump should have a guard that prevents debris from blocking the outlet. A removable aluminium expanded-metal box can be fitted at a minimum of 40 mm below the sole of the gutter. Because the top is flat, it is unlikely that the entire surface area of the outlet can become blocked, so it is preferable to balloon-type guards. A leaf guard should have a horizontal surface area of at least four times the size of the downpipe outlet area and should be installed at roughly mid-height of the sump depth. Gratings can cause sump blockage, and this can reduce the outlet capacity.

5.6.2C Sump with a Leaf Guard

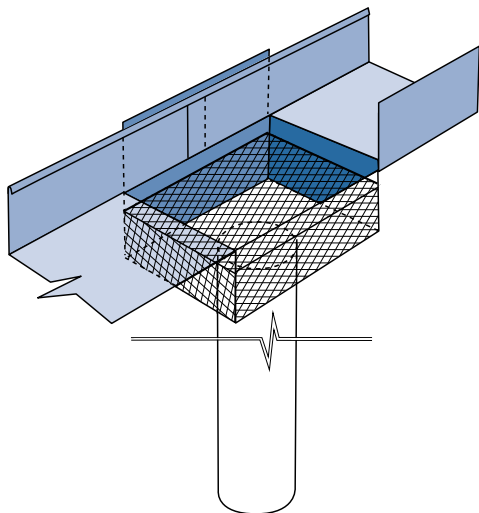

Gratings or guards should be designed so that any debris will float, and hail, or obstructions, such as a tennis ball, will not wedge and block the guard. Gratings or guards should be cleared of accumulated debris regularly as part of normal maintenance.

5.6.3 Overflows

Overflows must discharge clear of the building to clearly show that downpipe capacity has been exceeded; it should be an obvious indication that the gutters need maintenance.

The overflow opening of a rainwater head from an external gutter must have a cross-sectional area equal to that of the downpipe. The bottom of the overflow must be no higher than 25 mm below the bottom of the spouting.

Where the position of an outlet of a parapet wall gutter is on an outside wall, any scupper outflow should discharge into a rainwater head.

5.7 Outlets and Downpipes

A gutter's discharge capacity increases with the depth of water over the outlet. The best way to increase the head is to discharge the open end of the gutter into a rainwater head or sump. Swirl at the outlet reduces its performance, so positioning of the outlet is important.

Outlets must be placed at a distance less than or equal to the outlet diameter from the nearest vertical side of the sump.

Where they are connected directly to the drain, all internal downpipes must be sealed to internal sumps by a compression ring, or similar fitting, and must have access for cleaning at the base. All sump downpipes must be able to withstand a water pressure test with an applied head of 1.5 m of water without leakage.

To avoid any water back-up if the drain capacity is overloaded or obstructed, an air-break should be provided for all downpipes to ensure that water does not back up the downpipe.

All exterior downpipes must discharge freely over a grated gully trap or into an oversize pipe which must be a minimum of 50 mm above the adjacent ground level.

5.7A Downpipe Draining into a Grated Gully Trap

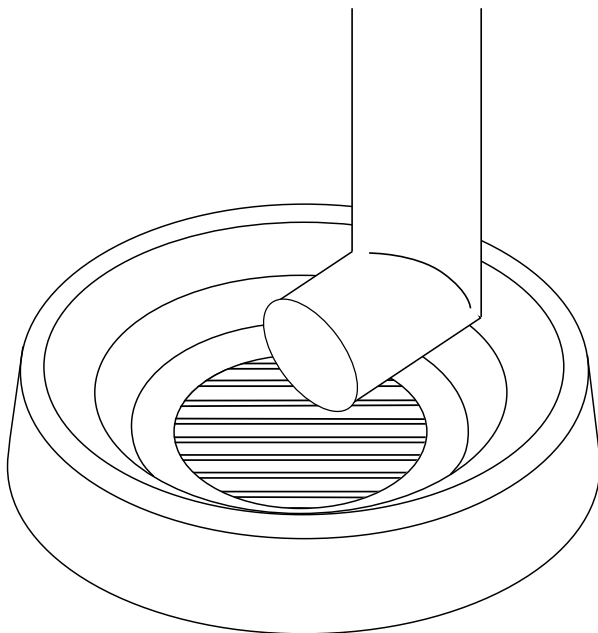

5.7B Downpipe Draining into a an Oversized Pipe

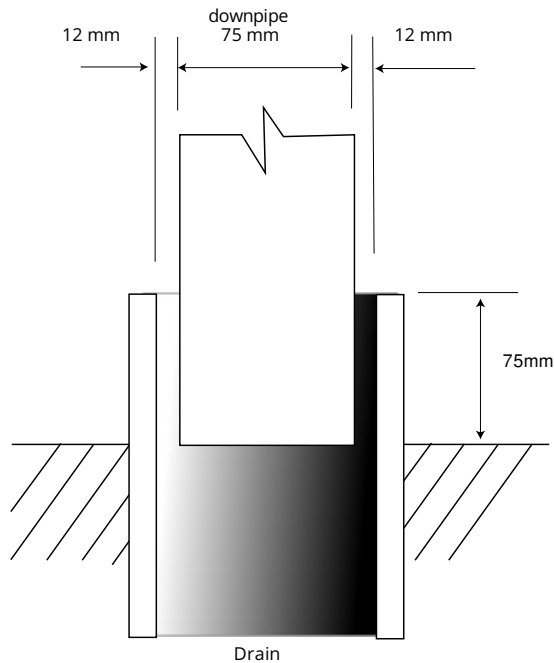

Downpipes fixed at an included angle of less than 105° must have a cross-sectional area equal to that of the gutter or be sized by calculation.

Downpipes must be compatible with the roof and gutter material and must comply with the 15-year durability requirement of the NZBC.

Discharging water off an inert surface onto unpainted galvanised rainwater goods can cause corrosion. See [4.11B Normal Catchment](#).

Horizontally run PVC downpipes and gutters require a greater provision for expansion than metal, particularly if they are painted a dark colour. Horizontally run PVC downpipes and gutters should have a maximum length of 9 m.

When rainwater is collected into a water tank, there is often not enough distance to obtain adequate fall for one downpipe outlet. In such cases, or whenever the roof design pre-empt's a continuous spouting to the tank, it is possible to have several sealed downpipes (some of which can run underground) to discharge into the tank. The outlet discharging into such pipes should be a rainwater head to avoid flooding.

5.7C Collecting Rainwater in Tanks

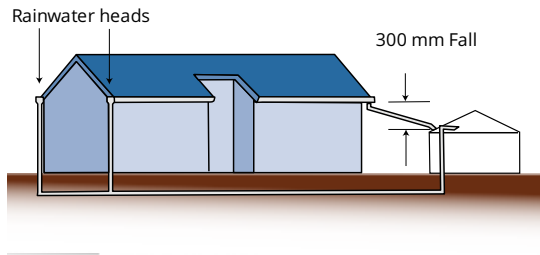

5.7.1 Placement of Downpipes

Placement of downpipes significantly affects gutter and downpipe calculations.

5.7.1A Downpipe Placement

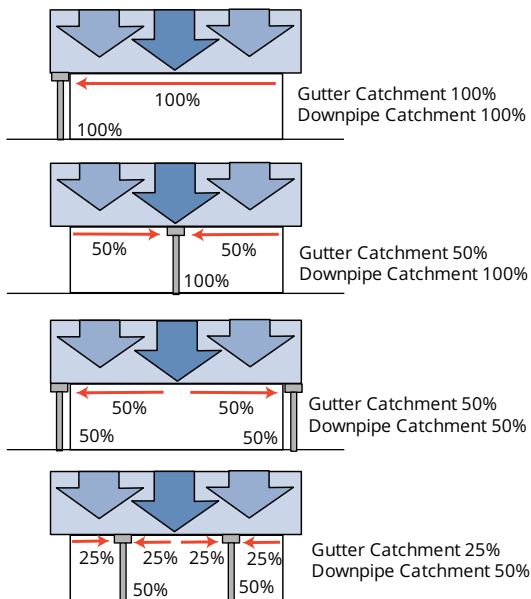

5.7.2 Capacity Table for Common Size Downpipes

Use this table to select the correct internal dimensions of common downpipe sizes for use in the online calculator at [5.4.7 Gutter Capacity Calculator](#).

5.7.2A Downpipe Capacity Table

Material	Size	Nominal Diameter (mm)	Internal Dimension (mm)	x-Section Area (mm ²)
PVC	65 x 50		65 x 52	3380
	100 x 50		102 x 51	5171
		65	63	3138
		80	76	4537
		110	98	7626
		160	143	16157
		200	178	25157
		250	224	39840
		280	253	50823
		315	274	59610
Steel		75	75	4466
		100	100	7940
		90x50	90 x 50	4400

5.7.3 Downpipe Capacity Calculator

The values for [5.7.2 Capacity Table for Common Size Downpipes](#) can be found in this PDF document. A responsive online tool for calculating downpipe capacity available at <https://www.metalroofing.org.nz/downpipe-capacity-calculator>.

5.8 Downpipe Spreaders

All downpipes that discharge onto a lower roof must have a spreader to dissipate energy and ensure wide distribution of the water. A spreader should be used over multiple troughs.

For corrugate, a spreader should not discharge into a lapped trough. When using the COP calculator, discharge may be into a lapped trough of a trapezoidal or a trough profile.

The area of discharge holes from a spreader should equal the cross-sectional area of the downpipe.

The **5.8.1 Maximum Area Above Spreader Calculator** enables users to determine the maximum upper roof area that a lower roof can discharge for a given combination of rainfall intensity, roofing profile, and lower roof pitch.

5.8A Downpipe Spreader design

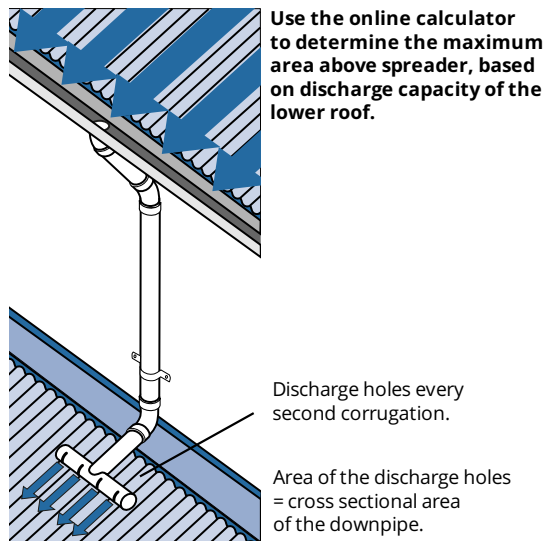

Lower roof drainage capacity determines maximum area above spreader. It is dependent on:

- rainfall intensity,
- lower roof profile,
- lower roof pitch,
- lower roof length,
- downpipe/spreader capacity.

5.8.1 Maximum Area Above Spreader Calculator

Before using this calculator, please read **5.3 Roof Drainage Design**.

Calculate the maximum area above a spreader by entering the values in the designated fields.

For an explanation of each element, please click on the corresponding question mark.

For rainfall intensities, refer to **NIWA's HIRDS tool** or the **5.3.2 Rainfall Intensity**.

A responsive online tool for calculating Maximum Area Above Spreaders is available at

<https://www.metalroofing.org.nz/maximum-area-above-spreader-calculator>.

6

External Moisture Overview

The primary function of a roof is to shed external moisture. The Code of Practice deals with External Moisture in four sections, allowing for more detailed discussion. The solutions in the COP relate to all buildings and are not limited to buildings within the scope of NZS 3604.

Included in the COP under External Moisture:

6 External Moisture Overview provides an extract from NZBC E2 External Moisture. It highlights the Objectives, Functional Requirements, Performance Requirements, and Limits of the NZBC Clause E2. The second half highlights the scope and extent of Acceptable Solution E2/AS1.

7 External Moisture Roofing discusses the external moisture requirements and strategies for dealing with external moisture where it concerns metal roof and wall cladding.

8 External Moisture Flashings discusses strategies of managing external moisture with a specific focus on flashings.

9 External Moisture Penetrations focusses specifically on managing external moisture and preventing leaks around penetrations.

6.1 NZBC Clause E2 External Moisture (Extract)

6.1.1 E2 Objective

The objective of this provision is to safeguard people from illness or injury which could result from external moisture entering the building.

6.1.2 E2 Functional Requirement

Buildings should be constructed to provide adequate resistance to penetration by, and the accumulation of, moisture from the outside.

6.1.3 E2 Performance Requirements

- 1. Roofs shall shed precipitated moisture and snow.*
- 2. Roofs and external walls shall prevent the penetration of water that will cause dampness or damage to the building elements.*

Other performance requirements quoted relate to transmission of ground moisture, areas below suspended floors, condensation in concealed cavities, and construction moisture.

6.2 Compliance

In the context of COP Roof drainage, NZBC E1 requires that water discharging into a gutter must have less than a 2% probability of entering a building. This means that those drainage paths inside the building envelope, including valleys and internal gutters, must be designed to accommodate a 50-year rainfall intensity over a short period. Roof Drainage Design discusses how the COP addresses this in more detail.

The above caveat equally applies to the limitations on run length of roof cladding, drainage capacity around penetrations, and discharge of spreaders, which are dealt with in:

- [7 External Moisture Roofing](#),
- [8 External Moisture Flashings](#), and
- [9 External Moisture Penetrations](#).

Gutter catchments outside the envelope, which can discharge freely without entering the building, can be calculated using less rigorous safety factors

6.3 Related Topics

NZBC E2 – External Moisture is primarily focussed on a buildings' external envelope being able to resist weather infiltration.

Acceptable Solution E2/AS1 also has some information on gutter sizing and durability, but these are also covered in E1 – Surface Water and B2 – Durability.

E2/AS1 also has some prescriptive solutions for structure regarding roofing spans which are omitted from B1 - Structure.

For clarity, this Code of Practice deals with the following topics discretely:

- Resistance to loads in [3 Structure](#).
- Durability covered in [4 Durability](#)
- Gutter design covered in [5 Roof Drainage](#) .
- NZBC E2 Compliance requirements in [6 External Moisture Overview](#) .
- Managing water ingress of metal roof and wall cladding in [7 External Moisture Roofing](#).
- Managing water ingress through flashings in [8 External Moisture Flashings](#).
- Managing weathertightness of penetrations in [9 External Moisture Penetrations](#).
- Managing Internal Moisture is covered in [10 Internal Moisture](#).

7

External Moisture Roofing

This section should be read in conjunction with [6 External Moisture Overview](#).

7.1 Roof Pitch

The pitch is the angle between the horizontal and the roof line. It is also the relationship between the rise and the horizontal span of the roof. See [18.2 Pitch & Rise Calculator](#) for the tabulation of these values and a calculation tool.

7.1.1 Minimum Roof Cladding Pitch

7.1.1A Minimum Pitch for Generic Metal Roofing

Profile	Min Height	Min Pitch	Check Capacity after run of...
Trapezoidal	20	4°	20 m
Asymmetrical	27	3°	40 m
	36	3°	65 m
Trapezoidal	20	4°	15 m
Symmetrical	30	4°	25 m
Secret Fix	30	3°	60 m
	25	3°	30 m
Standing Seam	30	3°	85 m
	25	3°	35 m
Corrugate	16.5	8°	15 m
	21	4°	20 m
	35	3°	65 m

Minimum pitches quoted in this table refer to roof cladding pitch and not the building design roof pitch.

Buildings designed with widely spaced purlins and widely spaced portal frames may require an increased design pitch to comply with the minimum recommended as-laid pitches.

Low pitched roofs require greater attention to flashing details. The ability of side laps or end laps to withstand water penetration also becomes more critical at low pitches, but the good design of flashings can ensure weathertightness in extreme conditions.

Water backup against vertical faces caused by high velocity, localised wind eddies, especially inside parapets and at the bottom edge of walls, are all vulnerable details. Pressure equalisation-designs and wind baffles are more effective in preventing water ingress than increasing the flashing cover width.

7.1.1B Exceptions to the Minimum Recommended Roof Cladding Pitch requirements:

- Curved roofs, where by design the minimum pitch at the crest is always less than the prescribed minimum pitch. In these cases, the pitch at the eaves must comply with the profile's minimum pitch, and the pitch at the upper end of a terminated arc must be a minimum of 3°. (See [15.1 Curved Roofs](#)).
- The back curbs of penetration flashings where the minimum pitch is 1.5°. (See [9 External Moisture Penetrations](#))

7.1.2 Runoff

Runoff is the ability of the roof cladding to discharge maximum rainfall without water penetrating through side laps, end laps or flashings and depends on rainfall, the catchment area, the roof pitch, and the profile geometry.

The roof pitch determines the rate of flow; steep slopes shed water faster than shallow slopes. The rib height and spacing of trapezoidal profiles also affects its shedding ability.

For example: At a rainfall intensity of 200 mm/hour, a five-rib trapezoidal profile at 3°, with a rib height of 27 mm can have a run of 90 m.

The [7.1.4 Maximum Run Calculator](#) can calculate capacities for any known profile.

7.1.3 Roof Drainage Capacity

The capacity of a roof profile to drain water is determined by its geometry and the roof pitch. The catchment area is the distance between rib centres times the length, and the effective cross-section area and the wetted perimeter is taken to the height of the overlap on corrugate, or capillary bead on trapezoidal and trough section profiles.

The [7.1.4 Maximum Run Calculator](#) gives the maximum length that a roof can drain at a given pitch and rainfall intensity. The manufacturer's data can be accessed from the drop-down box; for other profiles, the data can be entered manually into the worksheet.

7.1.3A Trough Capacity



Where the flow of water is concentrated by penetrations or spreaders, go to the [9.4.4 Maximum Area Above Penetration Calculator](#).

7.1.3B Penetration Gutters

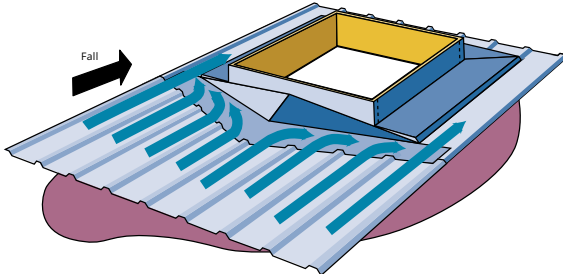

7.1.4 Maximum Run Calculator

More information about [5.3 Roof Drainage Design](#) can be found in this PDF Document. A responsive online tools for calculating maximum run of any given profile, pitch, and rainfall intensity is available at <https://www.metalroofing.org.nz/maximum-run-calculator>.

7.2 Fastening Roofing

All fastenings that pierce the sheeting should be provided with adequate sealing washers to prevent leakage. Sealing washers should be made from Ethylene Propylene Diene Monomer (EPDM).

Fastenings should be tightened only enough to form a weatherproof seal without damaging the sealing washer or deforming the sheet profile. Deformed sheeting will cause water to pond around the seal.

Swarf should be removed from under the sealing washer as it will not only cause staining but also interfere with the seal.

7.3 Thermal Expansion And Contraction

All metal cladding and flashings are subject to expansion and contraction caused by changes in temperature, and their design should allow for this movement. The energy produced should be absorbed without damage to the cladding, fixings or structure. The recommendations in this section are specific to preventing damage and leaks through thermal movement. Thermal movement can also cause disturbing noise levels in dwellings with shorter member lengths than those recommended in this section. (See [12.1 Roof Noise](#).)

The ribs of metal trapezoidal or corrugated roof and wall cladding absorb expansion across the width of the sheets, but special provisions are needed over the sheets' length.

Much of the longitudinal expansion is taken up by the bowing of the sheet between fastened supports. The extent to which this happens depends on the profile strength and support spacings.

Failure by thermal expansion normally results in shearing of the fastener. Fasteners into lightweight steel purlins up to 3 mm in thickness are less vulnerable as they tend to rotate rather than be subjected to repeated bending resulting in fatigue failure. Fasteners into hot rolled steel sections or timber are far more vulnerable to this mode of failure and in all run lengths over 20 metres provision for expansion must be made when fastening into such supports.

Where overlapping sheets are fastened through the ends, they must be considered as one length to calculate thermal movement. Unfastened end laps are not recommended.

Wall cladding does not require the same provisions as roof cladding, because of solar radiation angle.

Oversized holes and washers give some room for expansion and contraction, but it is not enough to allow movement without stress or distortion over long spans. In such cases, a step joint should be used. (See [8.5.4.3B Stepped Roof Flashing](#))

7.3.1 Temperature Range

Ranges of temperature likely to be experienced in NZ by different steel cladding are:

7.3.1A Steel Cladding Temperature Ranges

		<i>Max/Min Roof Temp °C</i>	<i>No Wind</i>
<i>Insulated</i>	<i>Light colour</i>	<i>+60° -15°</i>	<i>= 75°</i>
<i>Insulated</i>	<i>Dark colour</i>	<i>+80° -15°</i>	<i>= 95°</i>
<i>Uninsulated</i>	<i>Light colour</i>	<i>+50° -10°</i>	<i>= 60°</i>
<i>Uninsulated</i>	<i>Dark colour</i>	<i>+65° -10°</i>	<i>= 75°</i>

Aluminium and zinc, which have twice the expansion rate of steel, do not necessarily expand to this degree because of the different characteristics of mass, emittance, and radiance which affects their temperature range. Copper expands one and a half times as much as steel, and stainless steel can expand up to 1.5 times as much as steel depending on composition.

The theoretical expansion of steel roof cladding in mm is 12 x temperature change x length in metres/1000.

Steel expansion rates can be calculated as follows:

Given a length (e.g., 30 m) and that the material (e.g., a light-coloured uninsulated roof) moves through a 60°C range (e.g., + 50°C -10°C), the theoretical increase in length is 12 x 60 x 30/1000 = 21.6 mm.

This amount of movement of roof cladding and components does not have to be provided for in practice, because:

- *The building also expands with the ambient temperature, although to a lesser degree.*
- *Fasteners into light gauge purlins will roll rather than bend. The purlin flange may also roll to a degree.*
- *The roof cladding bows between purlins when it is constrained. Sighting down a corrugated steel roof on a warm sunny day will show an undulating line compared to a straight line when the roof is cool. The forces created by expansion and contraction are self-levelling, i.e., each component moves under load until the resisting force is more than the expansion force.*
- *When a length of sheeting is solid fastened at the centre and unconstrained at either end, the movement is towards the ends of the sheeting; meaning the actual expansion or contraction movement is only half that of a full length of roof or wall cladding fastened at one end. Special design of the ridge or head barge flashing is required in these cases to allow free movement. Alternatively, sheets can be solidly fixed at the upper region, so all expansion takes place in the lower part of the sheet towards the eaves.*

7.3.2 Roof Cladding Expansion Provisions

The expansion of roof cladding depends on the materials, the constraints imposed by the fixing, the heat paths in the building and the actual temperature. The following graphics are indicative of favourable and unfavourable conditions for thermal expansion and suggest what these are. They show the lengths under both sets of conditions above which special provision needs to be made to accommodate thermal expansion.

7.3.2A Favourable Circumstances for Controlling Expansion

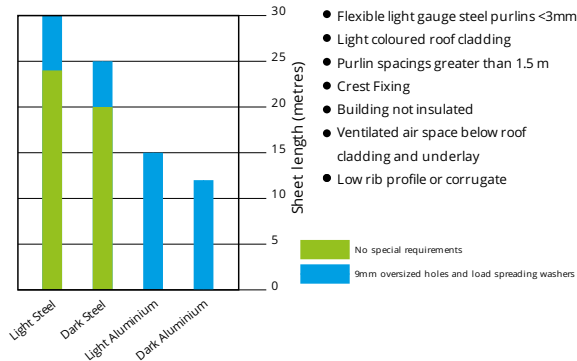

7.3.2B Unfavourable Circumstances for Controlling Expansion

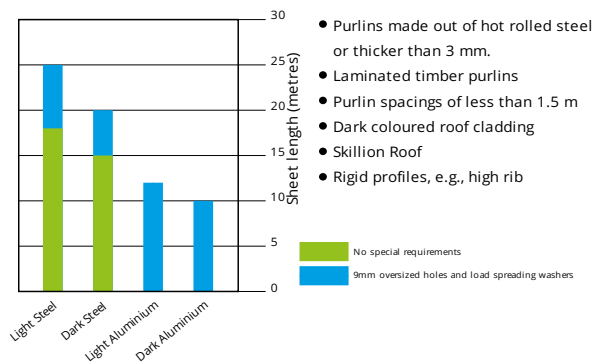

Notes:

1. Where a roof requires oversize holes, only the portion of the roof outside of the recommendations require provision for expansion. Normally this takes place towards the eaves
2. These are guidelines only and special engineering of the roof, fixing or ventilation may allow greater spans to be used.
3. These diagrams refer only to roof cladding screwed through the top. Secret or clip fixed roofs can move more freely if installed correctly and allow for using greater run lengths.
4. The recommendations are based on preventing damage to the fasteners and are not a recommendation to prevent roof noise.

7.4 End Laps

End laps should be avoided if possible when installing metal roof cladding as an incorrectly sealed end lap may entrap water and cause corrosion. When the sheets are too long to be transported or exceed the longest recommended length (see [7.3.2 Roof Cladding Expansion Provisions](#)), the transverse or end lap joint can be avoided by using a waterfall step. (See [8.5.4.3A Step Apron Details](#))

When long lengths outside the capacity of available transport are required, secret-fixed roof cladding can be supplied by using an onsite roll-forming machine.

Where end laps are unavoidable, a sealed joint should be made using sealant at both ends of the lap. The upper seal is critical as condensation entering the upper side of the lap from underneath can cause rapid corrosion. (See [14.12.1 Sealing End Laps](#).) Rivets are used to fix the sheets together and should not be fastened to the purlin. The sheets are fixed to the purlin using screw fixings.

The two lengths should be regarded as one length for expansion provisions.

8

External Moisture Flashings

This section should be read in conjunction with [6 External Moisture Overview](#) and [9 External Moisture Penetrations](#).

The purpose of a flashing is to divert water away from any point of entry and to make a building weatherproof.

Flashings are not only required to weather the many junctions on a roof or wall structure but are often a highly visible part of the roof and wall cladding design. Therefore, they perform an important role in the aesthetic appearance of the building.

It takes longer to make and install flashings than fixing roof or wall cladding, so designers should be aware of the cost effects of design complexity.

8.1 Flashing Materials

Exposed flashings are typically manufactured using the same base metal material as used for the roof and wall cladding. If flashings are required to match the colour of the profiled cladding, it is necessary for the pre-painted flat sheet or coil to be made by the same manufacturer, using the same process. When it is not possible, or if different materials are intended or specified, the alternative materials should be compatible considering both contact and runoff. (See [4.9.4 Compatibility Table](#))

All flashings must be fabricated from a ductile material and designed for lateral strength by folding, stiffening, or ribbing on external edges, with a maximum unstiffened width of 300 mm.

Vertical faces of flashings such as barges and fascia can exhibit oil canning. This can be minimised by using heavier gauge material, by forming stiffeners, or by providing clip fastened attachment systems which allow for thermal movement. In critical visual areas, the COP recommends a maximum unstiffened depth of 200 mm on the vertical face.

Metal flashings must have a bend radius complying with the minimum radii prescribed in [4.10.8 Microcracking](#).

The minimum thickness for metal flashings must be:

- Coated steel — 0.55 mm,
- Aluminium — 0.70 mm,
- Copper — 0.60 mm,
- Zinc — 0.70 mm,
- Stainless steel — 0.45 mm.

Proprietary EPDM penetration flashings are detailed in [9.5 Boot Flashings](#).

8.1.1 Flashing Durability

Where a flashing is hidden or is otherwise difficult to access for maintenance or replacement, or it requires cladding to be removed to replace the flashing, it must have durability for the life of the building or not less than 50 years. All flashings should be made from materials with a durability expectation not less than that of the cladding.

In some corrosive environments, stainless steel or non-ferrous metals should be used for flashings. All metals must be checked for compatibility with the roof material. (See [4.9 Compatibility](#) and [4.9.4A Interactive Material Compatibility Tool](#))

8.2 Flashing Design

Transverse flashings run across the roof slope at right angles to the ribs of the roof and longitudinal flashings run down the roof slope.

Ingress of rain into the roof or wall cavity via the flashings can be caused by the pressure differential between the air outside and that inside the roof or wall cavity. The pressure differential caused by wind gusting fluctuates greatly, so a gap should be created behind the outer edge of a flashing to provide a pressure cushion.

Longitudinal flashings are best designed with a pressure equalisation gap to balance varying pressures and prevent capillary action. (See [4.10.6 Capillary Action](#).)

The preferred maximum production length of flashing is 6–8 m, depending on profile strength. As any sealed lap secured by rivets or screws effectively becomes one length, provide expansion joints where required. Flashings are similarly restricted in length as roof and wall cladding sheets and are subject to the same requirements and expansion provisions. (See [7.3.2 Roof Cladding Expansion Provisions](#).) Inadequate provision for flashing expansion can also cause roof noise

Avoid wet contact between the edges of flashings and concrete, plaster or butyl rubber (See [4.9 Compatibility](#).) When notched flashings are used, the cut edge must not touch the pan, as that can cause corrosion from abrasion.

8.2A Notched Flashing

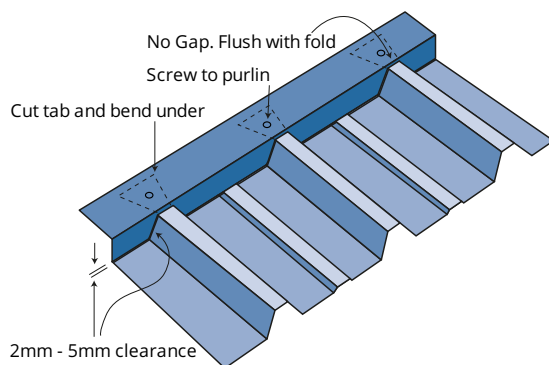

8.2.1 Flashing Edges

The dressed soft edging or the downturn of a notched flashing acts as a baffle to wind and rain at the outside edge of a transverse flashing, as does the stop-end of the cladding at the upper end. The void in between these two barriers acts as a pressure equalisation gap.

Soft edging can be supplied in material compatible with the roofing material. This may be a naturally malleable metal, or metal perforated to enable it to be shaped to the profile, see [17.3 MRM Soft Edge Standard](#).

Stop ends must be provided for all pitches in all wind zones

In extreme circumstances, a profiled or notched closure can be used between the stop end and the downturn or soft edge. When closures or filler blocks are used, they must be adhered to the profile or secured by the cladding fasteners to ensure they remain in position.

Additional ventilation requirements must be considered when using profiled closures, see [10.10 Ventilation Pathways](#).

8.2.1A Hemmed Flashing

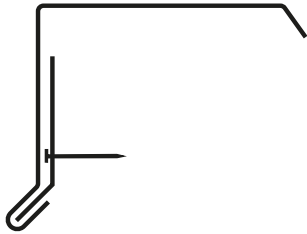

8.2.1B Kick-out Flashing

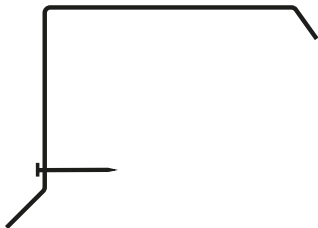

8.2.1C Bird's Beak Flashing

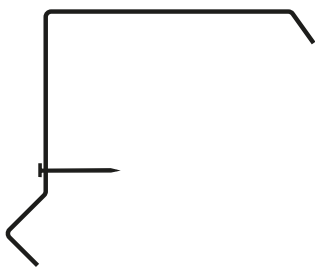

8.2.1D Notched Flashing Edge

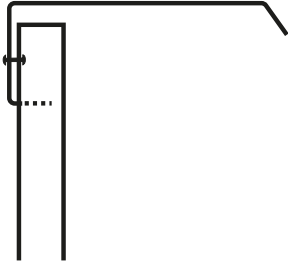

8.2.1E Boxed Flashing

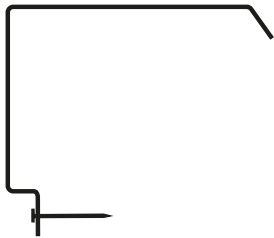

8.2.1F Kick-in Flashing



8.2.1G Flashing Hook



Anti-capillary hems must be flattened parallel but not completely crushed.

8.2.1H Flashing Hem or Crush Fold



8.3 Metal Fascias and Facades

Where the vertical planes of metal facings are exposed to sight, they should be designed to allow movement and minimise thermal buckling, and buckling from timber shrinkage. Maximum dimension between folds should be restricted to 300 mm where possible, or swages installed to stiffen the panel. Constructing such flashings from thicker material will also help prevent distortion, but availability of such may be subject to minimum order quantities. Edges should be clip-fastened to allow thermal movement, and lengths over 6 m should be installed with a thermal expansion joint. This can be constructed as an overlap, or a negative detail with sheet ends overlapping an under-soaker, with a gap between the ends of the exposed faces. Typically, this gap would be 5 mm for steel flashings, and 10 mm for aluminium. [8.5.3 Parapet Cappings](#) shows an example of a parapet cap expansion detail.

8.3A Buckling in Metal Fascia Due to Thermal Expansion



8.4 Flashing Cover

The weathertightness of a flashing is determined by the flashing cover (C), not the flashing dimension.(D) Other considerations are catchment area, wind exposure, roof pitch and profile height.

8.4A Flashing Dimension 'D' and Cover 'C'

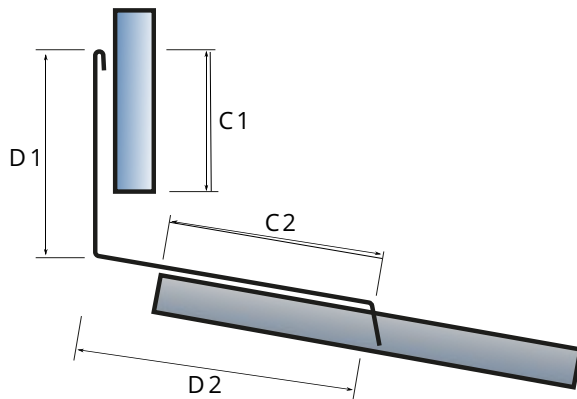

The minimum flashing cover (C) must correlate with the tables below.

There are three categories of exposure or pitch that determine the required flashing cover .

Category A:

- Low, Medium or High Wind Zones, all pitches
- Very High and Extra High Wind Zones where the pitch is equal to or greater than 10°.

Category B:

- Very High where the pitch is less than 8°, and
- Extra High Wind Zones all pitches.

Category C:

- SED Wind Zones up to 60 m/s all pitches.

8.4B Minimum Flashing Cover

NOTE: These tables are relevant to trapezoidal profiles with a rib height of 25 – 34 mm and standard corrugate. Longitudinal Apron flashings over profiles with a rib height greater than 34 mm may have one rib overlap

8.4C Ridge and Head Flashing Cover

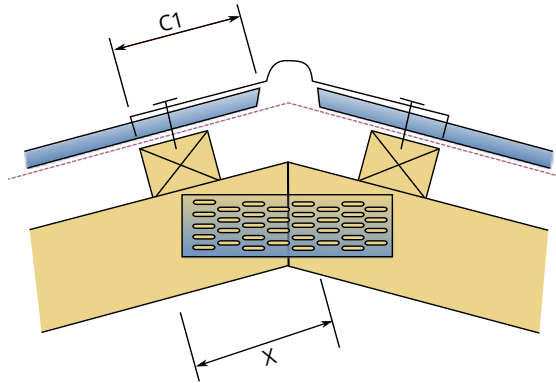

8.4D

Dimension	Category		
	A	B	C
C1	130 mm	200 mm	200 mm + baffle
Ridge Type	Standard	Wide	Wide
Purlin Position X			
Pitch 8°–15°	165 mm	150 mm	150 mm
Pitch 15°–30°	150 mm	200 mm	200 mm
Pitch 30°–45°	130 mm	180 mm	180 mm

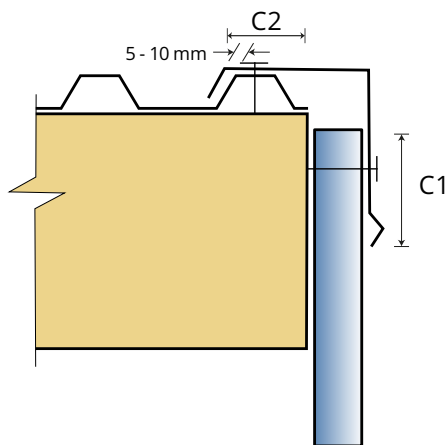
8.4E Barge Flashing Cover –
Trapezoidal and Secret Fixed

8.4F

Dimension	Category		
	A	B	C
C2	1 rib	2 ribs	2 ribs
C1 (smooth surface)	50 mm	75 mm	75 mm
C1 (profiled surface)	75 mm	100 mm	125 mm

8.4G Barge Flashing Cover – Corrugate 8.4H

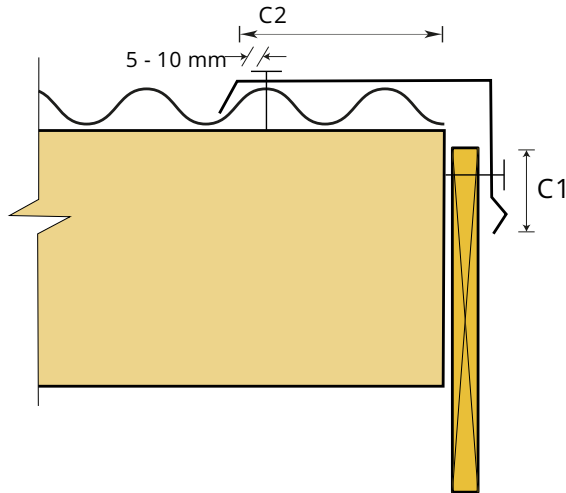

Dimension	Category		
	A	B	C
C2	2 crests	2 crests	3 crests
C1 (smooth)	50 mm	75 mm	75 mm
C1 (profiled)	75 mm	100 mm	125 mm

8.4I Transverse Apron Flashing Cover 8.4J

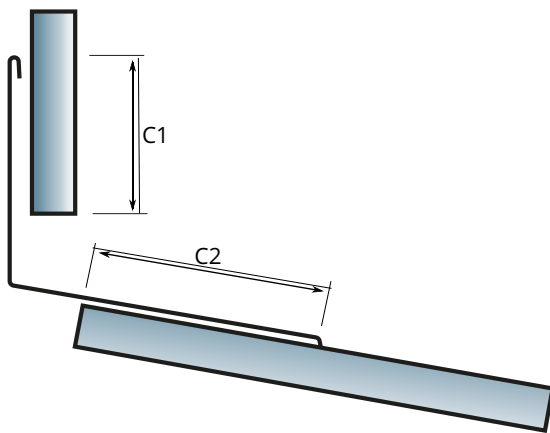

Dimension	Category		
	A	B	C
C1 (smooth surface)	50 mm + hem or 75 mm	75 mm + hem or 100 mm	100 mm + hem or 125 mm
C1 (profiled surface)	75 mm + hem or 100 mm	100 mm + hem or 125 mm	125 mm
C2	130 mm	200 mm	200 mm + baffle

8.4K Apron Flashing Cover – Trapezoidal

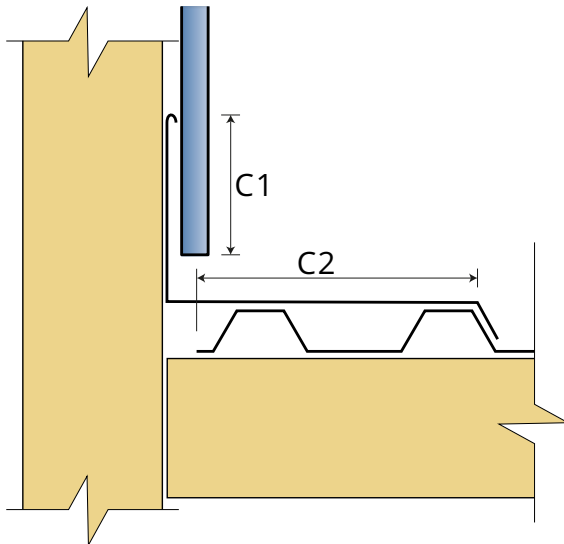

8.4L

Dimension	Category		
	A	B	C
C2	1 rib	2 ribs*	2 ribs
C1 (smooth surface)	50 mm + hem or 75 mm	75 mm + hem or 100 mm	100 mm + hem or 125 mm
C1 (profiled surface)	75 mm + hem or 100 mm	100 mm + hem or 125 mm	125 mm

*Not to exceed 300 mm. Two ribs cover can consist of two machined crests or one machined crest plus an upstand, hand-formed from the adjacent pan.

8.4M Apron Flashing Cover – Corrugate

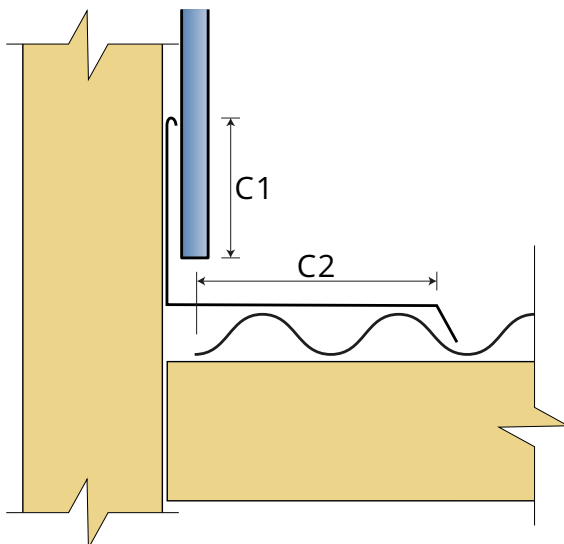

8.4N

Dimension	Category		
	A	B	C
C2	2 crests	2 crests	3 crests
C1 (smooth surface)	50 mm + hem or 75 mm	75 mm + hem or 100 mm	100 mm + hem or 125 mm
C1 (profiled surface)	75 mm + hem or 100 mm	100 mm + hem or 125 mm	125 mm + hem

8.4O Parapet Cap Cover

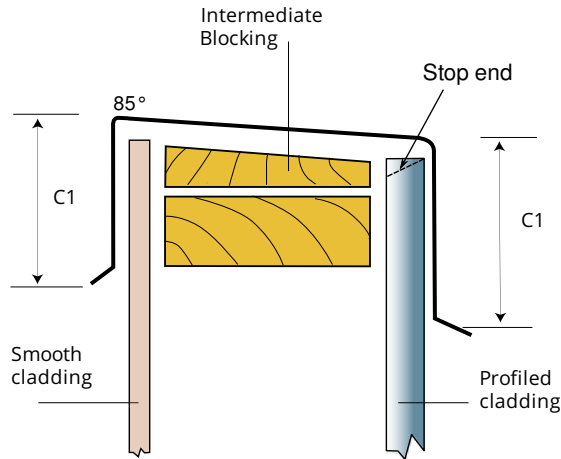

8.4P

Dimension	Category		
	A	B	C
C1 (smooth surface)	50 mm	75 mm	75 mm
C1 (profiled surface)	75 mm	100 mm	125 mm

8.4Q Change of Pitch Flashing Cover

8.4R

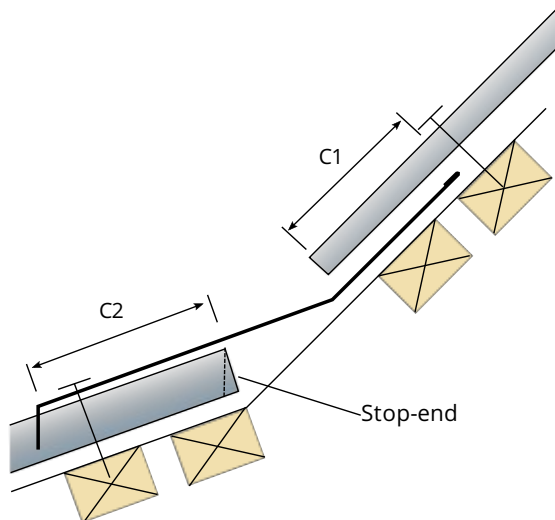

Dimension	Category		
	A	B	C
C1	250 mm	250 mm	300 mm
C2	150 mm	200 mm	200 mm

8.4.1 Apron Upstands

The minimum cover of the updated of an apron flashing varies depending on whether the upstand is hemmed or unhemmed, and the covering cladding is smooth or profiled. Profiled claddings require more coverage because they allow vertical air movement through the voids of the profile.

8.4.2 Clearances

The end of wall cladding should have a minimum clearance of 25 mm from an apron flashing or another horizontal surface. Where vegetation is present, or debris may accumulate, greater clearances or regular maintenance is required to achieve optimum durability. See [4 Durability](#).

8.4.3 Ridging and Other Transverse Flashings

A soft edge or notched flashing must be provided to transverse flashings. The positioning of the top purlin must be adjusted with the pitch and the ridge girth to ensure that primary fastening is provided between 15 mm and 50 mm from the leading edge of the flashing. See [8.4C Ridge and Head Flashing Cover](#).

8.4.4 Flashing Laps

Laps in flashings should comply with the following criteria:

- Water must flow over a lap, not into it,
- a lap must not rely solely on sealant,
- sealed laps must be mechanically fixed at 50 mm centres, and
- end laps must be a minimum of 150 mm for unsealed laps and 100 mm for sealed laps.

8.5 Flashing Types

Different types of flashings include:

- *Ridge and Hip.*
- *Barge and Verge.*
- *Parapet Cappings.*
- *Apron.*
- *Valley.*
- *Curved.*

See 9 *External Moisture Penetrations* for penetration flashings.

8.5.1 Ridge And Hip

Ridge and hip roll top flashings are roll-formed as a standard pitch flashing with a soft edge. When the angle of the flashing is not custom-made to suit the roof, it can result in visible distortion and stress around the fastening if used on pitches steeper than 35°.

Custom-made square top ridging is available for any pitch and width and is available in lengths of up to 8 m. The roll top or square top of a ridging helps accommodate expansion of the roof sheeting and strengthens the ridge.

A vee ridge is not able to support walking traffic and is vulnerable to buckling caused by point load and lateral or longitudinal thermal movement.

A soft-edged flashing can be used for corrugated and low rib trapezoidal profiles, and notched ridging can be used on all trapezoidal, trough or standing seam profiles.

8.5.1A Soaker Ridge Cap

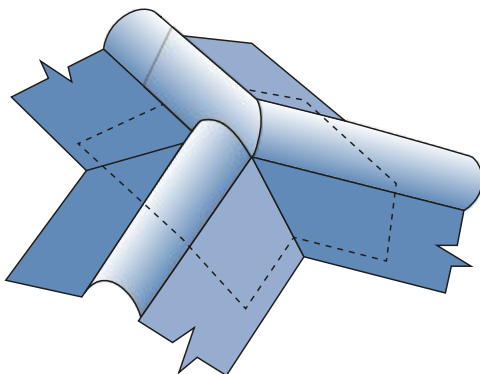

8.5.1B Ridge-hip Intersection

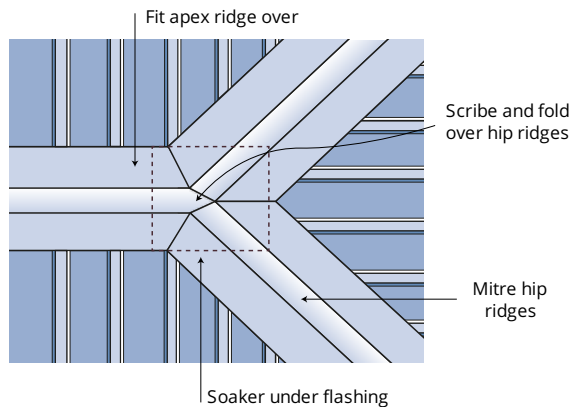

8.5.1C Ridge End

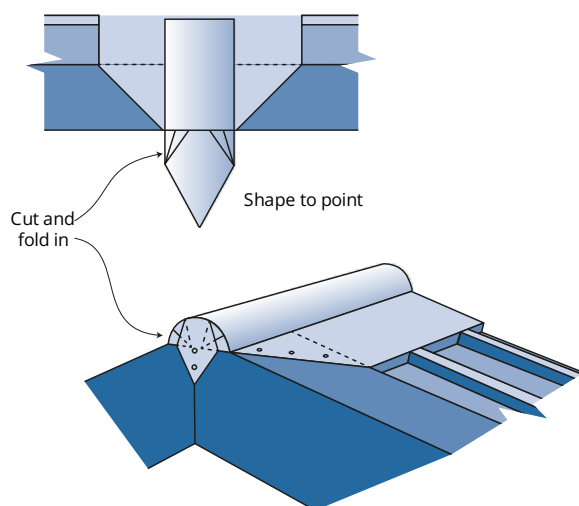

The transition of the ridge and the apex of a hip requires skill to make a neat and weathertight finish and relies on sealant for prolonged weather tightness. An under-flashing such as soft aluminium, waterproof tape, or EPDM membrane is recommended as a secondary means of making this joint waterproof in conjunction with the ridge-hip intersection design. (See [8.5.1C Ridge End](#))

The gable end termination of roll ridging must be made vermin proof by cutting the ridging back 25 mm and closing it. (See [7.4.1.1C Ridging End-Closure](#))

As an alternative to continuous ridging on ribbed profiled sheets, use individual rib or ridge caps fitted to each rib after the ribs have been cut and the roof cladding bent over the ridge. Each cap should be accurately fitted and sealed. This method does not allow for free expansion at the ridge of long length roof cladding and restricts natural ventilation of the ceiling cavity. These caps rely on sealant to be made watertight and are only recommended for use at the apex of a roof and when there is sufficient ventilation.

8.5.2 Barge And Verge

Barge or verge flashings assist in holding the roof cladding in place under high wind loads at the periphery.

Where barge flashings are omitted, the roof must be designed to withstand the upwards loads imposed on both surfaces of the roof cladding edges.

A transition flashing must be provided when the roof cladding weathers the barge at an internal angle.

8.5.2A Transition Flashings

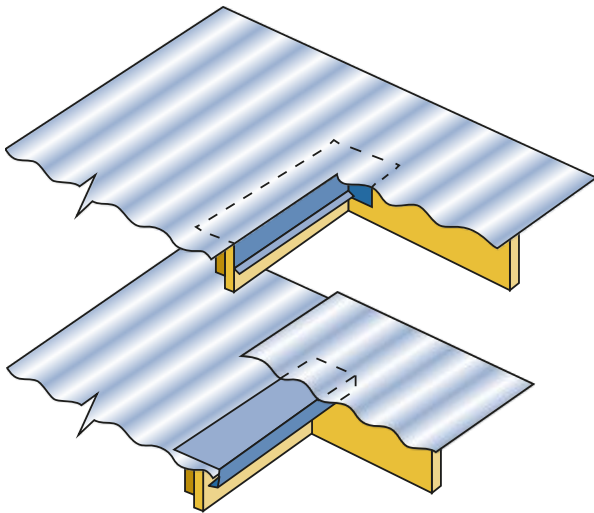

8.5.2B Stepped Fascia Corrugate Under Barge

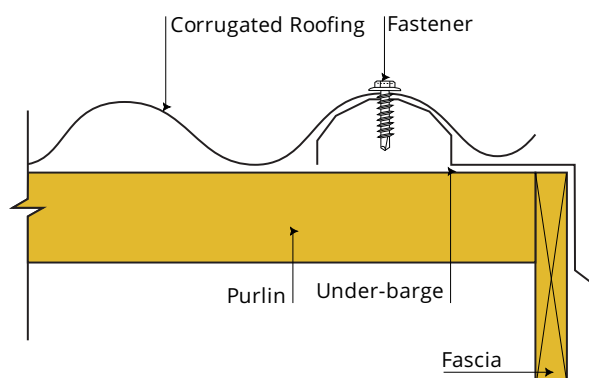

8.5.2C Stepped Fascia Corrugate Over Barge

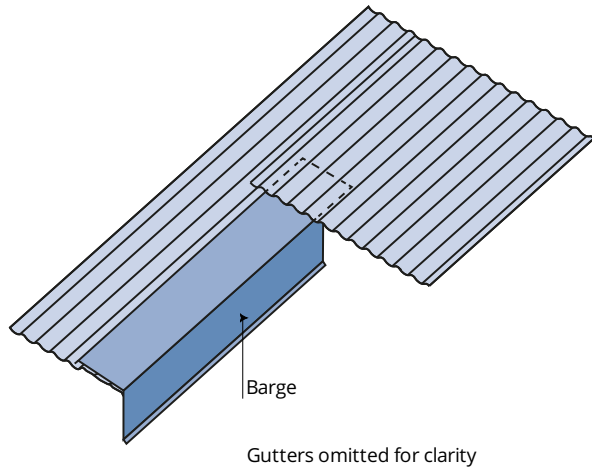

8.5.2D Stepped Fascia Trapezoidal Under Barge

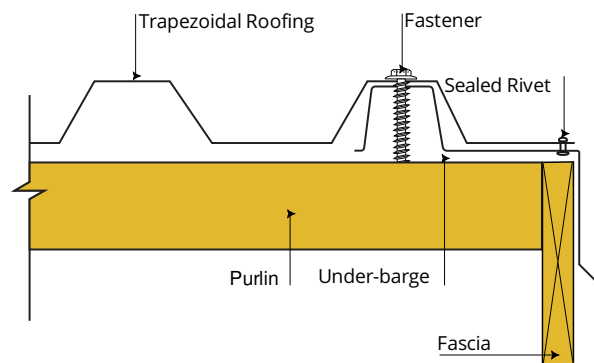

8.5.2E Stepped Fascia Trapezoidal Over Barge

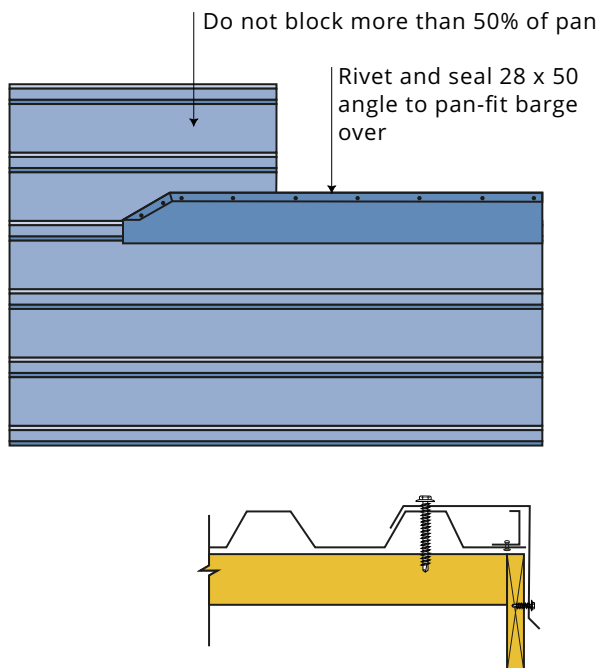

8.5.2F Tray Roofing-Wall Connection

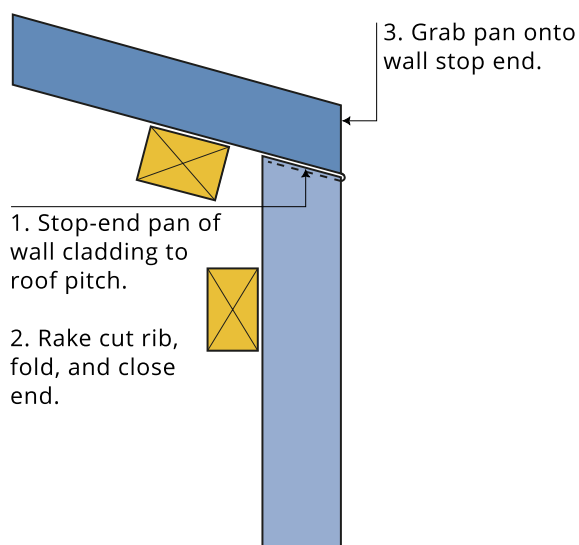

8.5.2.1 Ridge – barge Intersections

8.5.2.1A Shorter Gable meets Eave Overhang

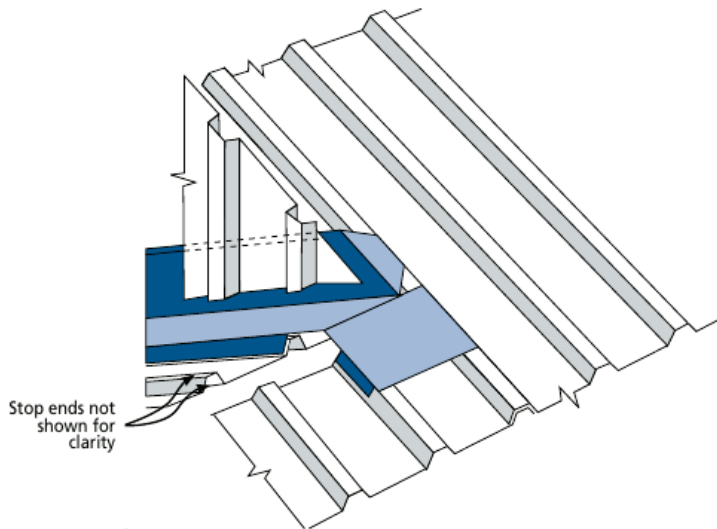

8.5.2.1B Barge Flashing on an Internal Corner

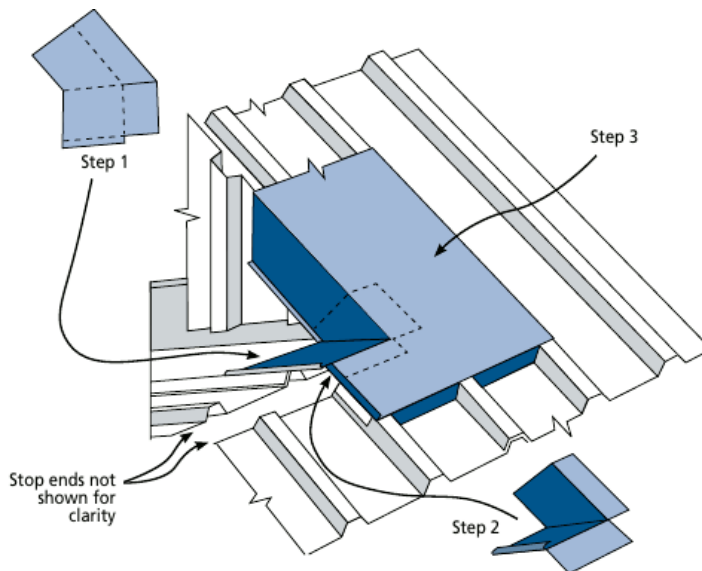

8.5.2.1C Barge Flashing – Ridge Cap

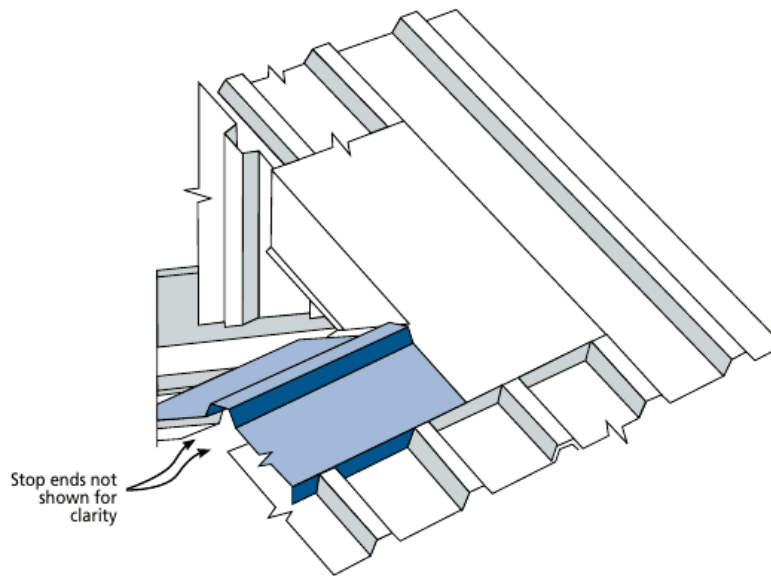

8.5.3 Parapet Cappings

Cappings are flashings used to cover the top of a parapet wall to protect the wall from the ingress of moisture. As leaks in parapets are often not immediately noticed and can result in damage to the structure if not quickly detected, good design, installation, and maintenance of parapet caps are important.

8.5.3A Parapet Cap Expansion Provisions

To maintain the integrity of laps, adequate expansion joints must be provided as per this table.

Parapet flashing design	Expansion joint positioning
Fixed aluminium	Every 6 m
Clip-fixed aluminium	Every 12 m
Fixed steel	Every 12 m
Clip-fixed steel	Every 20 m
Internal and external corners	Within 2 m of each corner.

The corner of the wall is a fixed point for the capping, and as thermal movement can only occur in one direction away from the corner, an expansion joint should be provided as shown for length in either direction exceeding 2 metres.

8.5.3B Parapet Capping Expansion Joint

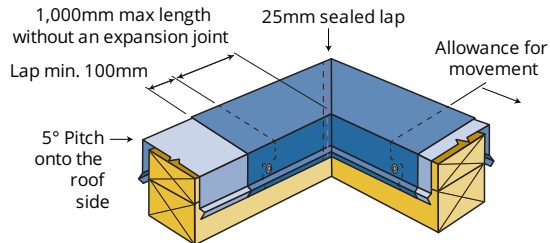

8.5.3C Cap-fixed Parapet Cross-section Detail

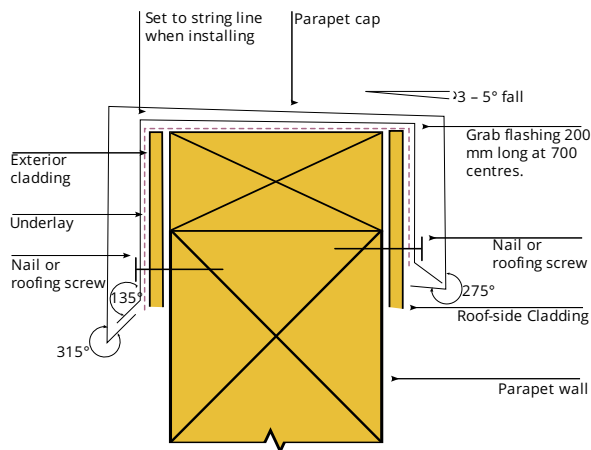

Clip-fixed parapet are preferable where leaks will cause damage to the structure as having free provision for expansion will reduce the amount of stress on the joint fasteners.

Fixed cappings must not be fastened to the structure through the top of the capping, but can be fixed on one or both vertical legs by one of three methods. Having a clip fastened outer edge will minimise rippling of the face but will not allow the free movement of a clip fastened option.

1. The capping is fastened to the parapet on both sides using screws with embossed washers through oversized holes.
2. A continuous cleat is fastened on the exterior face of the wall with an open hem at the drip for ease of application. After the exterior face of the capping is hooked to the cleat, the capping on the interior side is secured to the parapet using fasteners with embossed washers through oversized holes.
3. Intermittent clips are fastened to the exterior face of the wall at 600 mm centres. All cleats and clips should be accurately aligned by string line during installation

8.5.3D Fixed Cap to Concrete

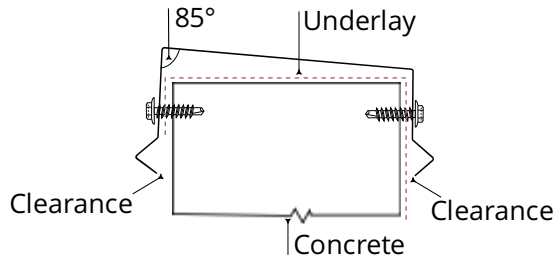

8.5.3E Clip-fixed Parapet Cap to Smooth Profile Inner

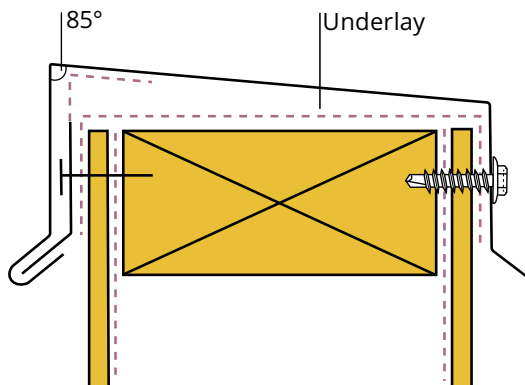

8.5.3F Parapet Cap Fixed to Profiled Cladding

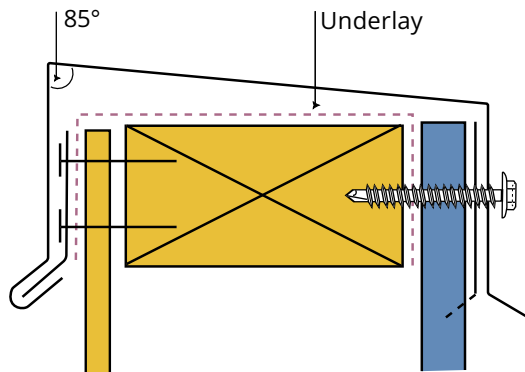

Instead of chasing into the wall or using a [E Parapet Flashing – Face-Fixed](#), the preferred detail is to cover the inside of the parapet wall with vertical ribbed metal or other cladding material, used in conjunction with an apron flashing and parapet cap. (See [8.5.4B Vertical Cladding \(Parapet Flashing and Detail\)](#))

Parapet Cap Slope

Parapet cappings that follow the slope of the roof do not require any fall across its width, but transverse parapet cappings must have a positive slope of onto the roof side to avoid ponding and encourage free draining. This slope should be 3 – 5°. Parapet cappings wider than 300 mm can fall both ways, with the drainage slope provided on each side.

8.5.4 Apron Flashings

Cladding should not fit tightly onto the horizontal surface of any apron flashing; as it could retain moisture and collect dirt and debris. It should have a minimum clearance of 25 mm to allow for cleaning and maintenance.

Apron flashings should be in position before the cladding is installed. Where replacement of the flashing requires removal of the cladding above it, *Figure 1 and Table 1 of B2/AS1* require the flashing to have a durability of 50 years. Durability can be achieved by using flashings made from non-ferrous materials. Alternatively, a [8.5.4F Two-piece Apron](#) should be used where the over-flashing has 50-year durability, and the apron flashing can be renewed independently.

When the parapet walls will be plastered or when other trades are likely to follow the roof cladding installation, the roof cladding, and flashings should be protected from damage. Provision should also be made for working and walking on the roof cladding during this time.

Where an apron abuts a block, brick, or concrete wall without any cladding above it, the apron flashing can be weathered by a step or a continuous chased flashing. These flashings can be made from aluminium, stainless steel, or zinc when used with metallic-coated steels and should extend 25 mm into the wall. They should be hooked or mechanically wedged and should be sealed using a compatible, flexible mortar or sealant. Over-clad flashings give better weather protection than chase-cut flashings.

8.5.4A Chased Apron

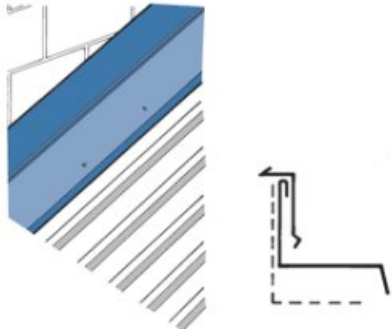

8.5.4B Vertical Cladding (Parapet Flashing and Detail)

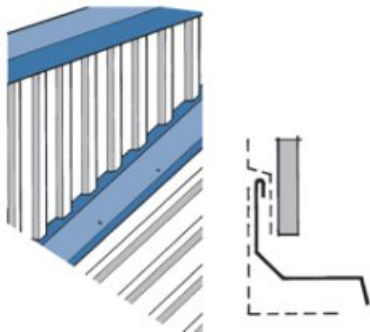

8.5.4C Angle Diverter

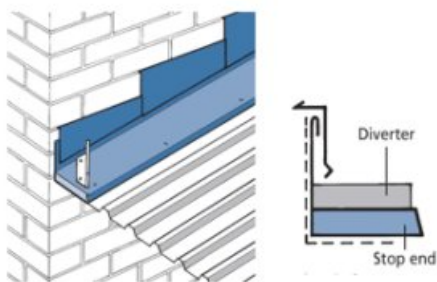

8.5.4D Angled Apron – 110°

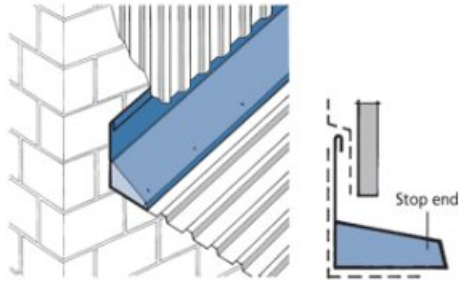

8.5.4E Angled Apron – 45°

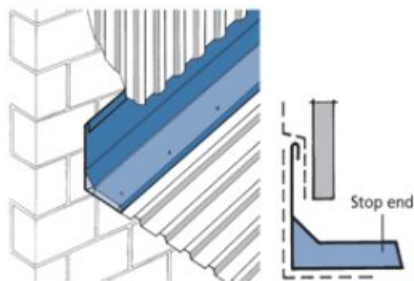

8.5.4F Two-piece Apron

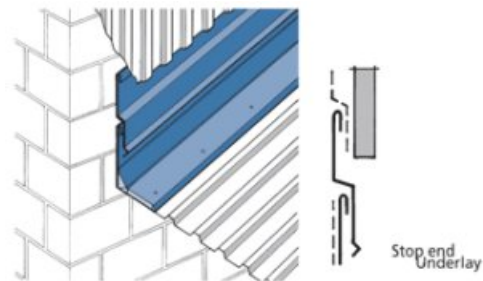

8.5.4A Chased Apron and 8.5.4C Angle Diverter are not the preferred installation methods for apron flashings. 8.5.4B Vertical Cladding (Parapet Flashing and Detail) shows a better method that provides more positive weathering by covering the wall with vertical metal cladding up to the capping.

It is not possible to ensure that all the water discharged from the apron flashing will be collected by the spouting, unless special provisions are made including:

- an angle diverter should be sealed and fastened to the apron. (See 8.5.4C Angle Diverter);
- the side apron flashing can be folded to 110° (see 8.5.4D Angled Apron – 110°);
- an apron internal angle flashing can be folded to two angles at 135° (See 8.5.4E Angled Apron – 45°); or
- using a two-piece apron (See 8.5.4F Two-piece Apron).

Spouting should be fitted after the wall has been finished and should be clear of the wall cladding.

Aprons should be stop-ended and turned down to weather and bird-proof the end of the apron at this junction.

When flashing a cavity parapet, the apron should be in place before the cavity batten as it is not possible to

retrofit the apron. The apron material should have a 50-year durability unless the parapet cladding is easy to replace.

When a chase or rebate (8.5.4G Chase-fixed Flashing) is not provided, a pressure bar flashing can be used to weather an apron flashing into a concrete tilt-up slab wall.

8.5.4G Chase-fixed Flashing

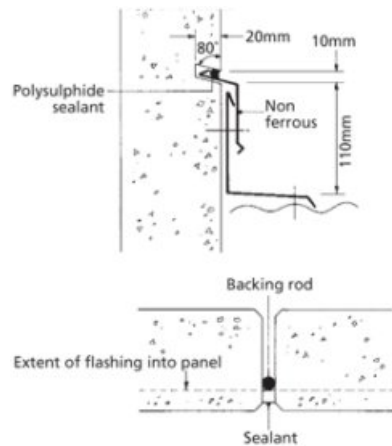

Over-clad apron flashings are always preferred to chase-cut alternatives in structures such as residences where the occurrence of chase-cut weatherproofing failure could have severe consequences.

8.5.4H Parapet – Reglet Flashing, Chase Cut

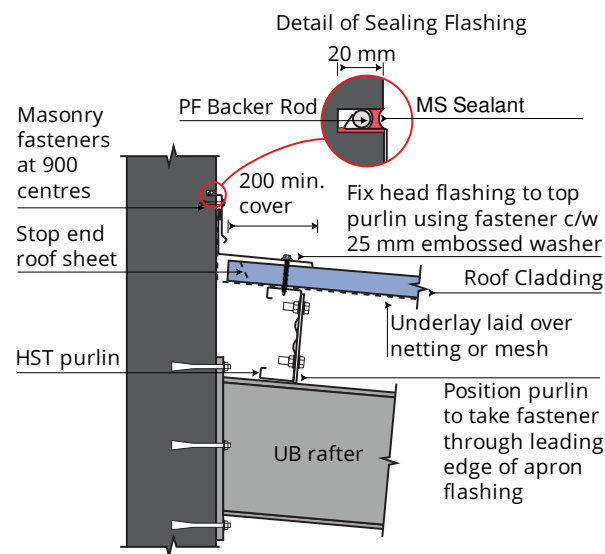

8.5.4I Parapet – Reglet Flashing, Face Fixed

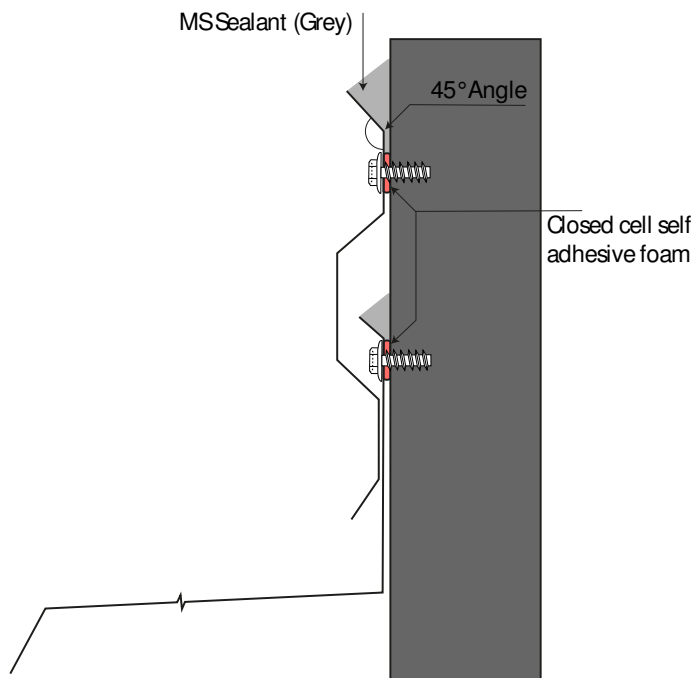

8.5.4.1 Parapet And Apron Capping Terminations

A junction where an apron flashing meets a ridge can be weathered by two methods.

1. By carrying the apron over the ridge and covering the joint with the ridding as shown in [8.5.4.1A Parapet/Apron Ridge Cap](#).
2. By making a separate saddle flashing as shown in [8.5.4.1B Separate Saddle Flashing](#).

8.5.4.1A Parapet/Apron Ridge Cap

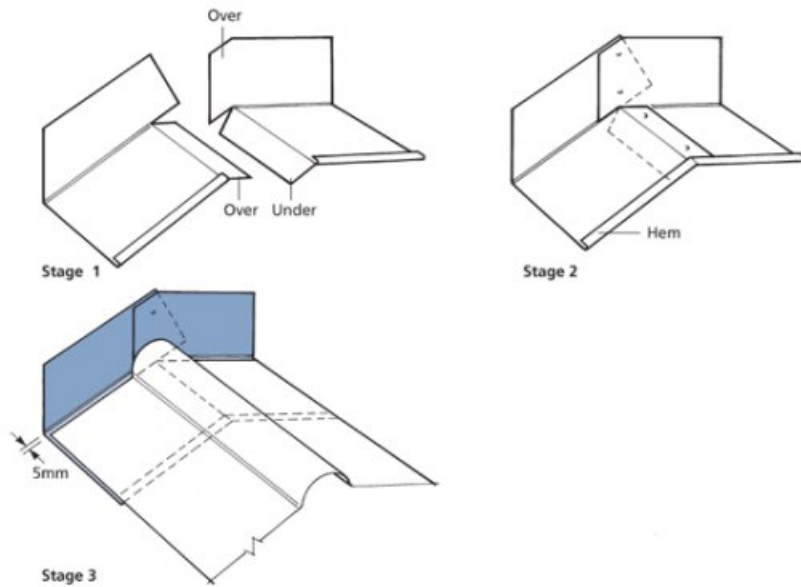

8.5.4.1B Separate Saddle Flashing

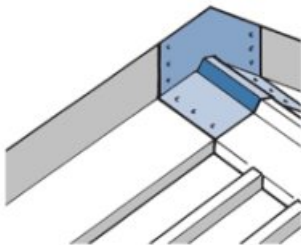

8.5.4.1C Corner Abutment

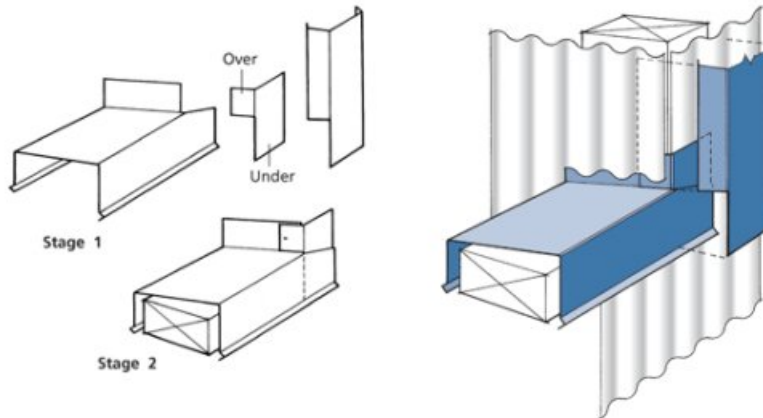

Parapet cappings should have a separate cap at the apex or be joined as shown in [8.5.4.1D One-piece Parapet Ridge](#).

8.5.4.1D One-piece Parapet Ridge

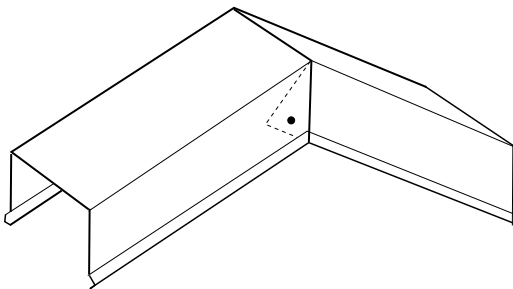

8.5.4.1E Two-Piece Parapet Ridge

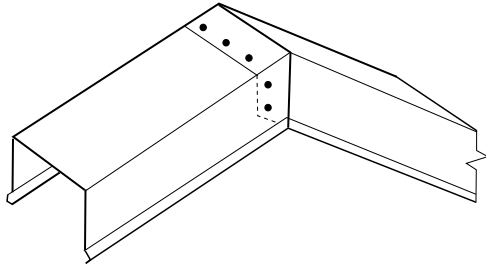

8.5.4.2 Change Of Pitch

Differential movement will happen at any change of roof cladding pitch where the sheets are overlapped and butted together. This movement causes noise and deterioration of the coating. A separate apron flashing as shown in [8.5.4.2A Change of Pitch Junction Flashing](#) is required to prevent that.

A junction flashing must be used where sheeting is cut at a change of pitch. The junction must be hooked and have the minimum coverage as required according to the exposure category in [8.4.4 Flashing Laps](#). The underlay must overlap the flashing as shown.

8.5.4.2A Change of Pitch Junction Flashing

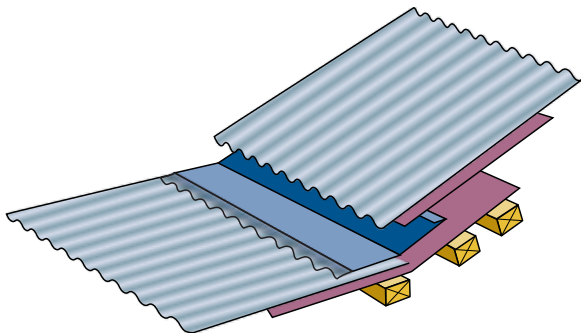

8.5.4.3

Step Apron

A step apron or waterfall flashing must be used where the length of roof cladding is more than can be transported, or exceeds the recommended length for expansion as shown in [7.3.2 Roof Cladding Expansion Provisions](#).

The designer should allow a minimum 20 mm step in the purlin height to accommodate a step apron, giving a total change of height equal to 20 mm plus the profile height. The purlin height can be adjusted at the purlin cleat or by using a different size purlin.

8.5.4.3A Step Apron Details

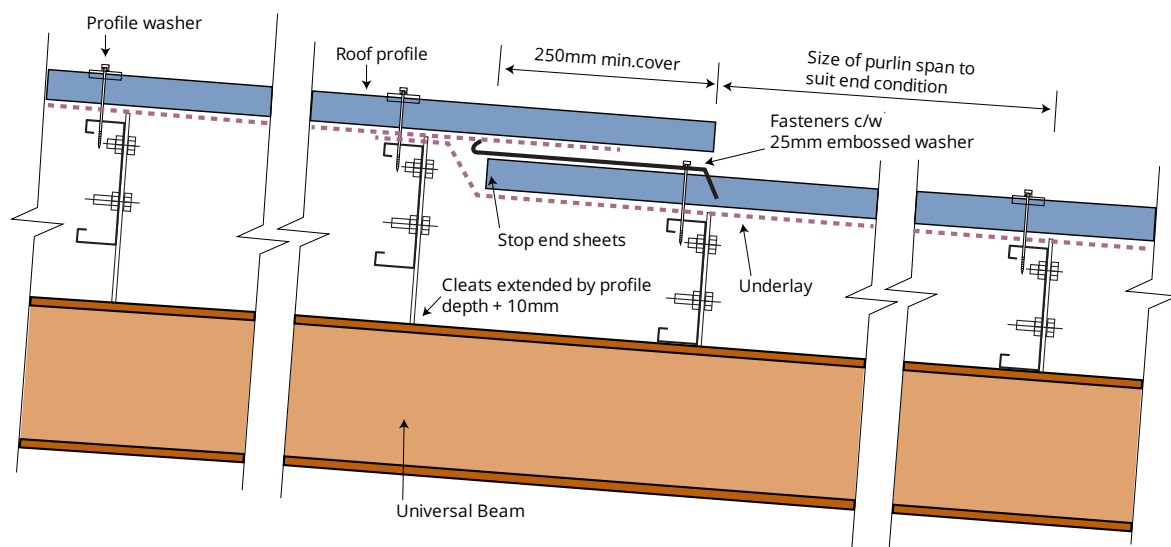

8.5.4.3B Stepped Roof Flashing

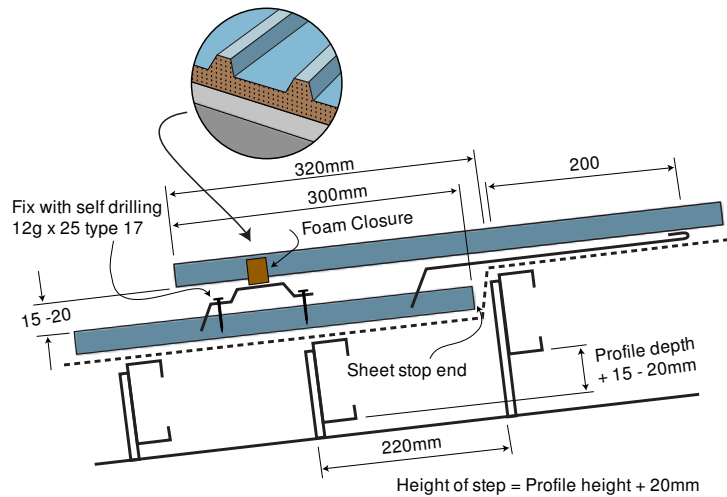

8.5.4.4 Eaves Flashing

Gutter eaves flashings are not required for weatherproofing unless the building is in a very exposed location and the eaves are not protected by spouting. They can, however, serve a purpose in many applications of improving the durability of roofing at the eaves.

The flashing should extend into the gutter, and the underlay finishes on the down-slope of the flashing. If there is no over flashing to the gutter, the underlay should be extended into the gutter by a maximum of 20 mm.

Unwashed flashings should be made of durable materials such as organic coated steel, aluminium, or PVC.

Eaves flashings as referred to in E2/AS1 are not required for weatherproofing unless the eaves are unprotected by spouting, but they can make a contribution to durability.

Eaves flashings are recommended in Marine Environments to improve the durability of the roof cladding and are required for pre-painted aluminium roofs (see 14.9). Eaves flashings may be pre-painted steel or aluminium (either pre-painted or uncoated). To minimise the build-up of salt deposits at the eaves, a high-fronted gutter fully covering the roof crests, attached closely to the fascia, is recommended in Severe and Very Severe Marine environments.

8.5.4.4A Gutter-Eaves Flashing

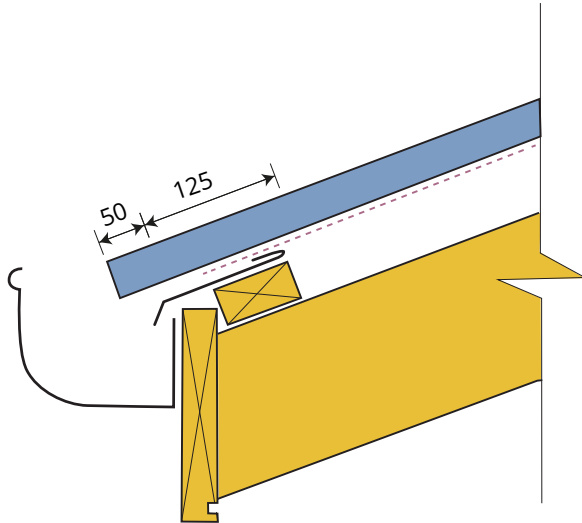

8.5.5 Curved Flashings

Drape curved and crimp curved metal roof cladding requires curved barge and apron flashings which may not always have an even radius.

There are two different ways to form curved flashings, all of which require specialist equipment.

- lock-forming or lock seaming; or
- crimping.

Manufacturing curved flashings is a highly skilled operation and should be done in a factory by skilled workers.

8.5.5.1 Lockseamed Flashings

All lock-seamed flashings should be custom-made to suit the profile shape and the rib distance from the fascia with sufficient downturn on both sides to weather the junction. Lock-seamed flashings are made in two parts, the horizontal (part a) and the vertical (part b). Edges can be either crimped or lock-seamed, as shown in these drawings.

8.5.5.1A Lockseamed Curved Flashing

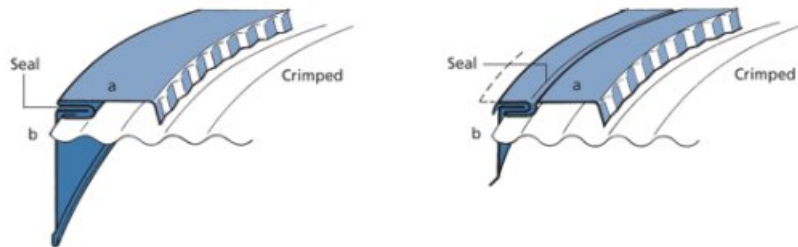

The vertical barge component (part b) can be cut to the curve and lock-seamed, with the horizontal component (part a) hooked and seamed jointed. (See [14.22 Tools Of The Trade](#).) The outside edge can be crimped as shown here, or hemmed.

Shallowly curved flashings can be folded straight in one piece and crimped on both edges. Fix the turn-down at the curved rib by “mini-crimping” or “gear-crimping”.

8.5.5.2 Crimped Flashings

Crimped flashings are suitable for use on radii of more than 2 m, with the crimp spaced and deformed at regularly spaced intervals. A flat strip should be placed on the template and crimped until the strip fits the template.

Because the flashings are seen from much closer, domestic clients may find this type of flashing aesthetically unacceptable.

8.5.5.2A Regularly Spaced Crimp (Crimp Flashing)

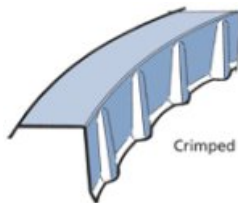

8.6 Fastening Flashings

Flashings must be fastened in one of three ways.

- By primary fastening – fastening into the main structure.
- By secondary fastening — fastening into the cladding.
- By means of clips, cleats or seams to allow for differential movement of the roof cladding and the flashings.

For full details on fixings, see [14.13 Fasteners](#).

8.6.1 Primary Fasteners

Primary fasteners are fixings that attach flashings to the structural building frame and which should withstand all the loads applied to the cladding, including expansion provisions. Primary fasteners are relied on for structural performance. Flashings should be fastened at a point within 25 mm from the exposed edges of the flashing, and the primary fastener spacing should be to each structural member it crosses.

Flashings should be fixed on both edges.

Putting bonded or embossed washers under all primary fasteners through the horizontal upper surface of flashings improves weathertightness.

8.6.2 Secondary Fasteners

Secondary fasteners are fixings that attach flashings to sheets and one another to transfer loads and provide lap sealing. Rivets and stitching screws are secondary fasteners used to fasten flashing laps. They are subject to shear loading due to expansion and differential movement.

Sealing washers are required on all secondary fasteners, except under rivets which should themselves be sealed or self-sealing.

8.6.3 Flashing Cleats

A flashing cleat is a continuous metal under-flashing installed behind the leading edge of a metal capping or flashing. Cleats secure cladding or flashings to the substrate or structure using a slip joint or by crimping the leading edge of the flashing to the cleat.

Cleats and clips should be accurately aligned and clinched after fixing to avoid vibration or chatter, but should still allow for expansion of the flashing.

Cleats are fastened to the substrate using mechanical fasteners and should be made from the same metal as the flashing or sheeting.

To allow for differential expansion and contraction, the flashing should be securely hooked to the drip edge of the cleat but should not be attached directly to it.

8.6.3A Flashing Secured to a Cleat

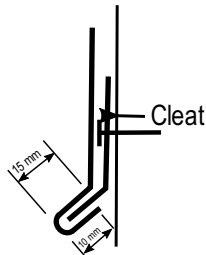

8.6.4 Seams

Flashings can be joined together by various types of seam to avoid a plain lap joint without sealant. If the joint is likely to retain moisture and it is required to be sealed, the sealant should be introduced into the joint before it is completed.

8.6.4A Lap Seam

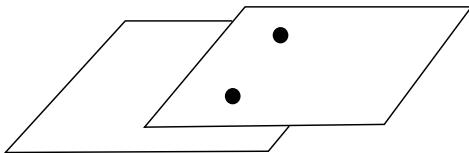

8.6.4B Lock Seam

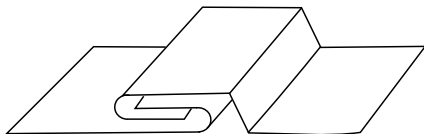

8.6.4C Drive Cleat

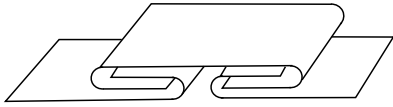

8.6.4D Soaker

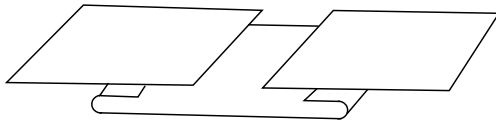

8.6.4E Standing Seam

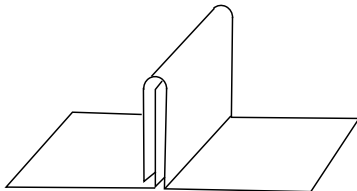

8.6.4F Single-lock Standing Seam

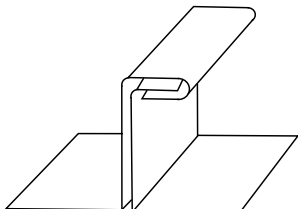

8.6.4G Double-lock Standing Seam

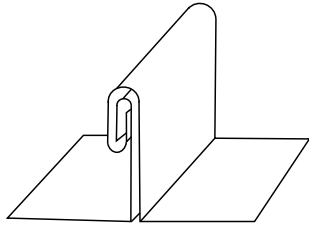

8.6.4H Pittsburgh Lock

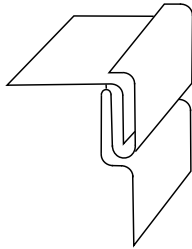

8.7 Sealants

Sealants play an important part in cladding because AZ or paint coatings cannot be sealed using solder.

The purpose of sealants used in the joints between metal roof and wall cladding and flashings is to prevent the entry of rain or snow and to exclude dirt, debris, and moisture by capillary action. They may also have varying degrees of adhesive action.

Sealants are generally Neutral Cure silicone or Modified Silicone (MS) types. The latter is generally paintable. Proprietary self-adhesive tape sealants are also entering the market and give excellent performance in certain conditions. Acid cure sealant, designed to bond to inert surfaces such as glass, must not be used.

Designs using sealants to seal sheet components must always include a mechanical fastening such as a screw, rivet or a mechanical seam.

Generally, the function of a sealant is carried out by that sealant being sandwiched in the joint. In most cases, the post application of sealant to the outside of a joint is both futile and unacceptable.

The sealant does not require significant total adhesive strength, but it should bond positively to both surfaces as a continuous layer. To ensure complete sealant cure, the width of sealant in a lap should not exceed 25 mm when compressed

8.7.1 Methods Of Sealing

There are two main methods of sealing metal sheets – gun applied sealants and self-adhesive tapes.

Sealants should have a low resistance to compression so that metal sheets can be brought closely together by their fasteners and not held apart by the sealant.

8.7.2 Surface Preparation

For adequate bonding, all surfaces must be clean, dry and free from contaminants, such as rolling oils, dirt or dust.

8.7.3 Sealant Extrusion And Placement

Sealant should be gun-applied in a continuous flow to provide a joint without gaps or voids. This will prevent the entry of both condensation from above and water drawn up by capillary action, either of which can cause metal corrosion.

After placing the sealant cartridge in the gun, the tapered nozzle should be cut with a sharp knife at an angle of 45 ° at a position which would provide a bead of sealant approximately 6 mm in diameter.

8.7.3A Applying Sealant

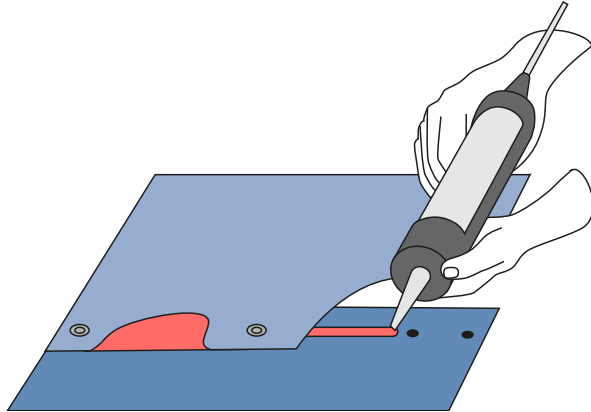

Sealed rivets are the preferred fastener. The stem holes of unsealed blind rivets must be sealed with silicone, which can attract dust and look unsightly.

Sealant should be placed in a continuous bead close to the weather end, covering any pre-drilled rivet holes. If a complete ring of sealant is applied around the fastener, an air pocket forms which compresses during tightening of fasteners. It can blow a channel, thus preventing an effective seal.

The best method for lap fabrication is.

- Assemble and drill the components. Rivets should be positioned at 50 mm spacings.
- Separate the components and remove any drilling swarf.
- Remove any strippable film.
- Clean the joint.
- Apply a continuous sealant bead as described above.
- Relocate the components, align the holes and fasten.
- Externally seal the centre of all rivets if required.
- Remove surplus sealant after it has cured (not while uncured), to avoid smearing.

When placing the overlapping sheet, care should be taken to avoid disturbing the sealant when fastening.

Excess sealant should be removed with a plastic spatula or purpose made plastic scoop as excess sealant collects dirt that is unsightly.

Visible excess of sealant is not an acceptable trade practice.

8.8 Profile Closures

Profiled closures are available for all profiles. They are available in narrow tip (for going under the profile) or wide tip (for fitting over).

8.8A Narrow Tip Profiled Eaves Closure

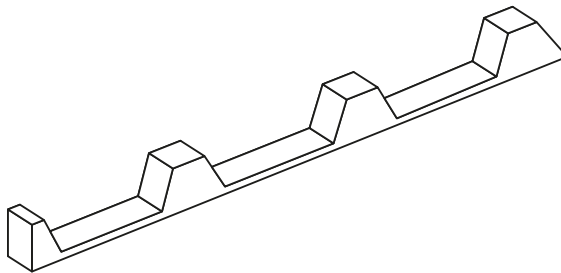

8.8B Wide Tip Profiled Eaves Closure

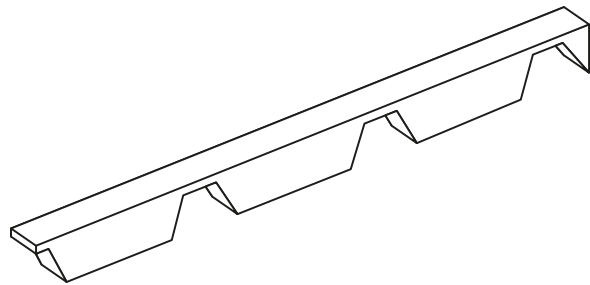

As they restrict the free movement of air, their use should be restricted to where they are required for weatherproofing and appearance (such as scribes under window jamb flashings) or for maintaining positive internal pressures, such as in building with a managed internal environment. Profiled closures should be of closed cell type, rather than bitumen impregnated.

In marine areas, corrosion is likely to initiate under apex flashings and under the eaves overhang, regardless of whether profiled foam is used. A high fronted spouting is the best protection against the eaves corrosion. In very severe cases, or where there is a gap between the back of the gutter and the fascia, an eaves flashing of durable material (e.g., aluminium or plastic) can be used to prevent much of the salt build-up on the underside of the roof cladding. (See [8.5.4.4 Eaves Flashing](#))

8.8C Purlin-Fixed Profiled Eaves Closure

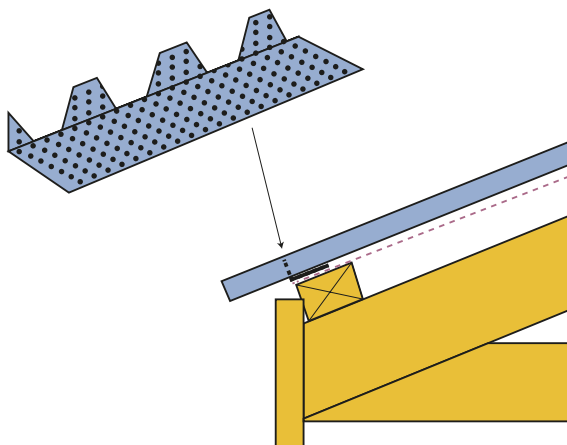

8.8D Fascia-Fixed Profiled Eaves Closure

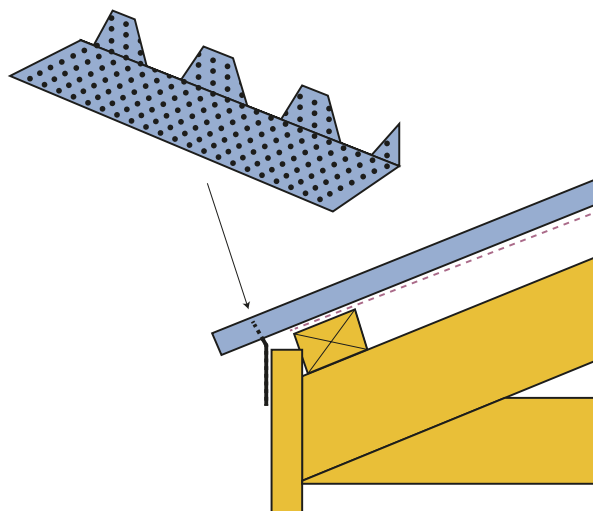

8.8E Eaves Comb

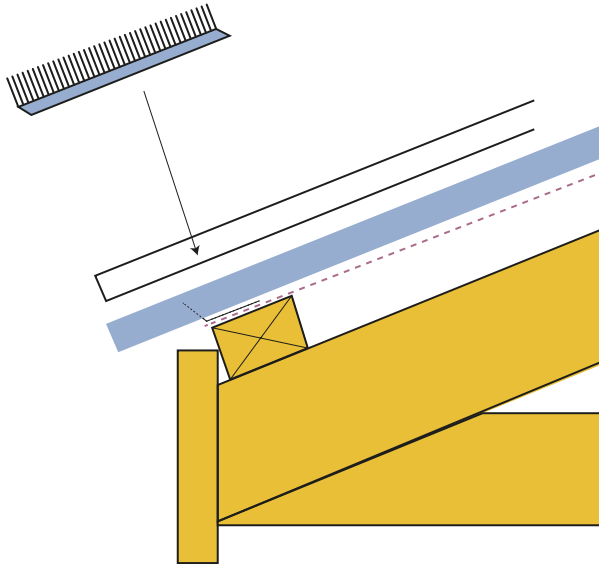

For vermin control, a perforated scribed aluminium flashing, or an eaves comb, may be used.

In marine areas, corrosion is likely to initiate under apex flashings and under the eaves overhang, regardless of whether profiled foam is used. A high fronted spouting is the best protection against the eaves corrosion. In very severe cases, or where there is a gap between the back of the gutter and the fascia, an eaves flashing of durable material (e.g., aluminium or plastic) can be used to prevent much of the salt build-up on the underside of the roof cladding. (See Eaves Flashing)

8.8F Eaves Corrosion due to Low Fronted Gutters



Low fronted gutters in severe conditions will often lead to eaves corrosion

8.8.1

Soft Edging

To prevent the ingress of weather, dirt, or birds, it is common practice in New Zealand to close the openings created by the pan and ribs of profiled sheets using notched metal flashings or soft edging. Lead was the traditional material for this application, but as it is incompatible with AZ coatings, soft aluminium edging or composite materials are offered as an alternative.

Proprietary soft edging is available for corrugated and low trapezoidal profiles, consisting of an expandable aluminium mesh with a flexible backer.

All soft-edged flashings should be primed and colour painted before installation – but the preferred option is for the paint finish on soft edges to be factory painted under controlled conditions.

Soft-edged flashings are available in a partially-backed form to facilitate passive ventilation at the apex. (See [Internal Moisture](#))

8.8.2 Notched Edging

Where the profile height exceeds 30 mm, a notched flashing is the preferred option.

All scribed edges should have clearance to avoid damaging the coating of the roof sheet. The scribed metal edge of any flashing must have a clearance of 2 mm to 5 mm.

8.9 Compression Timber

8.9A Buckled Ridge Flashing



Before any transverse flashings are fixed, the framing timber must have a maximum moisture content of 12%.

Transverse flashings, such as ridging, are sometimes prone to compressive buckling which is blamed on metal expansion but is usually due to timber shrinkage, and a phenomenon known as compression timber.

8.9B Compressed Timber



Compression wood has a darker appearance in the early wood (summer) growth rings; to visually distinguish such severity levels in sawn timber accurately requires microscopic identification. (Source: Rooflink)

Abnormal growth causes this defect in timber, which can cause shrinkage ten times more shrinkage than normal.

It is not easy to recognise compression timber visually and roofers are advised to measure the moisture content, particularly of ridge purlins, before fixing. Framing timber must have a maximum moisture content of 12% before any transverse flashings are fixed.

Alternatively, use steel top hat purlins.

8.10 Flashing Expansion Details

Expansion should be considered at the design stage, and the flashing details should be included in the working drawings and tender documents. As flashings cannot move in the lateral direction without stress, they should have some provision for longitudinal expansion when their length exceeds 18 m, or for lesser distances for visual flashings such as fascias and facades.

When using an expansion joint, independence of movement should be assured by the omission of any fixing through both sides of the joint. Preferred and acceptable slip joint expansion details are shown in **8.10A Apron Slip-joint** and **8.10B Ridge Slip-joint**. Soaker expansion joints relying on sealant should not be used.

Slip joints require sealants, not to make them weatherproof, but to exclude dust and dirt from two close fitting surfaces, which can retain moisture by capillary action and cause corrosion. Rivets and other fasteners must not prevent movement of the slip joint.

8.10A Apron Slip-joint

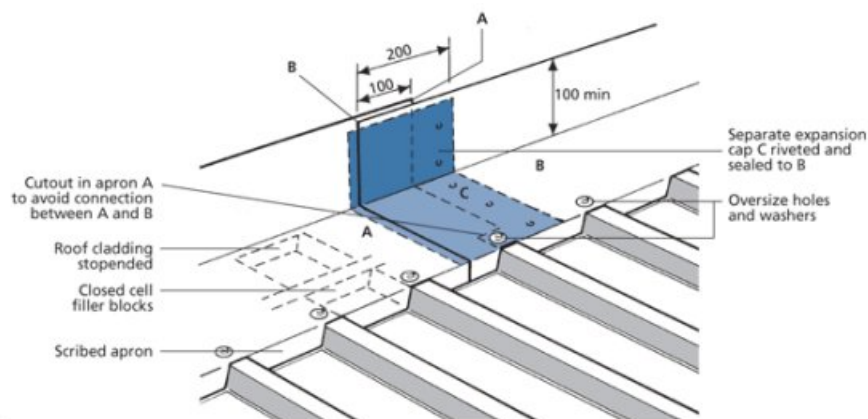

8.10B Ridge Slip-joint

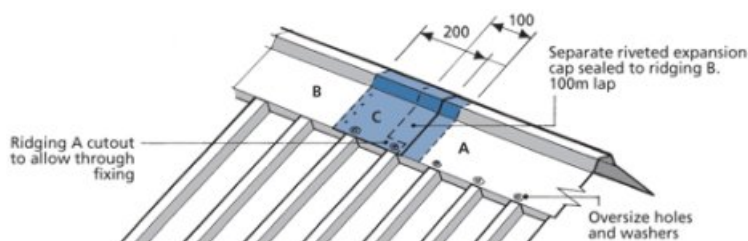

8.10.1 Flashing Expansion

Before any transverse flashings are fixed the framing timber must have a maximum moisture content of 18%.

Transverse flashings, such as ridging, are sometimes prone to excessive buckling which is blamed on metal expansion but is usually due to timber shrinkage, and a phenomenon known as compression timber. Abnormal growth causes this defect in timber, and it can shrink up to 10 times more than normal. It is not easy to recognise compression timber and roofers are advised to measure the moisture content, particularly of ridge purlins, before fixing.

An alternative is to use steel top hat purlins.

Fixing roof cladding should be treated in the same way as internal linings, i.e., do not fix transverse flashings when the moisture content of any timber is more than 18%. The thickness of flashings should always comply as specified in [8.1 Flashing Materials](#)

If flashings are positively fixed, framing timber that does not meet this requirement can cause failure of ridging and flashings due to timber shrinkage when drying.

The metal expansion allowances quoted in many publications can be misleading because the information is based on theoretical metal expansion values and is not related to real-world conditions.

Figures published for metal expansion rates are given linearly per degree, but it does not take into account the many other factors that mitigate the theoretical figure. (See [7.3 Thermal Expansion And Contraction](#).)

It is necessary to make provision for cladding and flashing movement; when long lengths are used and positively screwed or riveted together, they should be regarded as one length.

The maximum length before expansion provision should be made for either cladding or flashings will vary according to colour, micro-climate, ventilation and fixing spacings. It is, however, possible to provide indicative figures based on a study of empirical data over time. The maximum recommended flashing length without any expansion provision is similar to that of roof cladding. (See [7.3.2 Roof Cladding Expansion Provisions](#).)

Aluminium rivets, which have a low shear value, will fail when there is no provision made for expansion in flashing lengths of over 12 m. Using aluminium joints is only acceptable if they are used at the prescribed distances, and are not used to replace expansion joints.

Lengths of coated steel ridging, cappings, and apron flashings over 12 m should have a slip joint as described in [8.10 Flashing Expansion Details](#).

Inadequate provision for expansion can also cause Roofnoise.

8.10.2 Building Expansion Joints

Expansion joints should be designed to accommodate contraction and expansion. Expansion joints should be detailed and constructed to a minimum height of 100 mm above the roof cladding, and curb-type expansion joints should be designed and installed to ensure drainage of the roof and to prevent any damming of water.

Wood curbing secured to the substrate on both sides of an expansion joint should be flashed with a metal capping capable of acting as an expansion joint cover.

Expansion joints have two main designs.

1. A **8.10.2A One-piece Expansion Joint** to accommodate movement using a central bellows or roll that allows the flashing to be positively fixed on both sides.
2. A two-piece design to accommodate movement by the use of hemmed edges, with sufficient clearance for the expected movement.

8.10.2A One-piece Expansion Joint

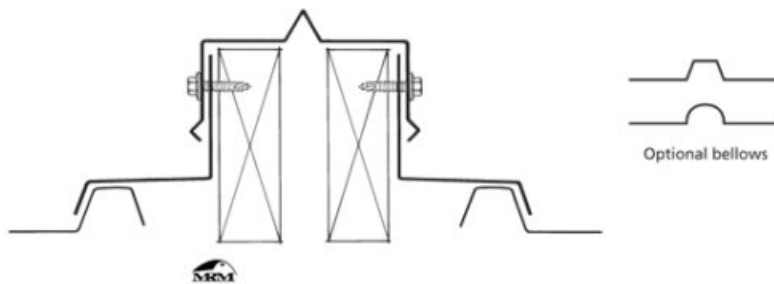

8.10.2B Two-piece Expansion Joint

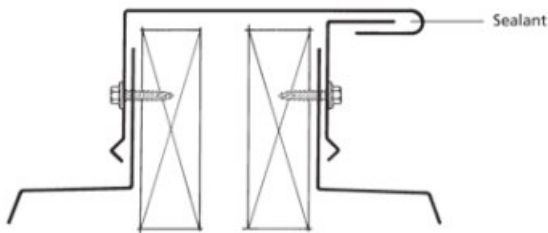

Both of these designs are shown as a parapet following the pitch of the roof. Where this is not the case, the top of flashing should have a 10° slope as for all other parapet flashings. (See **8.5.3 Parapet Cappings**).

Metal wall construction joint flashings that are embedded in the wall should be made with a bellows or other means of accommodating movement without fatigue and have a durability of 50 years.

8.11 Metal Wall Cladding Flashings

Flashing details for cladding using profiled metals should:

- have two lines of defence at any point,
- not rely entirely on sealant,
- not unnecessarily bridge the cavity, and
- give water a means of escape when it does get in.

Details from WANZ, cladding suppliers, or bespoke solutions may be used. In the case of bespoke solutions, it is critical that the intersection of the different elements is considered holistically, particularly at the critical head/jamb flashing intersection. Changing one element of a proprietary solution may have unconsidered ramifications on the performance of other elements.

9

External Moisture Penetrations

This section should be read in conjunction with 6 External Moisture Overview and 8 External Moisture Flashings.

A penetration is any hole cut in a roof or wall cladding to accommodate projections such as pipes, ducts, chimneys, roof lights doors and windows.

This section focusses on roof penetrations only. The type of penetration design is determined by:

- the size of the hole,
- shape,
- the roof pitch,
- the type of roof,
- the catchment area,
- placement on the roof, and
- aesthetic requirements.

Designers are urged to consider what type of penetration design matches the building application and their customer's needs, and detail accordingly, rather than allow the installer to make an on-site decision.

Many of the penetration details drawn in the Code of Practice (COP) are included in a step by step *How -To Guide* published by the Roofing Association of New Zealand. A copy of this may be obtained by contacting info@roofingassn.org.nz.

9.1 Penetrations Minimum Pitch

Penetrations may be executed in roofs of any pitch down to the minimum pitch allowed for that profile. Penetrations are allowed in the portion of curved roofs where the pitch falls below these limits, providing the penetration flashing bridges the apex and terminates where the pitch is a minimum of 3°.

9.2 Additional Support

Terminating a sheet above and below a penetration creates an end span situation and sheet support and fastener patterns should be checked accordingly, or additional support must be provided. (See [3.5.1.1 Continuity](#).)

Penetrations requiring removal of a roof section greater than 300 mm x 300 mm require additional supporting framework. Ideally this should be in position before the roof cladding is fixed; alternatively, the supporting framework should be in position before cutting a hole in the cladding.

The additional support for larger penetrations must have the same strength as the adjacent purlins. Purlins and the support structure must be designed to take the additional weight of any plant exceeding 100 kg. Structural members must not be removed without engineering calculations.

9.2.1 Penetrations Safety

The person who cuts a hole greater than 600 mm x 600 mm in the roof is responsible for safety precautions, preventing workers from falling through the gap. A hole of this size is regarded as a hazard under the Health and Safety in Employment Act.

9.3 Penetration Durability and Compatibility

All fittings and materials above a penetration must be made from compatible materials and there must be no runoff onto the roof from incompatible materials or corrosive discharge.

Condensate and outflow from any sources such as air conditioning units, solar units or hot water pipes must not be discharged onto metal roof cladding but must be separately drained to an inert gutter or downpipe.

Level back curbs will not have the same durability as arrowhead or cricket designs and may require maintenance of the coating to match the durability of the roof cladding.

9.4 Penetration Design

It is the designer's responsibility to select the type of penetration flashing appropriate to the design requirements and the client's expectations. Penetrations can be broadly put into two categories: Sheetmetal flashings and Boot flashings.

The positioning of the penetration in relation to the apex, eaves and other architectural features must be taken into consideration when selecting the type of flashing to be employed.

9.4A Recommended Penetration Type Positioning

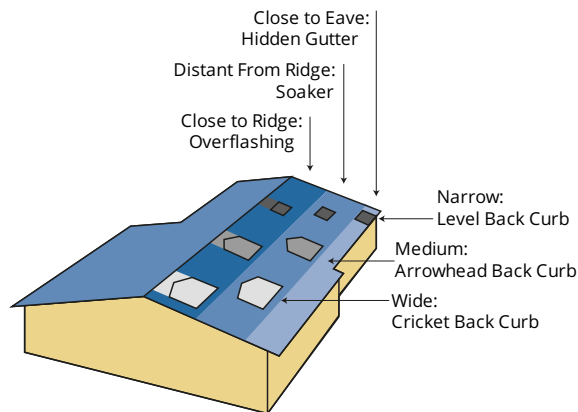

9.4.1 Sheetmetal Penetration Back Flashings

The first decision should be the back flashing, should it be over the profile [9.4.1.1 Over-Flashed \(Watershed\) Back Flashings](#) or under the profile [9.4.1.2 Under-Soaker Back Flashings](#).

9.4.1.1 Over-Flashed (Watershed) Back Flashings

Watershed back flashings are easy to install and to weatherproof, particularly if the roof is already in place. The drawbacks are their limits in width and, sometimes, noise or condensation issues. Long lengths of watershed flashings may require multiple end laps which are vulnerable to leakage. Where there are end laps or foot traffic is expected on the watershed flashing, the flashing must be supported in the pan or the profile by rigid closed cell foam or similar.

In many residential cases where the flashing is visible, the aesthetic values of watershed flashings may render them inappropriate for this application, unless the penetration is situated close to the apex.

The maximum width of a watershed flashing is controlled by the coil width of 1.2 m. The practice of making wider watershed flashings by running flashings horizontally with laps at 1.1 m is not acceptable, as the numerous joints are prone to leakage. Wider watershed flashings can be fabricated using longitudinal standing-seam techniques on suitable support.

9.4.1.2

Under-Soaker Back Flashings

Soaker back flashings are visually attractive and are less prone to noise or condensation issues. They are relatively easy and economical to install at the time of roof laying, but more difficult and costlier if post installation is required.

9.4.2

Curb Design

Curb design (i.e., level, arrowhead, or cricket) depends largely on the penetration width and the expected amount of debris, e.g., tree leaves. Proximity to the apex determines penetration flashing design (i.e., over flashing, under-soaker, or hidden gutter).

9.4.2.1

Level Back Curbs

Level back curbs are the most common solution for flashing penetrations and are the easiest to fabricate and install.

They may tend to collect debris as they have little or no transverse fall, which can limit durability. However, with normal maintenance when manufactured from the same material as the roof they should achieve the durability requirements of the NZBC.

For penetrations wider than 600 mm, or those in aggressive environments or in situations where maintenance is difficult, a freer draining design such as an arrowhead or cricket is preferable.

9.4.2.2

Arrowhead Back Curbs

Arrowhead back curbs have a diverter that provides transverse fall for diverting rainwater, enabling them to accommodate bigger catchment areas and self-cleanse. They have a small flat area at the base of the arrowhead that may require maintenance.

9.4.2.3

Cricket Back Curbs

Cricket back curbs divert water with less turbulence than either arrowhead or flat back curbs and have no flat areas to catch debris. They may be fabricated from the same material as the roof or welded from 1.6 mm aluminium and powder-coated to match the roof colour, to give a durable and matching solution. One-piece welded flashings offer the most durable and weathertight solution to penetration back curb.

9.4.2.4

Sheetmetal Penetration-Flashings Reference

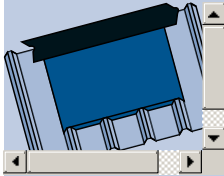
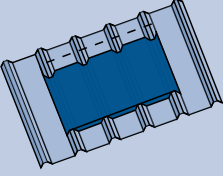
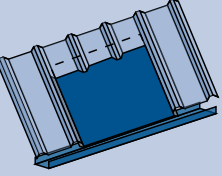
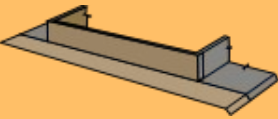
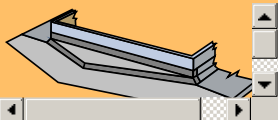
		Proximity to the apex determines back flashing design		
		Close to apex Over-Flashing	Distant from the ridge Under-Soaker	Adjacent to the Eave Hidden Gutter
				
		<ul style="list-style-type: none"> • Aka Dry pan or Watershed • Suitable for retrofitting 	<ul style="list-style-type: none"> • AKA Tray • Best solution for mid-roof penetrations 	<ul style="list-style-type: none"> • Only practical for penetrations located neat the eaves
Penetration width and debris determine curb design				
Narrow/Little Debris		Level	<p>Corrugated - 9.4.2.5A</p> <p>Trapezoidal - 9.4.2.6A</p>	<p>Corrugated - 9.4.2.5B</p> <p>Trapezoidal - 9.4.2.6B</p>
				
<ul style="list-style-type: none"> • Only suitable for small catchments not prone to leaf debris. • Relatively easy to manufacture on site 				
Medium/Moderate Debris		Arrowhead	<p>Corrugated - 9.4.2.5C</p> <p>Trapezoidal - 9.4.2.6C</p>	<p>Corrugated - 9.4.2.5D</p> <p>Trapezoidal - 9.4.2.6D</p>
				
<ul style="list-style-type: none"> • A diverter is formed by joining two trays into the shape of an arrowhead on site. • Suitable only for small catchments not prone to leaf debris. • Parts can be pre-ordered and final fitting done on site 				

Wide/Much Debris

Cricket

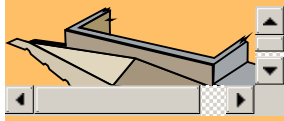

- Most suitable for larger catchment areas.
- Requires careful calculation and off-site fabrication.

Corrugated -
9.4.2.5E

Corrugated -
9.4.2.5F

Trapezoidal -
9.4.2.6E

Trapezoidal -
9.4.2.6F

9.4.2.5

Sheetmetal Flashings on Corrugated Profiles

9.4.2.5A Level Over-Flashing: Corrugate

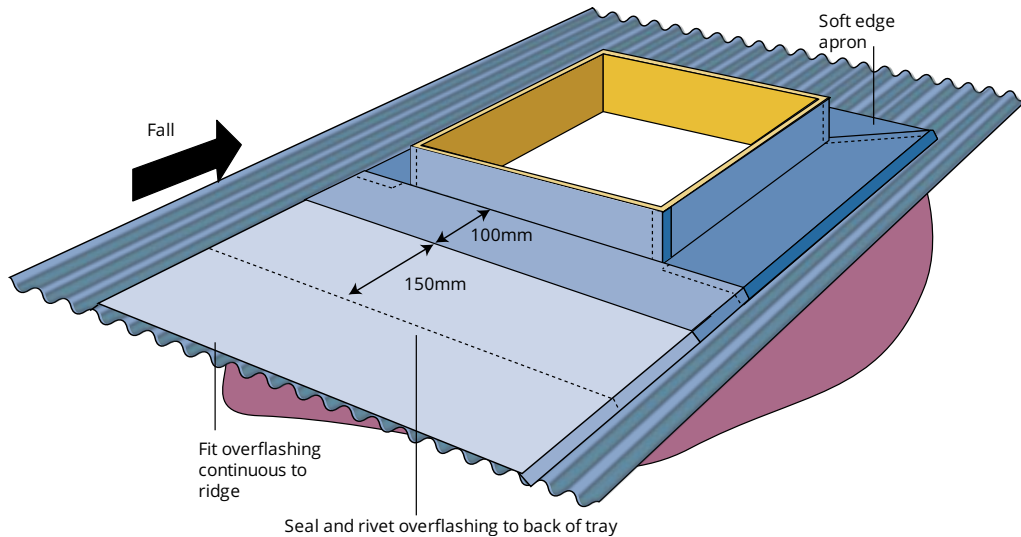

9.4.2.5B Level Under-Soaker: Corrugate

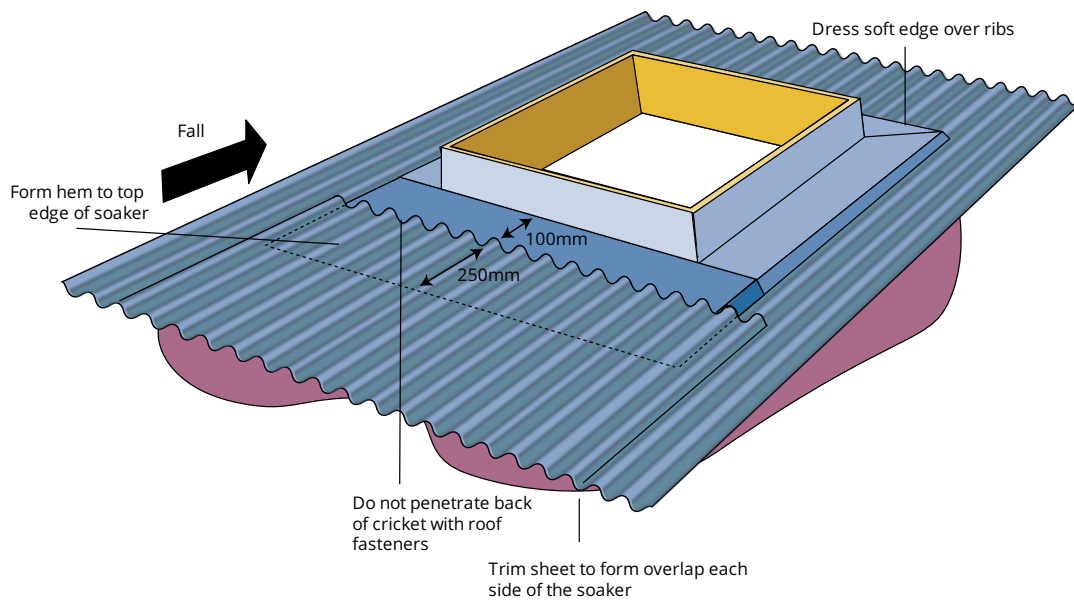

9.4.2.5C Arrowhead Over-Flashing: Corrugate

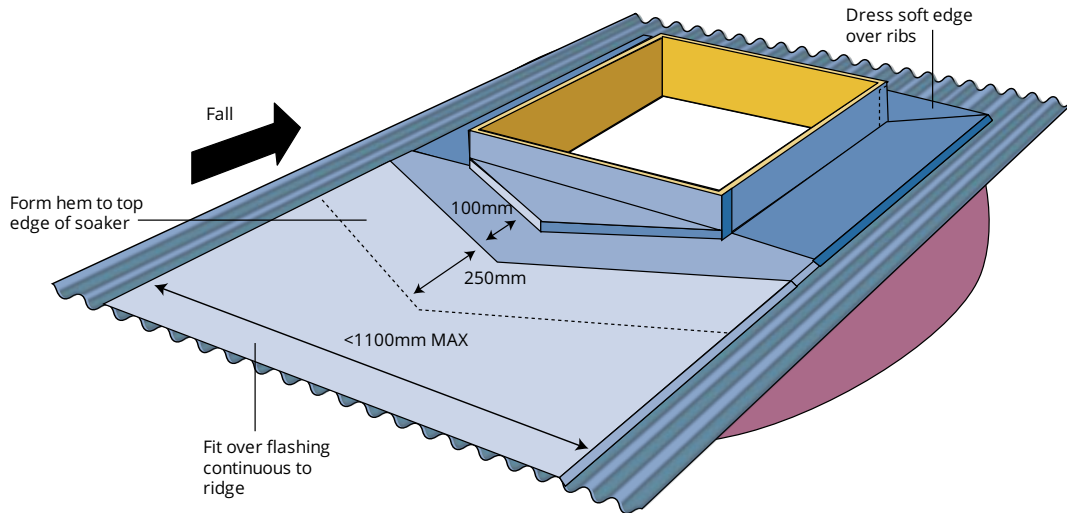

9.4.2.5D Arrowhead Soaker: Corrugate

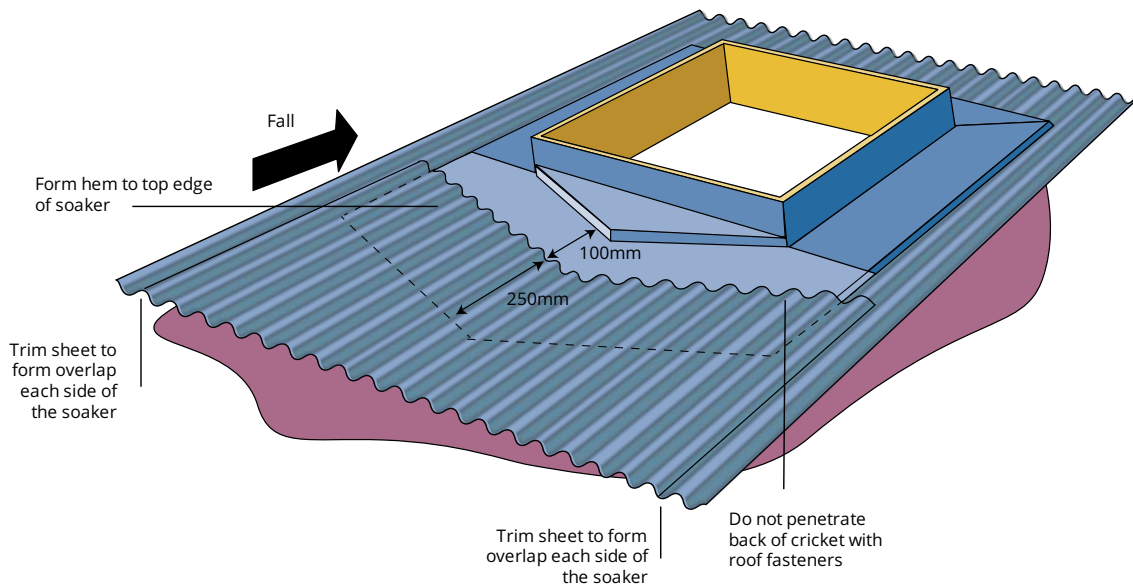

9.4.2.5E Cricket Over Flashing: Corrugate

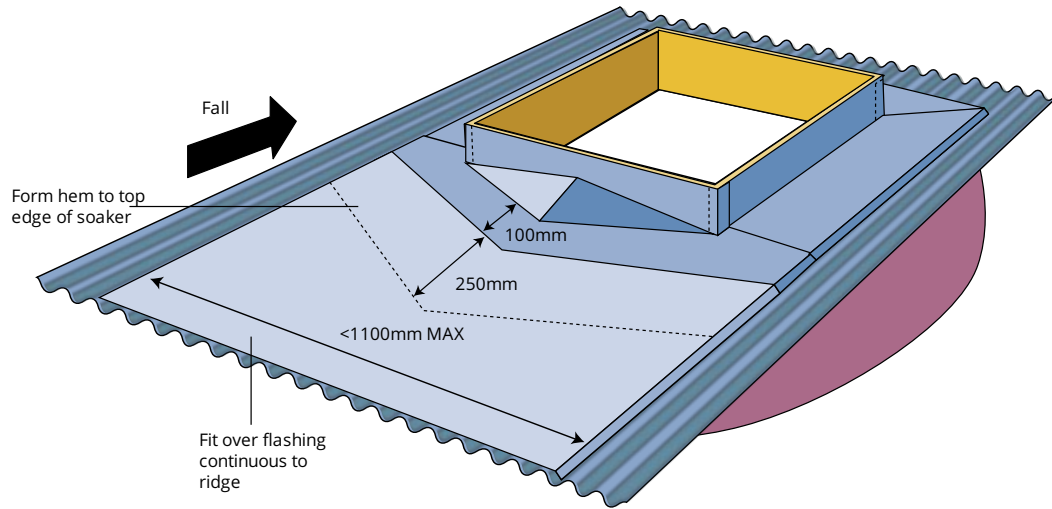

9.4.2.5F Cricket Under-Soaker: Corrugate

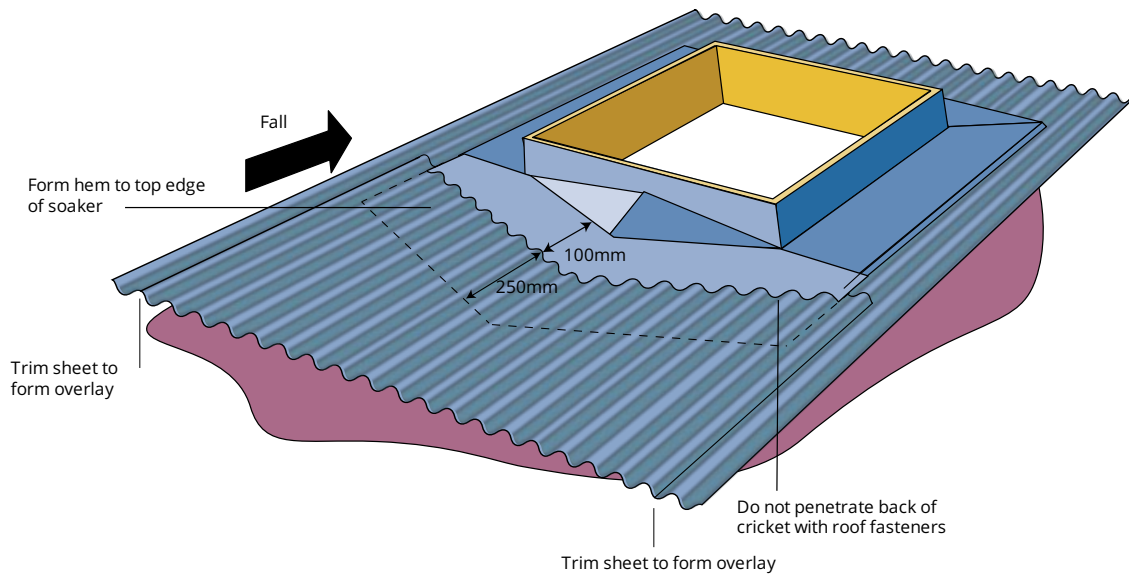

9.4.2.5G Level Hidden Gutter: Corrugate

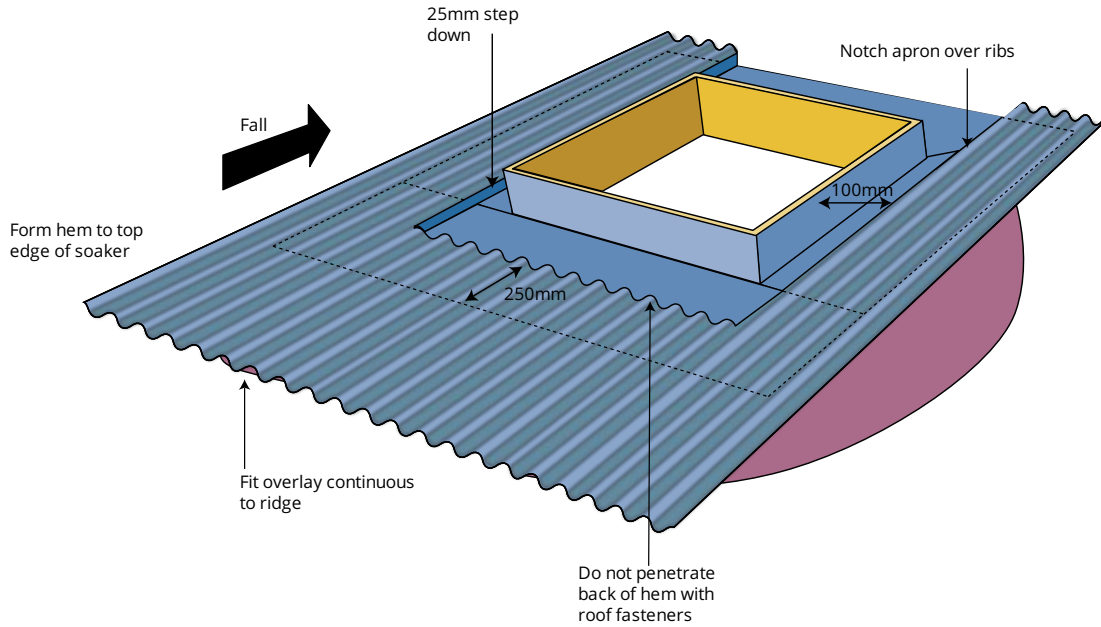

9.4.2.6 Sheetmetal Flashings on Trapezoidal Profiles

9.4.2.6A Level Over-Flashing: Trapezoidal

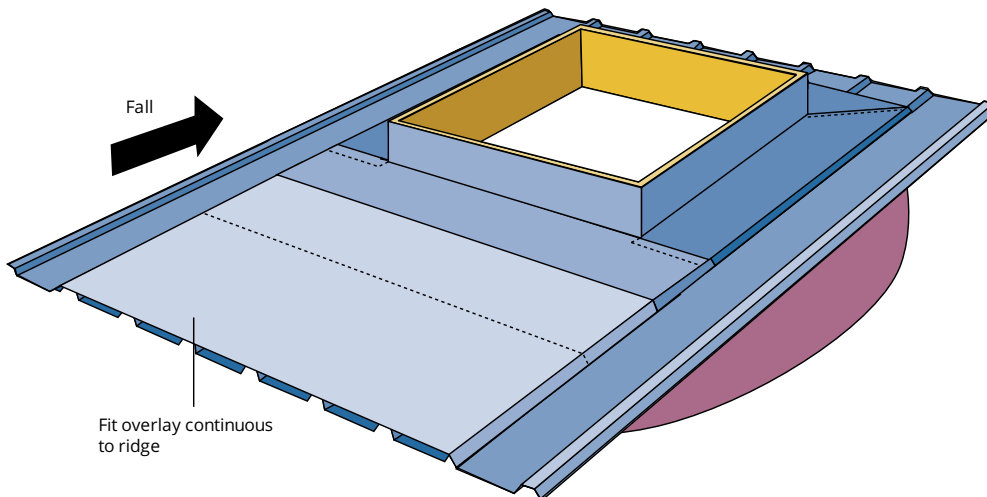

9.4.2.6B Level Under-Soaker: Trapezoidal

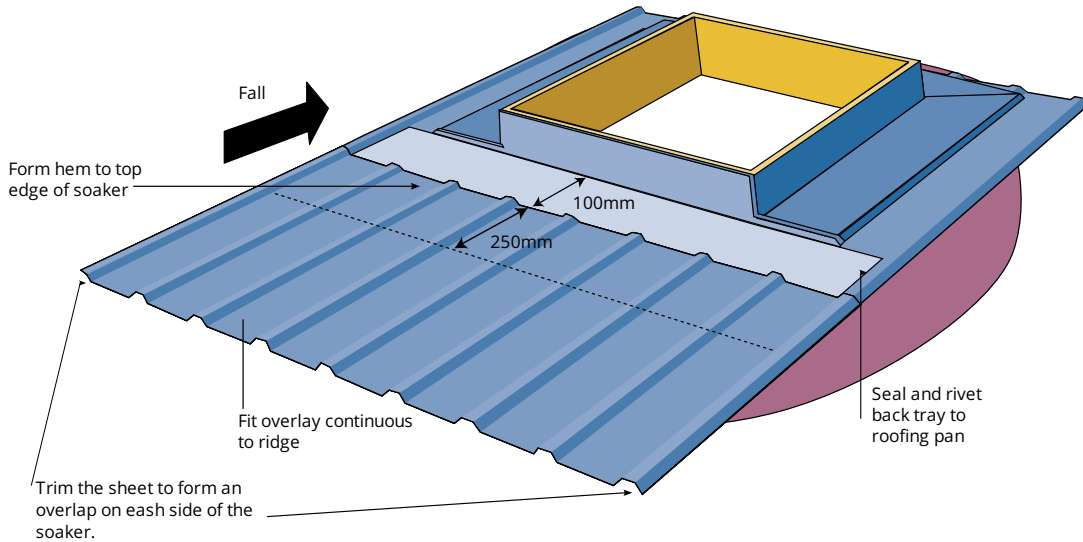

9.4.2.6C Arrowhead Over-Flashing: Trapezoidal

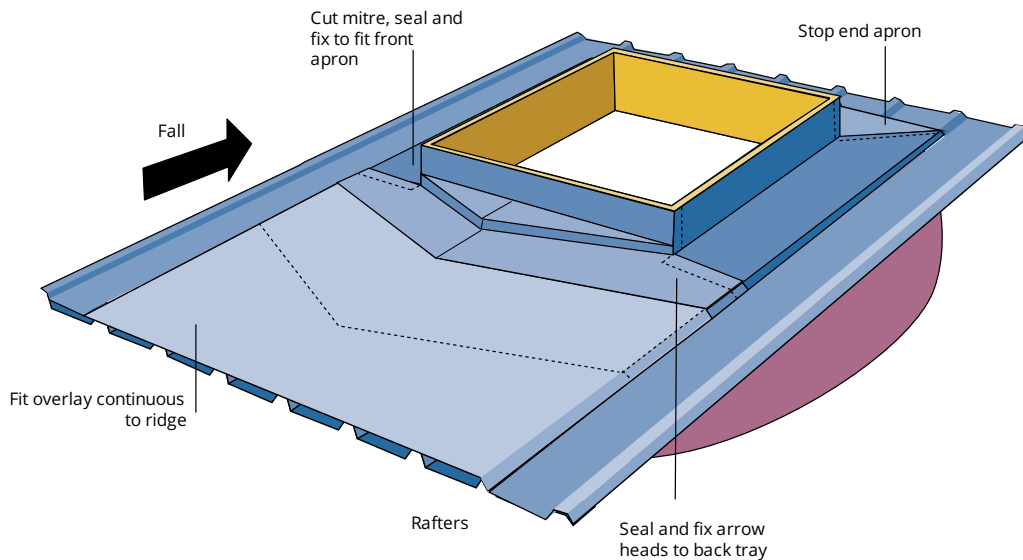

9.4.2.6D Arrowhead Under-Soaker: Trapezoidal

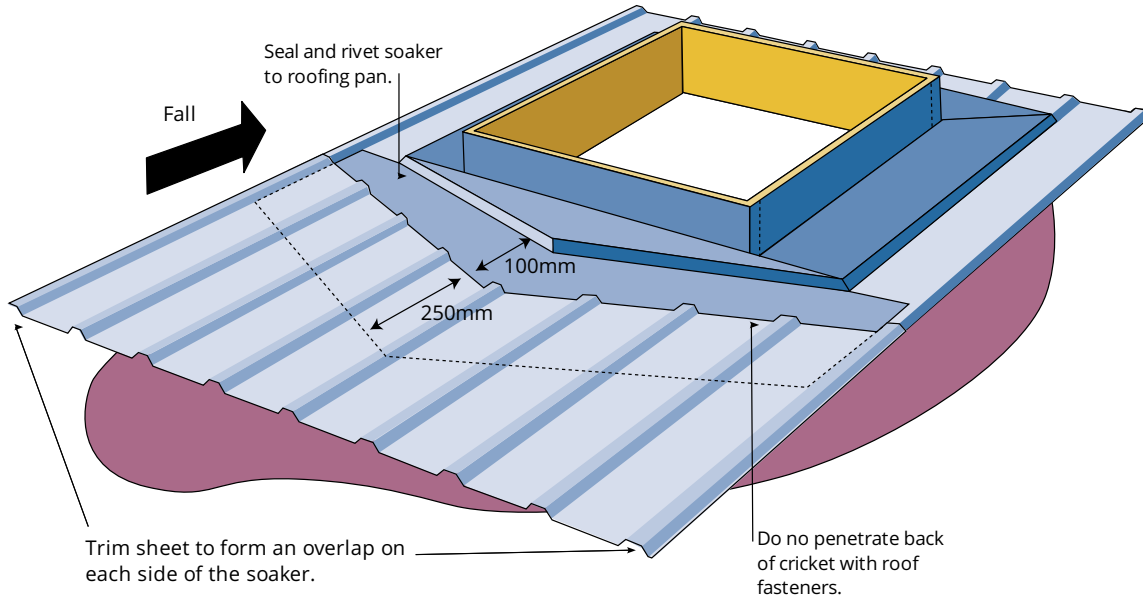

9.4.2.6E Cricket Over-Flashing: Trapezoidal

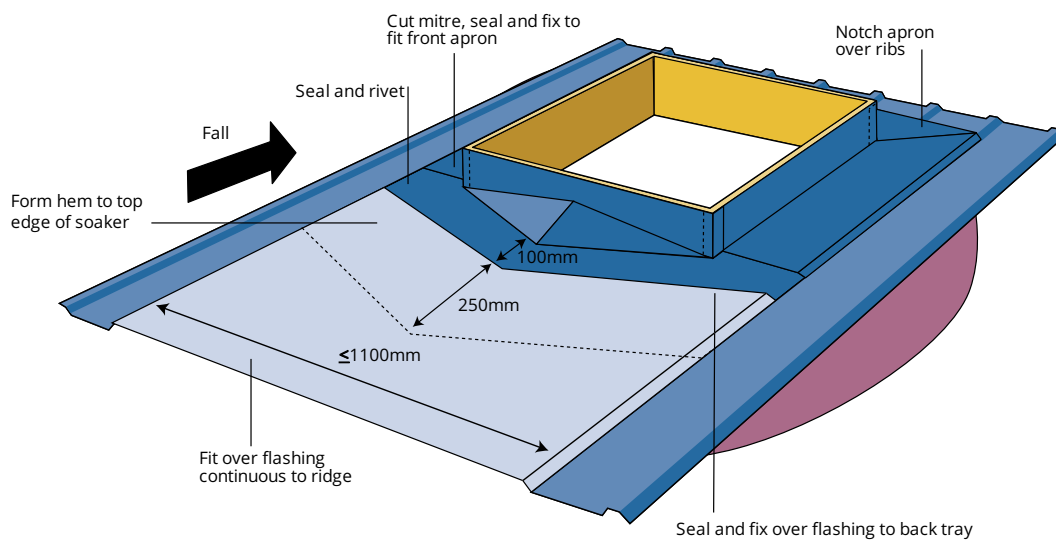

9.4.2.6F Cricket Under-Soaker: Trapezoidal

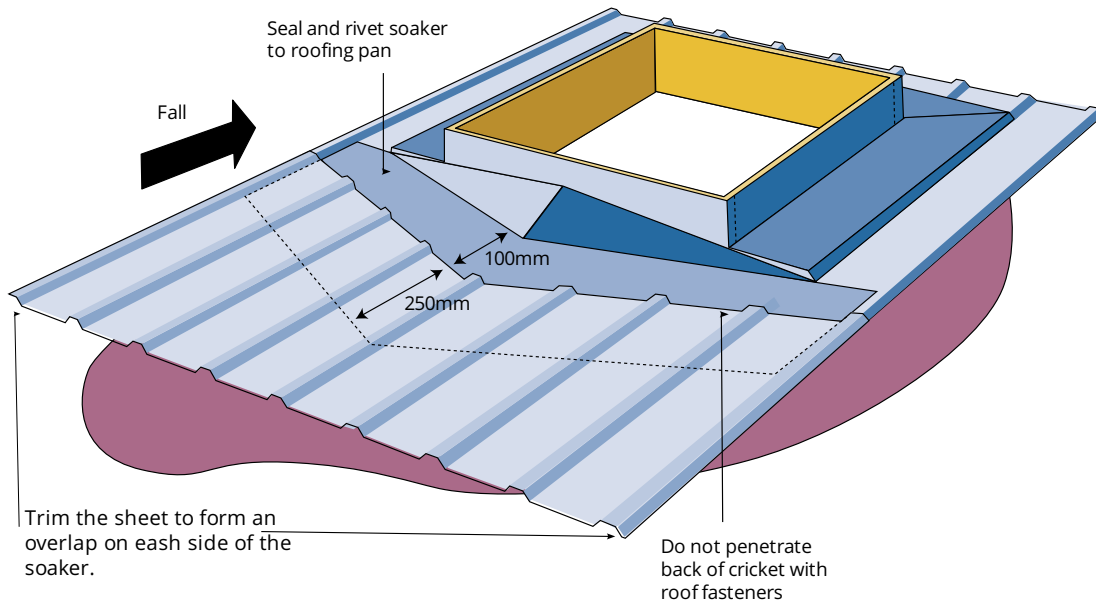

9.4.2.7 Cricket Over-Flashing More Than 1 m Wide

9.4.2.7A Details for Large Cricket Over-Flashing

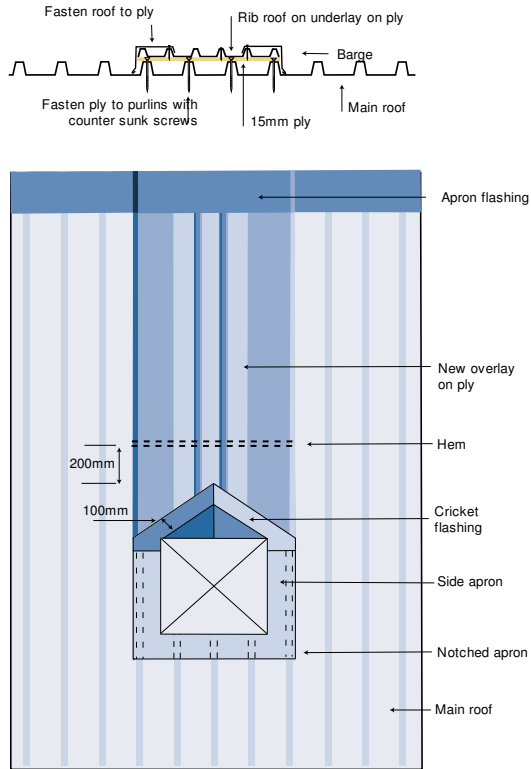

9.4.3 Dormer Details

9.4.3A Gable Dormer

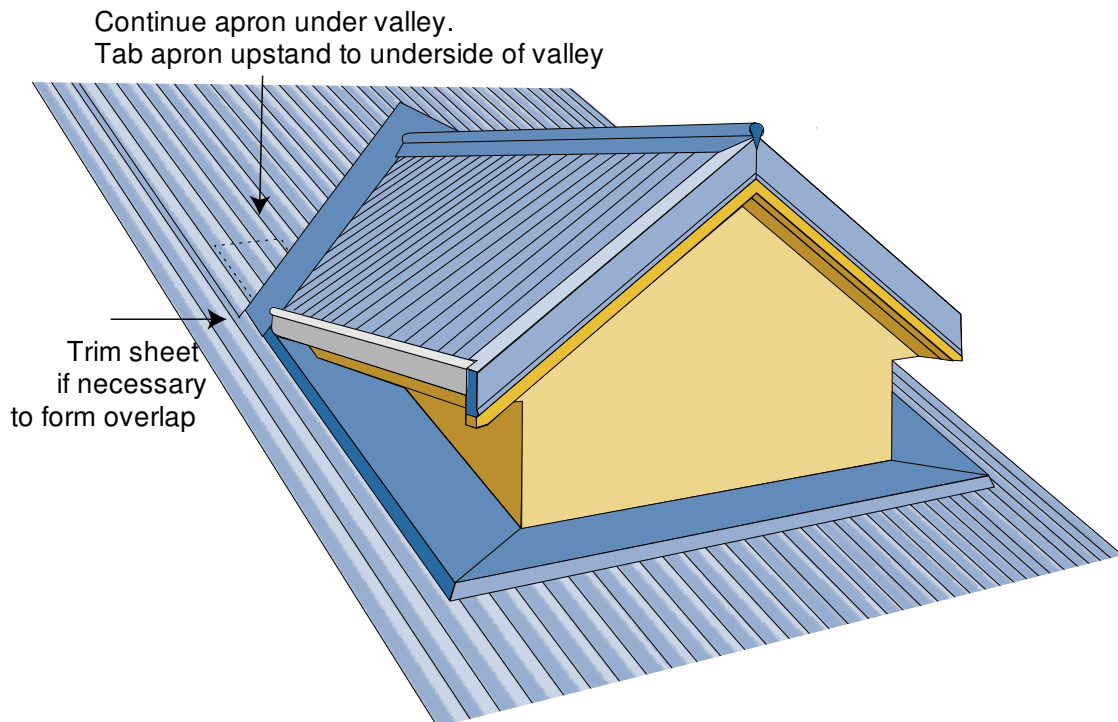

9.4.3B Gable Dormer Valley: Corrugate

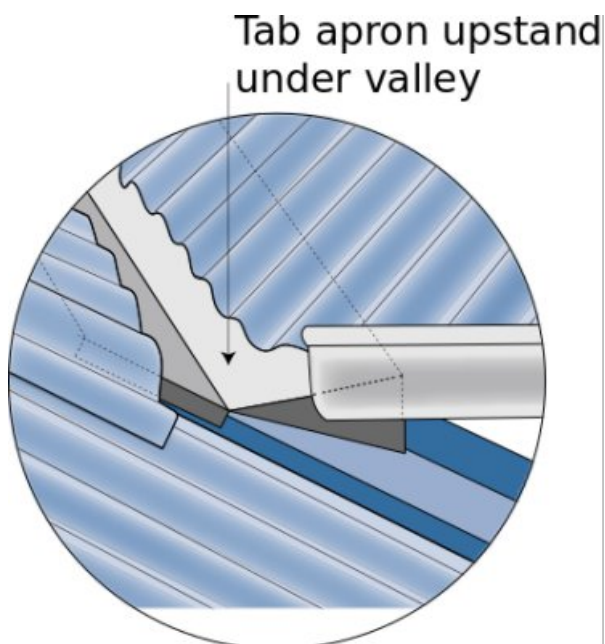

9.4.3C Gable Dormer Valley: Trapezoidal

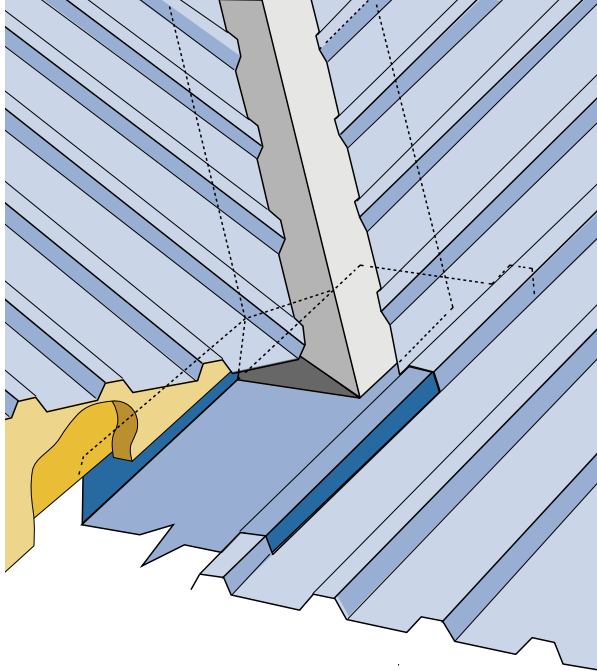

9.4.3D Gable Dormer Valley-Apron Junction

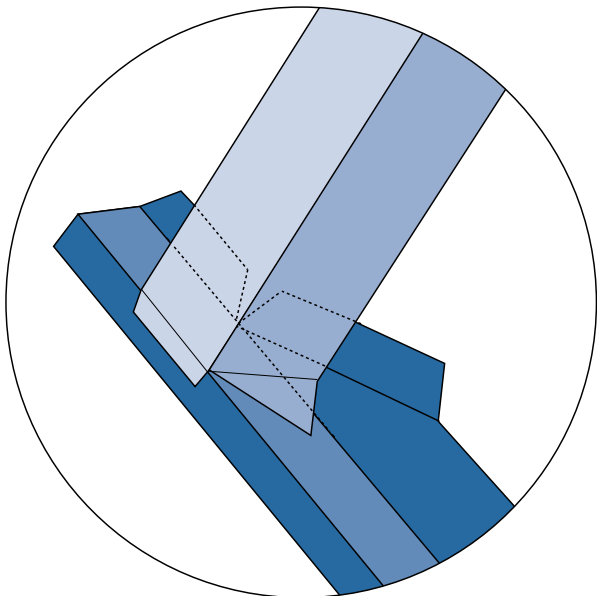

9.4.4

Maximum Area Above Penetration Calculator

A responsive online tool for calculating Maximum Area Above Penetrations is available at <https://www.metalroofing.org.nz/maximum-area-above-penetration-calculator>.

9.5 Boot Flashings

A boot flashing is a proprietary EPDM flashing designed to weatherproof cylindrical penetrations protruding from a roof or wall. The top is trimmed to form a tight weatherproof collar around the penetration, and the base is formed with a series of concentric rings to the underside and a malleable stiffener of aluminium which is dressed to conform to the shape of the roofing profile. It is generally top-fixed to the roof surface with screws or rivets, and sealant.

The Profiled Metal Roofing COP allows pipe penetration flashings to be fitted directly to the profile or on to an over flashing. Pitch limitations depend on the method used and the cladding profile.

Direct-fixed options are pitch sensitive. When laid directly on to the profile at too low a pitch, they will entrap water rather than allow it to discharge over the profile crests that they traverse. The practical limits of direct-fixed boot flashings that cross an entire pan are 8° for standard corrugated and 10° for low rib trapezoidal products. Where the base of a boot does not obstruct a pan it can be direct-fixed to the minimum pitch for that profile.

Direct fixed applications for high rib trapezoidal profiles and trough sections vary according to the profile, and the size and position of the penetration. For these applications, the manufacturer should be consulted or the flashing can be attached to an over flashing, or a top fixed soaker type can be used.

Where the penetration is wide such as a chimney flue casing, and the penetration is far from the apex, soaker flashings may be used where the profile ribs are cut back so water can divert into the adjacent pan.

Where overall width is not a constraint, directly fixed boot flashings should be installed with their edges diagonal to the fall of water. Where this is not practical, they may be laid square at pitches of 10° or more.

9.5A Square-Fixed Over-Fitted Boot

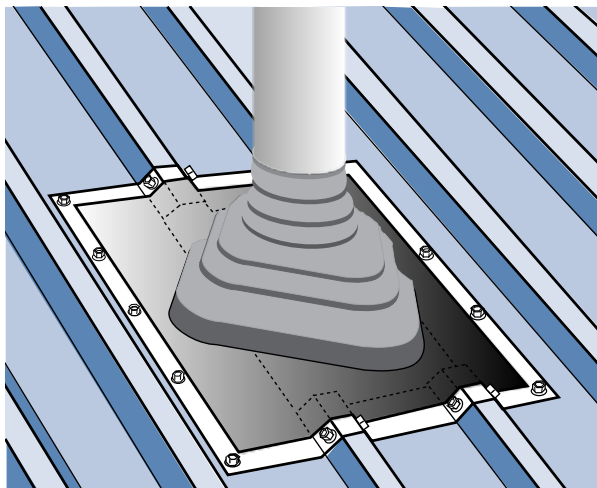

Where boot flashings traverse a lap, the lap must be fully sealed or other actions must be taken to avoid leaks through capillary action. Where possible the fixing of a boot flashing over a lap should be avoided

The vertical sections of a boot flashing must not constrict the free flow of water. Where more than 50% blockage of the pan occurs other penetrations must be considered, or catchment calculations of the capacity of the remaining pan area should be made. (See [5.4.7 Gutter Capacity Calculator](#))

9.5B Direct-fixed Boot on Trapezoidal Profiles

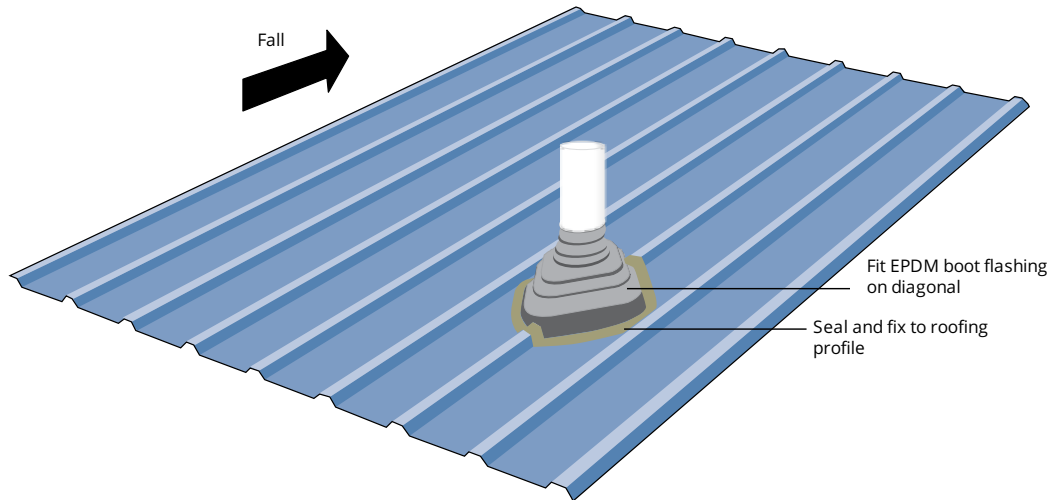

9.5C Direct-fixed boot on Corrugated Profiles

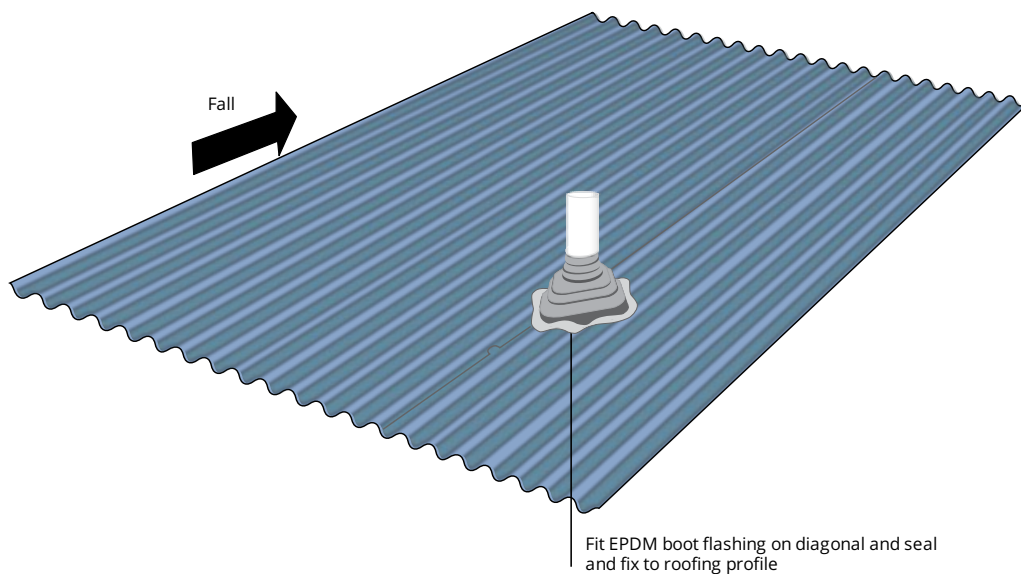

9.5.1 Boot Flashings to an Over Flashing

Boot flashings fitted to an over flashing are acceptable at pitches down to the minimum of that allowed for the profile. Typically, this is 8° for standard corrugated, and 3° for trapezoidal and trough sections. These boot flashings must be fixed diagonally to the fall of the roof at pitches below 10°.

Over flashings can be continuous to the apex, or terminate with a soaker at the upper edge.

9.5.1A Over-Flashed Boot Flashing on Corrugated Profile

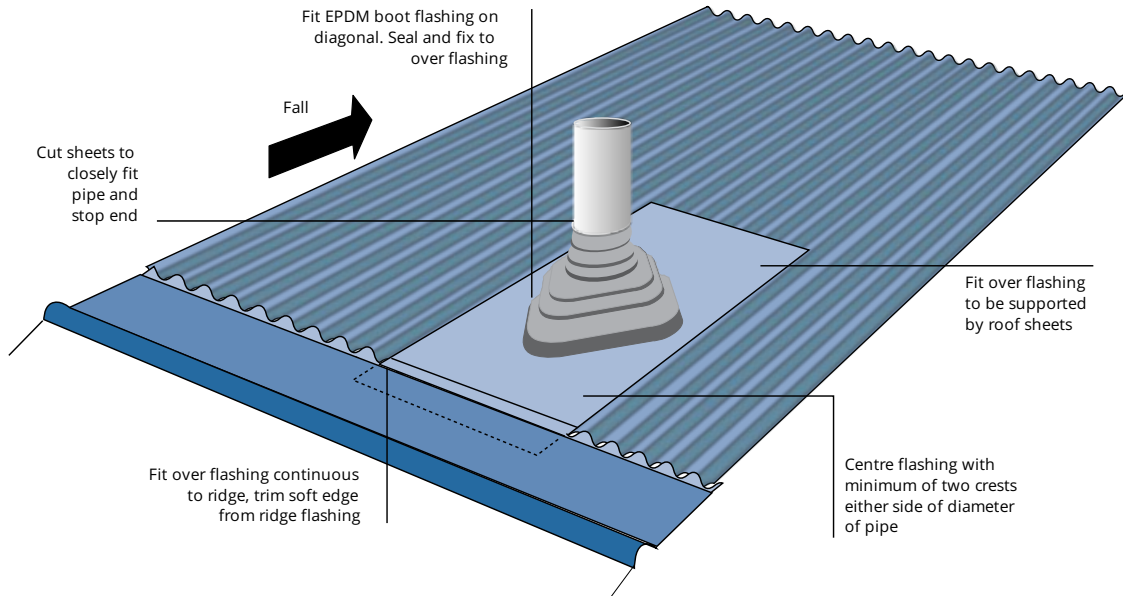

9.5.1B Over-flashed Boot with Soaker Level Curb on Trapezoidal Profile

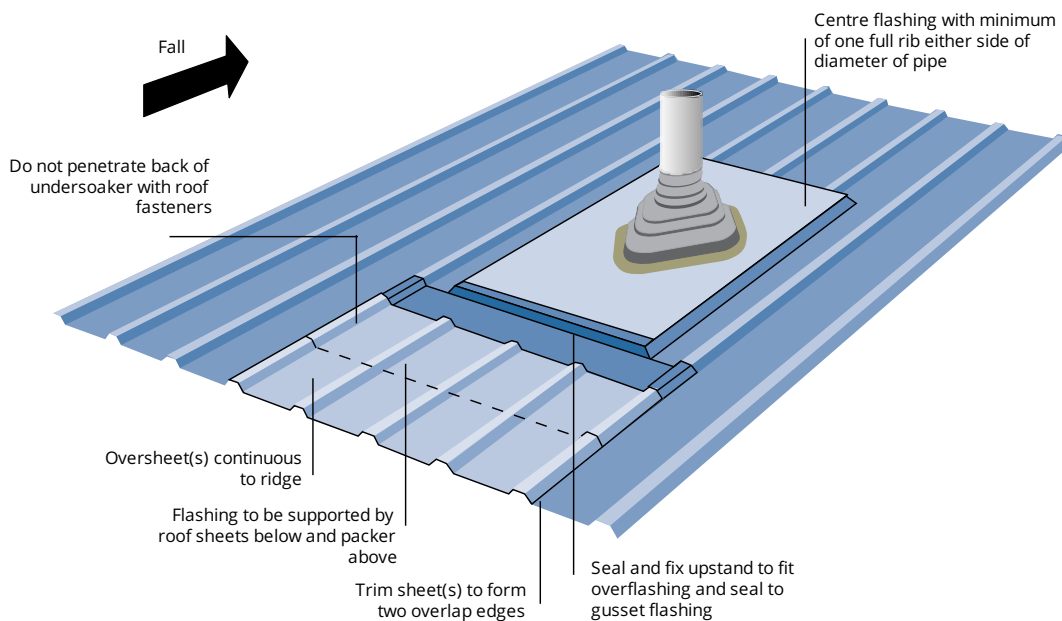

9.5.1C Over-flashed Boot with Arrowhead Soaker on Trapezoidal Profile

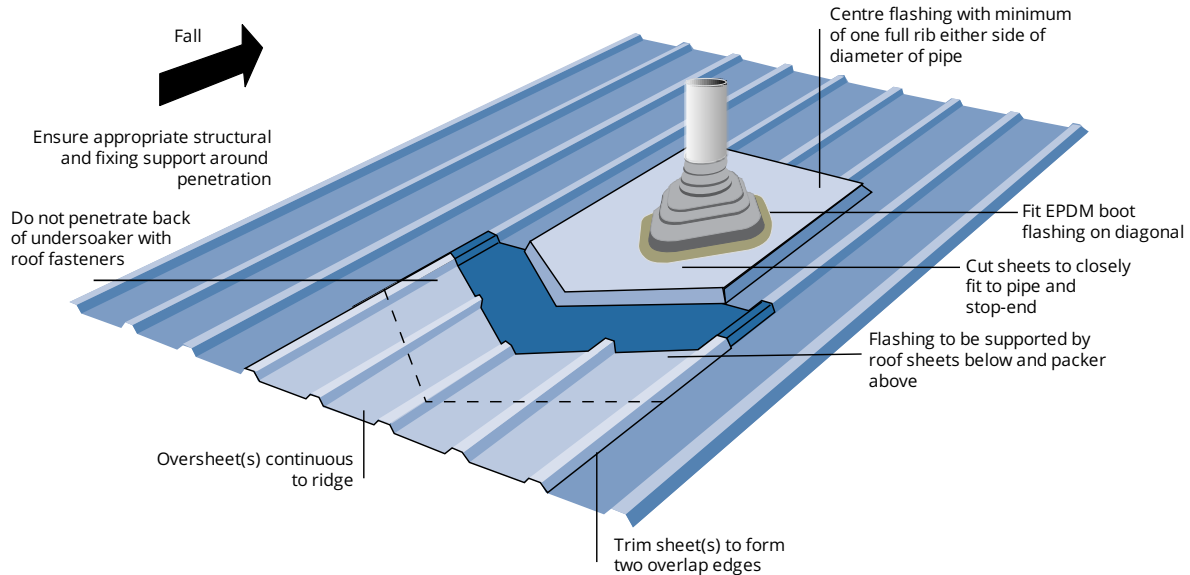

9.5.2 Other Applications for Boot Flashings

9.5.2.1 Plant Room And Conduit Penetrations

Where flexible power conduits or telecommunication cables are required to penetrate the roof cladding, accessibility can be improved by using P.V.C pipe fittings and an E.P.D.M. flashing to weather a number of conduits.

Cable penetration flashings must be goose-necked. It is not acceptable to exit cables through a vertical flashing such as a boot flashing where sealant is the only barrier to water leakage.

9.5.2.1A PVC and E.P.D.M Flashing

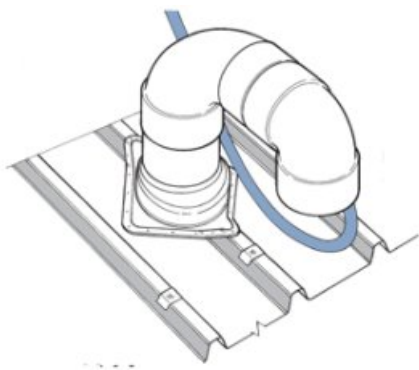

This flashing should be fixed next to the purlin for support.

Safety bollards for fall arrest anchorages are required where regular maintenance is required, and these can also be weathered by E.P.D.M. flashings.

9.5.2.2 Mechanical Services

Where plant room supports are required to penetrate the roof cladding, the designer should provide the support framing from Circular Hollow Sections (CHS) in preference to Rectangular Hollow Sections (RHS) or other hot rolled steel sections, because it is easy to flash the CRS with E.P.D.M. flashings. This procedure allows the E.P.D.M. flashings to be slid over the pipe framing during erection, and avoid the necessity of using retrofitting types.

The support framing should be in place, but below the top of the purlin, before installing the roof cladding. That allows the cladding installation to proceed without having to weatherproof multiple penetrations at the same time.

9.5.2.2A Support Framing

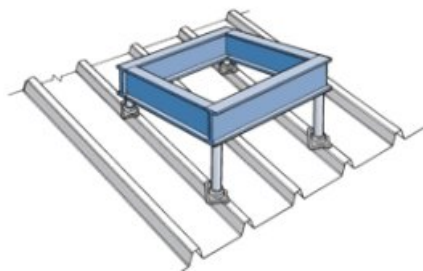

(optional caption)

Proprietary support systems are available for lightweight support through to the purlins.

9.5.2.2B Lightweight Support Frame

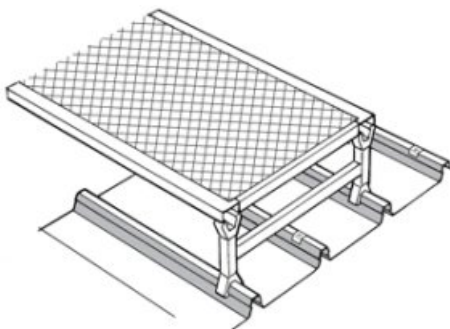

These types of supports provide clearance for cleaning but should not create an unwashed area underneath them.

9.5.3

Flush Penetrations

Penetrations such as roof window may be mounted flush with the crests of the roofing profile. In such cases, the side flashing onto the roof shall be the same as required for a barge cover. The flashing termination onto the roof window shall be as per window manufacturers requirements

10

Internal Moisture

The science of internal moisture control is concerned with the need to manage and control condensation, mould growth, and corrosion.

The outdoor environment, the building design, and occupant behaviour affect humidity in the living spaces, which ultimately affects humidity in the ceiling space.

This section of the COP focusses predominantly on managing humidity in the ceiling space of dwellings. Shorter sections also cover the design of non-residential roof and wall cladding, which may also be affected by excessive internal moisture.

10.1 NZBC Clause E3: Internal Moisture (Extract)

Source: Acceptable Solutions and Verifications for New Zealand Building Clause E3 Internal moisture.

10.1.1 E3 Objective

Safeguard people against illness, injury, or loss of amenity that could result from the accumulation of internal moisture.

10.1.2 E3 Functional Requirements

Buildings must be constructed in a way to avoid the likelihood of:

- *fungal growth on linings and other building elements, and*
- *damage to building elements due to the presence of moisture.*

10.1.3 E3 Performance Requirements

NZBC Clause E3 requires building practices to ensure an adequate combination of thermal resistance, ventilation, and space temperature in all habitable spaces, bathrooms, laundries, and other spaces where moisture may be generated or accumulate.

10.1.4 Compliance

New Zealand Building Code clauses E3 – Internal Moisture and G4 – Ventilation focus on air quality and accumulation of moisture in occupied spaces. The acceptable solutions for these clauses do not specifically require ventilation of attic spaces.

While problems with excessive internal moisture in attic spaces are relatively uncommon, they can be severe. A poorly designed ceiling cavity, even above a well-aired room, can give rise to internal moisture problems in the attic space, which can affect the air quality of the occupied space below and may cause health and durability issues.

The COP requires building techniques which encourage trickle ventilation of all spaces in buildings; and requires specific ventilation design for:

- flat roofs,
- sarked roofs,
- skillion roofs, and
- roofs with ceilings which allow easy passage of moisture vapour.

Long (over 12 m spans), shallow pitched (less than 12°) roofs should also be designed to allow natural ventilation.

Generally, there is no need to make provision for moisture control in industrial and most commercial buildings due to them being either well ventilated or climate controlled. In buildings with valuable or delicate stock, the possibility of dripping condensation needs to be assessed.

Roofs in cold areas where numbers of people may come in wet at the end of the day, such as ski lodges and tramping huts, require specific design.

Buildings designed to accommodate large numbers of people (such as theatres, sports areas and educational buildings) and areas creating particularly high moisture levels (e.g. swimming pools) should have ventilation solutions designed by a specialist engineer.

10.2 Why Manage Internal Moisture

Internal air quality is a major cause of respiratory illness, which has been reported as costing the country \$6 billion per annum, with respiratory-related illnesses accounting for one in ten of overnight hospital admissions.

Dust mites grow up to ten times faster in damp environments and contribute to allergic reactions and asthma.

The most recent BRANZ Home Condition Survey identified mould ranging from moderate to severe in 22% of New Zealand houses. Mould was worst in rental accommodation, where much of our most vulnerable population live.

In addition to the health effects, excessive internal moisture impacts material durability. In the roof space, this can affect the roof cladding, underlay, purlins, trusses, fasteners, and seriously affect the durability and structural integrity of those components without being apparent to the occupants.

10.3 Special Requirements

Buildings of the following types using metal cladding should have a sealed vapour barrier and are outside the scope of this Code of Practice. They require specific design.

- Swimming pools.
- Buildings containing liquids stored in open containers.
- Buildings where water is used in manufacturing, cleaning or storage processes.
- Ice rinks, cold stores and freezers.
- Buildings where unvented gas heating is used.

10.4 Condensation

Condensation is a natural phenomenon and building materials are capable of withstanding repeated short-term episodes of wetness. Problems arise in ceiling spaces when more water vapour enters than exits, and materials stay wet for long periods, or where standing water accumulates.

The primary purpose of roof cladding is to act as a rain screen so that no water enters the building from the outside. It is, however, equally important to ensure that the building is kept dry from inside. Because metal is a good heat conductor and is not absorbent, condensation forms on metal cladding under conditions of high humidity when surface temperatures drop below the dew point.

The solutions in the Code of Practice apply to cold roofs, where there is a gap between the ceiling insulation and the roofing material. [10.12.2 Warm Roofs](#) require specific design to avoid internal moisture problems. They are discussed in more detail under [15.5 Warm Roofs](#).

10.5 Building Airtightness

10.5A NZS 3602:1975 (Lapsed)

24.2.3 *Roof cavities*

24.2.3.1 Roof cavities, including cavities beneath flat roofs, should be ventilated by such means as:

- (a) Grilles in eaves;
- (b) Louvre frames in gables;
- (c) A continuous gap in the roof soffit;
- (d) Ventilating ridging; *or*
- (e) Other suitable means.

Changing building techniques and materials – eg, impervious cladding and linings, and aluminium joinery – have led to buildings becoming progressively more airtight. Many of these changes have been led by the desire to increase energy efficiency. Other building changes include unsealed downlights, which can allow ready entry of water vapour into the ceiling space, and the demise of the open fireplace which provided considerable ventilation to the living areas of a home.

Occupant behaviour has also changed. More families shower daily and then leave the house unoccupied and closed-up for much of the day and night. Less activity means a low level of air changes per hour.

These changes can lead to internal moisture problems. As water vapour is lighter than other atmospheric gases, much of the moisture tends to migrate upwards into the ceiling cavity.

10.5B BRANZ Survey showing changes in permeability on NZ houses over time

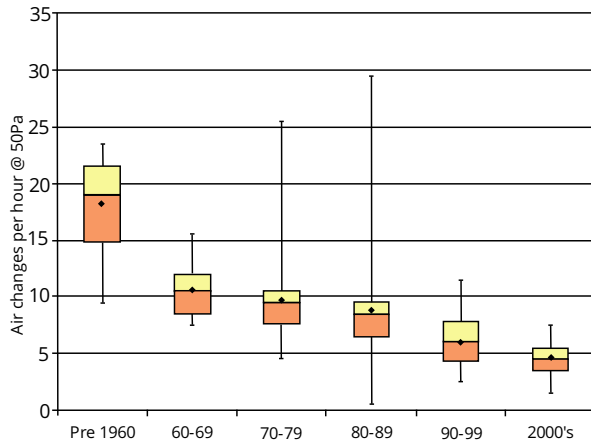

10.6 Insulation

The increase in ceiling insulation standards helps prevent heat leakage into the ceiling space, but it does not affect the passage of water vapour. Ceiling insulation excludes more heat from the ceiling cavity, resulting in colder cavity air temperatures. Warmer air can hold more water vapour than cold air. Therefore, colder temperatures in the ceiling cavity lead to an increased risk of condensation.

10.6.1 Insulation Position

Insulation must be positioned so that there is a gap of at least 20 mm between insulation and roofing. On flat ceilings, or buildings without eaves, it must be placed so the gap is maintained at the eaves or an eaves insulation barrier should be fitted. To achieve this, an eaves insulation barrier may be required.

10.6.2 Other Insulation

Reflective foils are not defined as insulating, because they are only somewhat effective against radiative heat loss and have little impact on conductive and convective mechanisms. They also increase the potential for electrocution. As they are non-absorbent, they are not permitted as residential roofing underlay in New Zealand.

When Polyester blanket insulation is used in conjunction with metal roof cladding, special roofing screws should be used to avoid binding.

Composite insulated metal panels are described in [15.5 Warm Roofs](#).

Insulation must not be laid over the purlins as this compromises the air gap and the efficiency of the insulation where the roofing compresses it.

10.7 Climate

Being narrow, mountainous, islands lying in the path of strong prevailing winds, New Zealand is subject to high rainfall and high humidity. Compared to much of the world – where 70% relative humidity is considered the threshold of corrosion and health problems – New Zealand has very high humidity, particularly in northern regions, where the mean annual humidity levels are often around 80% or more. This means the dew point (temperature at which condensation begins to form) is also higher than in colder but drier climates.

The design requirements to deal with this environment are specific to New Zealand, which is reflected in our building practices. It is not advisable to use design or installation practices from countries with different environmental conditions without a comprehensive assessment of the management of internal moisture under NZ conditions.

10.7.1 Humidity

Relative humidity (RH, given in per cent [%]), is the most widely known method: It gives the content of water vapour in the air relative to the maximum amount of water this parcel of air can hold at its present temperature.

Other measures are absolute humidity and water vapour pressure.

10.8 Moisture Sources

Everyday household activities, heating, indoor plants, pets and construction activities all contribute to indoor moisture.

10.8.1 Occupant Behaviour

The occupants of the building create a significant amount of water vapour. Therefore, the air inside in a building typically has a higher moisture content than the external atmosphere.

10.8.1A Everyday Activities Release Moisture Vapour

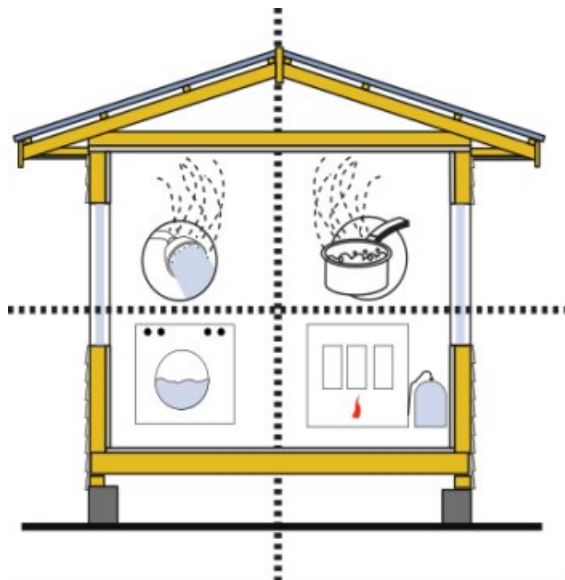

10.8.1B Approximate Amount of Water Vapour from Occupant Behaviour

Occupant behaviour	Estimated Amount of Water Released (per 2.5 inhabitants)
Cooking (unventilated)	3.0 L / day.
Baths / Showers	1.5 L/day.
Clothes Washing	0.5 L/ day.
Clothes drying (unvented)	5.0 L/ load.
Dishwashing	1.0 L / day.
Portable gas heater	up to 1.6 litres per 1kg of gas burned.
Breathing (average)	3 litres per day.
Breathing asleep (per hour) (average)	50 ml.
Perspiration	0.5 litre per day.
Pot Plants	The same amount as the input

Bathing and showering, cooking, heating, indoor laundries, and unvented clothes drying are the most obvious sources of water; respiration, perspiration, indoor plants, and pets also produce moisture.

Areas for moisture-generating activities should be well ventilated and the entire building should be mechanically ventilated to outside the structure. Proposed changes to NZBC G4/AS1 will require venting to the outside of appliances such as showers, baths, and cooktops.

10.8.2 Heating

Some other sources of moisture are best avoided altogether, particularly unvented gas heating and kerosene heaters. Burning 1 kg of gas can release 1.6 litres of moisture into the atmosphere.

10.8.3 Mechanical Venting

Supply-driven and exhaust-driven mechanical ventilation systems can pressurise or depressurise internal atmospheres in different areas of the building. Supply-driven systems can be problematic as increased internal pressures can drive moist air into the attic through openings in the ceiling.

Exhaust-driven systems can de-pressurise internal areas and increase the intake of moist external air, e.g. ground moisture via a vented cavity. Unbalanced mechanical ventilation can also encourage moisture migration by creating negative pressures in the ceiling cavity. These systems need to be well designed and maintained to avoid the risk of affecting internal moisture. A balanced mechanical ventilation system, where both intake and exhaust are connected to the outside, is the preferred system and will be most effective when the thermal envelope of the building is airtight.

10.8.4 Construction Moisture

During construction, timber can become wet and take some time to dry out. Some activities, such as plastering and painting, also release water vapour.

Concrete floors are particularly prolific sources of moisture. During curing, a 100 mm thick concrete slab releases approximately 10 litres of water vapour per square metre of surface area. The curing period depends on various factors, but as a rule of thumb, a concrete floor cures at a depth-rate of 25 mm per month. Therefore, a concrete slab can affect internal moisture levels for a considerable period.

All new buildings, particularly those with concrete floors, must be kept well ventilated (at much higher levels than required during normal use) until moisture levels of construction materials have stabilised.

10.8.4A Mould Damage



This building suffered mould damage to underlay and roof truss even before occupants moved in.

10.8.5 Ground Moisture

Ground moisture can infiltrate living spaces by way of the floor or directly to the ceiling space by way of vented cavities. The cavity should be constructed to prevent the migration of water vapour into the ceiling space. Wet subfloors can be isolated by laying polythene tightly over the surface and taping all joints. More information can be obtained from the *Good Repair Guide: Damp Subfloors (BRANZ)*.

Concrete floors must be installed over a damp-proof membrane (DPM) to ensure that moisture from within the ground does not penetrate the slab. This membrane can be formed by a polyethene sheet that is taped at the laps and laid over compacted hard fill topped by a sand blinding layer. The DPM must be installed under the full extent of the slab, under any internal or perimeter foundations, extend up to the external edge of the floor slab, and lapped and sealed under the wall damp-proofing system.

10.9 Minimising Ingress of Water Vapour into the Ceiling Cavity

The first line of defence for managing roof space moisture levels is maintaining low relative humidity in the dwelling areas. The second line is preventing excessive amounts of moisture entering the ceiling cavity. It is recommended that all ceilings are square stopped and all penetrations (cables, pipes, hatches, etc.) are caulked. Only use downlights that are airtight and have a gasket

A gloss painted plasterboard ceiling presents some resistance to the passage of water vapour but is not a complete barrier. Vapour will also find its way through any minor gaps in architectural details, and it is air transport through gaps that is responsible for 95% of the passage of water vapour into the ceiling space.

Ceiling tiles and tongue and groove ceilings are considerably more porous than plasterboard. Unsealed downlights can be a major source of moisture movement into the ceiling cavity and should be avoided where possible.

See [BRANZ Facts Roof Ventilation #3](#) .

In some older New Zealand homes, vapour barriers have been used to limit entry of moist air into the ceiling space, but control of air movement into the cavity and removal of damp air by ventilation is a more practical approach.

Cavity systems prescribed under E2AS1 9.1.8.1, except those behind masonry veneer, are classified as drained not ventilated. That means they must be closed at the top to restrict air movement between the cavity and the roof space. Closing a cavity off at the top still allows reasonable ventilation of the cavity while preventing excessive amounts of moisture rising to the ceiling space. Alternatively, wall cavities can be vented externally.

10.10 Ventilation Pathways

Because of the cooking, washing, and respiration of the inhabitants, the humidity in the ceiling cavity is most often greater than that of the surrounding atmosphere. The space may also be colder than the ambient air at night due to [10.12.3 Night Sky Radiation](#)

Warm air naturally rises but has little tendency to move laterally, except when a strong wind blows into roof vents or causes substantial differences in air pressure on opposite sides of the building. That is why eave-to-ridge ventilation is more effective under typical conditions than side-to-side ventilation.

Ventilation of a cavity space is desired to reduce the accumulation of condensation and assist in removing excess heat. Natural ventilation via the ribs of metal roof and wall cladding can achieve this adequately in normal circumstances, but additional provisions are often necessary. In all cases, air must flow naturally through the profile crests without barriers such as profiled foam filler strips at the eaves and apex, or impingement of bulk insulation.

Many roofs not overtly displaying the signs of excessive moisture build-up would benefit from an increase in ventilation.

Simple techniques to provide a clear path for air to enter, travel along and exit the roof cavity can include:

- Eaves:
 - Allow air entry by soffit vents, over-fascia or behind-fascia vents, or by using fleece-lined roofing material.
 - Ensuring that insulation does not impinge on the underside of the roof at the eaves. This can be achieved by using a heeled truss or eaves baffle, or both.
- Body:
 - Ensuring that the air can travel under the roof. If insulation is flush with the underside of the purlins it can be done using a vented batten between the purlin and the underlay, or by using fleece lined roofing material.
- Apex:
 - Making the roof underlay discontinuous at the apex by cutting or slitting the underlay and using a vented soft edge or vented ridge.

Sarked roofs must have a gap in the sarking at eaves and apex, or by an alternative eaves-to-apex passage.

With skillion roof or flat roof construction, the air volume is significantly reduced, so moisture saturation levels are more quickly reached. Also with these roof types, air flow paths are more easily obstructed. In skillion roofs with tongue and groove ceilings, a layer of roof underlay immediately above the ceiling will provide a vapour check and air barrier to compensate for the porosity of the ceiling. For more advice on skillion roof ventilation, see <https://www.branz.co.nz/pubs/branz-facts/roof-ventilation/4-skillion-roofs/>

Roofs continuous over an apex, such as barrel curved roofs or roofs with prickled ridges, must have adequate ventilation to prevent the accumulation of moisture at the apex.

Long low pitched roofs will benefit from increased ventilation which may also assist in minimising thermally induced expansion noise. Ventilation typically increases as the roof pitch increases. Air movement through the crests depends on the spacing and area of the crests, roof pitch, and overall length of the sheeting. Corrugate and

trapezoidal roofing provide more ventilation than secret-fix roofing. Ventilation through the crests still depends on air being allowed to enter at the eaves and escape at the apex.

Through or tray section roofs have smaller ventilation channels and may require additional ventilation.

The use of profiled closures at eaves or ridge will create a substantial air barrier and alternative ventilation paths must be created.

Additional roof space ventilation may take the form of:

- louvre vents in gable-ends,
- soffit vents,
- proprietary ridge vents,
- ventilated soft edge strips on transverse flashings, or
- mechanical or wind-powered vents positioned close to the apex.

Where eave-vent intakes and ridge-vent exits are both employed, the area of the ridge vents should be less than that of the eave vents. More air escaping at the ridge than entering at the eaves can lower the pressure of the attic cavity and encourage more ingress of moist air from the dwelling area.

In pitches of 30° or less cross venting from eaves to eaves alone is generally enough when combined with natural passive ventilation at the apex.

A common rule of thumb is to have a total ventilation cross-section area equal to 1/300 of the ceiling area. In NZ buildings, much smaller ratios have proven sufficient in most cases.

Increasing roof space ventilation above the insulation has only a small effect on R values. Ventilation of spaces above bulk insulation is not only desirable but prevents insulation losing effectiveness due to absorbing moisture.

Partial filling of a ceiling cavity with bulk insulation in flat roofs can severely reduce the amount of free air available to absorb incoming water vapour, thereby increasing saturation levels. Adding insulation while re-roofing must be done with due consideration; unless the amount of ventilation of the cavity is increased or a vapour check layer is used below the insulation, internal moisture problems can occur.

10.10.1 Methods of Ventilation

The primary purpose of ventilation is to replace the moist air in the ceiling cavity with drier air from outdoors.

As warm, wet air tends to rise, a vent placed in the soffit or at the lower end of a roof will normally operate as an intake vent and a vent at the apex as an exhaust vent, but wind direction can reverse this relationship. Gable-end vents or vents aligned horizontally will act as an intake or exhaust depending on the wind direction.

10.10.1.1 Soffit Vents

Soffit vents can be made in a range of styles to suit the application. As wind pressure differentials are highest at the eaves, they are an efficient ventilation solution and they are also very weather resistant. Soffit vents should always be installed to allow free movement of air into the cavity and should not be blocked on the interior side by insulation or other material.

10.10.1.1A Mono-Pitch Sarked Roof to Parapet with Vented Battens

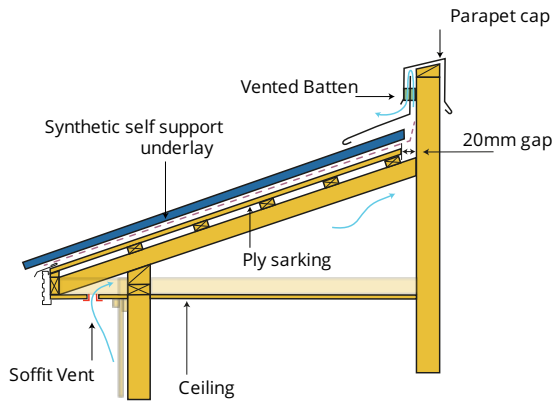

In some applications, vented battens may be needed to increase airflow

10.10.1.2 Fascia Vents

Vents above fascia may require re-positioning of the fascia to allow for their depth. Fascia vents should be used in conjunction with a high fronted spouting so that the ends of the sheet and the vent are not exposed to driven rain.

10.10.1.3 Ridge Vents

Ridge vents, such as continuous or intermittent ridge vents or vented head apron flashings, should always be used in conjunction with intake vents at a lower level.

Saturated water vapour can enter the building when commercial ridge vents are subjected to negative pressures or at times of high humidity associated with mist or fog. Such water vapour can form condensation on the structural framework and appear as a leak. Ridge vents without adequate intake vents can also lead to leakage.

10.10.1.3A Sarked Roof to Ridge Vent

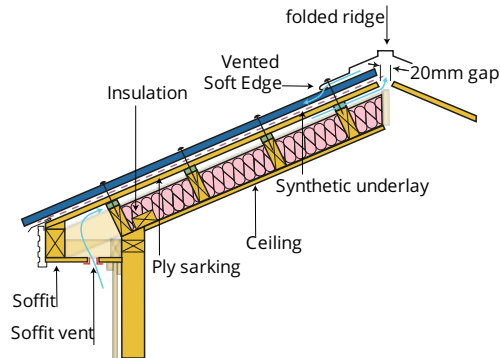

10.10.1.4 Vented Soft Edge

Typical soft edge is either soft aluminium or perforated aluminium with PIB rubber backer. The latter is more common. The PIB rubber, when dressed down on a hot day, can adhere to the roofing surface and prevent the escape of air at the apex. By removing all or most of the PIB backing this is avoided, and the perforations in the aluminium become an effective pathway for trickle ventilation, while still being an effective baffle against wind-blown moisture. This product is marketed as vented soft edge and is available from all suppliers.

10.10.1.4A Vented Soft Edge on Corrugate



10.10.1.4B Vented Soft Edge with PIB Backer



10.10.1.5 Turbine Vents

Wind-driven turbine vents rely on wind to rotate the fan blades. This creates a low-pressure area, so they draw air from the ventilated area at a greater rate than stationary vents. The amount of air movement can be dampened but is normally uncontrolled; it is developed as a function of wind speed as well as turbine size and efficiency. Turbine vents, unlike commercial ridge vents, are unaffected by wind direction and they are less prone to leaking.

10.10.2 Battens

Battens may be required to provide create a separation space between roofing and underlay. In some applications, they may need to be ventilated to achieve sufficient airflow.

The type and number of fixings required to fix the counter battens to the roof structure must meet the design wind load, or the roof fasteners should be long enough to achieve the required penetration into the purlin below.

Battens or counter battens, if not fixed by extended cladding fasteners, can be fixed using countersunk purlin screws or if fixed with hex headed screws, they should be counter-bored before installation to avoid damage to the roof cladding.

Steel top hat, C or Z sections are also used as counter battens but require an additional insulating spacer to avoid thermal bridging.

10.10.2A Using Z Counter Battens with Insulating Spacers

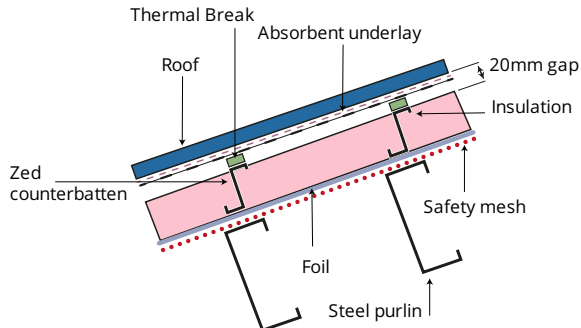

10.10.3 Applied Fleeces

Roof sheeting is now available with a synthetic fleece applied directly to the underside of the profile. This works in the same manner as roofing underlay, absorbing condensation into the fleece and releasing it into the atmosphere when ambient conditions improve.

The fleece follows the contours of the profile. By removing the separate layer of underlay, every crest becomes a pathway for ventilation. On a gable roof, this will approximately double the air changes in a roof over conventional construction, without the height disruption, cost, or inconvenience of a ventilated batten.

Another advantage of these products is that they greatly increase speed of lay of a roof, and avoid delays due to excessive wind. They are available on all corrugate and trapezoidal profiles.

10.11 Underlay

Condensation that forms on the cold under-surface of the roof system must be contained until ambient conditions allow it to evaporate. Containment is normally achieved by using an absorbent roofing underlay. It is the role of roofing underlay to absorb moisture temporarily and then release it back into the atmosphere.

A common misconception holds that the roofing underlay acts as a drainage plane, channelling condensation from underside of the metal roof to the gutter. In practice, most of the condensation forms on the underside of the underlay. Although roofing underlays are permeable, they still form a substantial vapour check; and as they are in contact with the roof, they are at a similar temperature. Any condensation that does form on the underside of the roof and falls onto the underlay generally only tracks down the underlay as far as the next purlin, where it is trapped and is absorbed by the underlay. Underlay is also affected by holes from roofing fasteners so is unreliable as a "second roof".

As it is designed to execute its primary purpose of aiding in the management of internal moisture, underlay should not be used as a compensation for unreliable weatherproofing design and installation

10.11A Roof Cavity Condensation

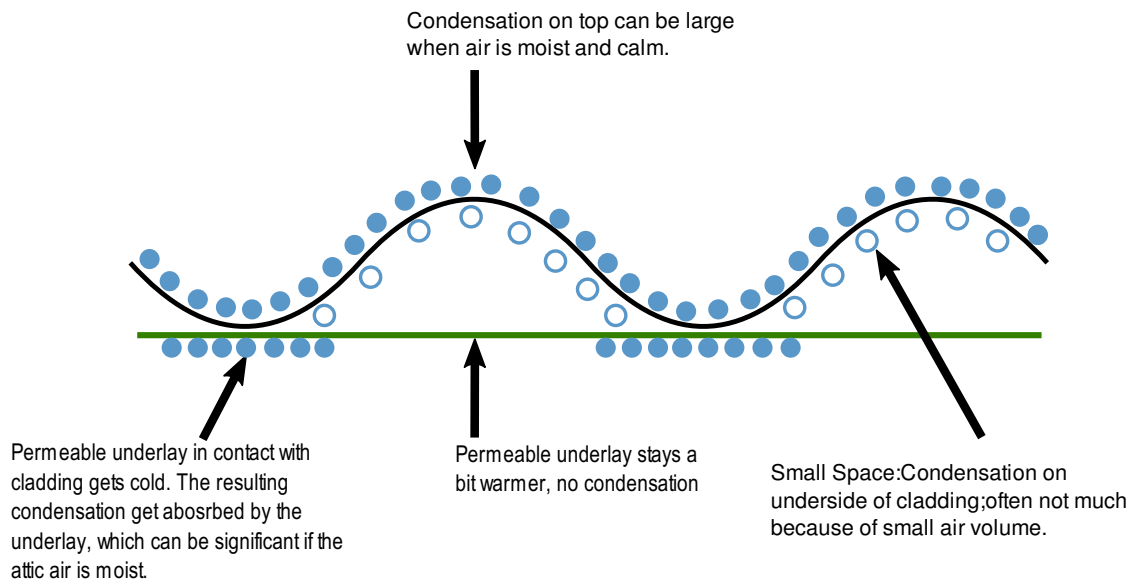

10.11B Condensation Under Roofing Underlay



Most condensation on the underside of the roof system occurs under the roofing underlay.

The presence of pooling condensate on the upper side of a roofing underlay indicates that the absorptive capacity of the underlay has been exceeded. Not only the underlay will be saturated, but also the ceiling structural members and insulation; mould, corrosion, and decay are inevitable. The cure is to decrease the amount of moisture entering the ceiling cavity or increase ventilation of the ceiling space.

10.11C Chronic Condensation



Chronic condensation problem caused by induction of moist air into the ceiling cavity. Although the underlay here is doing a good job of containing the surface water, the timber trusses, insulation, and ceiling below the underlay were saturated with water.

Underlay also acts as a partial air barrier. (Rigid air barriers are also available.) Water will generally only go where gravity or air pressure takes it. By effectively reducing the space behind cladding, the underlay allows rapid pressure equalisation on each side of the cladding, thereby reducing the ability of water to enter the space.

10.11.1 Underlay Requirements

The NZBC requires underlays under profiled metal roofing and direct-fixed metal wall cladding on lined residential

buildings to be both permeable and absorbent.

Underlays fixed to the dry side of a lined drained cavity may be permeable and non-absorbent.

Underlays are not required in unlined structures, but in such cases non-permeable, non-absorbent underlays such as foil are typically used to increase reflectivity and to minimise condensation.

In some wall and roof applications, the underlay is required to be Fire Retardant with Flammability Index ≤ 5 when tested to AS1530.2. Refer NZBC C/AS3-AS6, clause 4.17.8

Underlays designated as self-supporting can be laid without support at spans up to 1.2 m.

Other requirements for underlays vary for different cladding systems, but the important features of absorbency, permeability, water resistance, tensile strength, edge tear resistance, PH, and durability are important to comply with the requirements of the NZBC.

The Code of Practice recommends synthetic self-supporting fire-retardant underlays for residential roofing applications.

10.11.2 Types Of Underlay

Apart from their fire retardance and ability to self-support, underlays are classified according to their absorbency and permeability.

Permeable and Absorbent:

- Kraft paper-based – bitumen impregnated paper
- Synthetic – 2 or 3 layers, using permeable synthetic film strengthened by sandwiched non-woven fabric.

Permeable, non-absorbent:

- Synthetic permeable non-absorbent underlays are mainly used as wall wrap inside a drained cavity or with direct fixed absorbent claddings.

Non-Permeable, non-absorbent:

- foil – Reflective aluminium foil over a flexible substrate. These can be either double-sided or white-faced.

10.11.3 Underlay Usage

In lined buildings and dwellings, an absorbent permeable underlay is required under metal roofs. The same applies to direct-fixed steel wall cladding, but underlays used behind a drained cavity are not required to be absorbent.

For aesthetic reasons, a foil-faced (or white-faced) vapour check layer may be used in unlined commercial or industrial applications to reduce heat radiation from the roof cladding and provide enhancement of light. For insulated applications, foil is normally used as a vapour check under the insulation and an absorbent permeable underlay used above with a 20 mm gap from the roof cladding.

On non-residential dwellings, profiled roof-light sheeting running in continuous lengths from the ridge can have multiple skins to avoid condensation dripping from the sheeting or plastic sheet with a spacer can be used to lessen condensation. Roof underlays should not be laid continuously under translucent roof or wall cladding.

10.11.4 Underlay Durability

NZBC Clause B2.3.1 requires building elements that are non-structural and are moderately difficult to replace to have a durability of 15 years. It also requires building elements that are part of a building system and are difficult to replace to have the same durability or to be designed so materials with lesser durability can be replaced without removal of more durable elements.

Compliance with NZBC B2, therefore, requires roofing underlay to have durability equal to that of the roof cladding and no less than 15 years.

For durability reasons, the roof underlay should ideally finish on to an eaves flashing, so that the underlay is not exposed to UV in the long run or be able to flap or vibrate in the wind.

10.11.5 Installing Underlay

Underlay can be laid vertically or horizontally. Side laps must be a minimum of 150 for roofs and 75 mm for walls; end laps must be a minimum of 150 mm for both roof and wall cladding. At the eaves, the underlay should terminate on the upper side of the eaves flashing or overhang fascia by no more than 20 mm.

The COP recommends that all underlay is terminated at the ridge, and if not it should be slit or slotted to allow passive ventilation of the ceiling cavity.

The COP allows roof and wall underlay to be laid either vertically or horizontally in all cases. However, that is in divergence with E2/AS1, so it is advised for buildings within the scope of E2/AS1 (ie, buildings designed within the scope of NZS 3604) that the requirements of the local TA is sought before diverging from E2/AS1.

Rips smaller than 75 mm on walls or roofs can be repaired using a compatible flashing tape, but roof underlay damage greater than this requires a new piece of underlay captured by the cladding fastenings.

Flue penetrations must have a minimum distance of 50 mm from the outer liner to any underlay or flammable material.

E2/AS1 requires self-support underlay laid horizontally on support to be used at pitches below 10°. That is not a requirement of the COP as underlay support is no substitute for good ventilation design and effective weathertight details.

When using vented battens, the underlay should be positioned on the upper side of the batten, directly under the roof cladding. Having the underlay directly under the roof allows the battens to vent the roof cavity directly and allows the underlay to perform its normal design function; putting roofing underlay under ventilated battens impedes roof cavity ventilation

With re-roofs in any material, it is not acceptable to lay a new roof over existing underlay or underlay support, unless the latter is in "as new" condition. See [14.20 Fixing Aluminium Sheeting](#).

Wall underlays must have a minimum side lap of 150 mm, and an end lap of 75 mm. Wall underlay on a drained cavity should be on the dry (inside) face of the cavity, and be rigid enough to restrain wall insulation from contacting the cladding, or have secondary strapping to achieve such.

10.11.5.1 Horizontal Laying

Horizontally laid underlay must be supported if used under long-run metal roofing, unless both edges are supported by purlins. Under metal tiles, self-supporting underlay can be laid over the roof trusses at spans up to 1.2 m.

Underlay laid horizontally must be laid starting at the lowest point of the roof, running over the bottom purlin and must overlap into the gutter by a maximum of 20 mm to prevent wicking. When an eaves flashing is used the underlay should terminate on the downslope of the flashing.

To lay roof underlay horizontally, more than one roll can be progressively unrolled, one roofing sheet width at a time. Running multiple rolls straight can, however, be difficult in windy conditions.

10.11.5.2 Vertical Laying

The laps on vertically laid roof underlay may face in either direction, as the direction of lay is usually dictated by construction sequencing or wind direction at the time of laying.

The bottom end of vertically laid roof underlay must overlap into the gutter by a maximum of 20 mm to prevent wicking. When an eaves flashing is used the underlay should terminate on the downslope of the flashing.

10.11.5.3 Underlay Support

Self-supporting underlays in lined roof spaces may be laid unsupported at spans up to 1.2 m. Other underlays must be supported. Underlay support may be safety mesh, hexagonal galvanised wire netting, builders' tape, or other suitably strong and durable material.

Safety mesh must be designed and installed to comply with the requirements of the AS/NZS 4389:2015

Corroded galvanised safety mesh and wire netting can be damaging to any metal roofing and especially to pre-painted aluminium. Pre-painted aluminium cladding must be protected from contact with potentially corroding steel including netting, staples, or fasteners, See [14.20 Fixing Aluminium Sheeting](#)

10.12 Additional Information

10.12.1 Cold Roofs

With cold roof construction, the under-surface temperature of the metal roofing will at times be quite low, so the primary tool of managing condensation is controlling the concentration of water vapour in the attic space. Some condensation is inevitable, and it must be managed to ensure the wetness is not excessive in either degree or duration – allowing moisture to accumulate.

In typical cold roof construction, the insulation is at ceiling level and there is an air gap between the insulation and the roof surface.

10.12.2 Warm Roofs

With Warm Roofs, the insulation is in direct continuous contact with the underside of the roof. The most common form of Warm Roof in New Zealand is pre-formed insulation panel. Other proprietary systems may consist of several layers with a vapour control layer on the underside.

Warm roofs do not inherently have the same natural ventilation as a cold roof, so the internal environment may require management to prevent condensation problems.

10.12.3 Night Sky Radiation

Roof cladding absorbs radiation from the sun and the attic space becomes warmer; some of this heat is radiated into a clear sky at night.

Because all objects radiate heat to cooler objects, night sky radiation will occur when there are no clouds in the sky. The radiation rate depends on the emittance of the roof cladding.

Radiation to the sky can cause the cladding temperature to drop as much as 5°C below that of the surrounding air; that causes dew when the surface temperature reaches dew point or frost if the temperature falls below zero.

10.12.4 The Mechanics of Condensation

Water exists in 3 states: solid (ice), liquid (water), and gas (water vapour).

10.12.4A Hydrogen Bonding

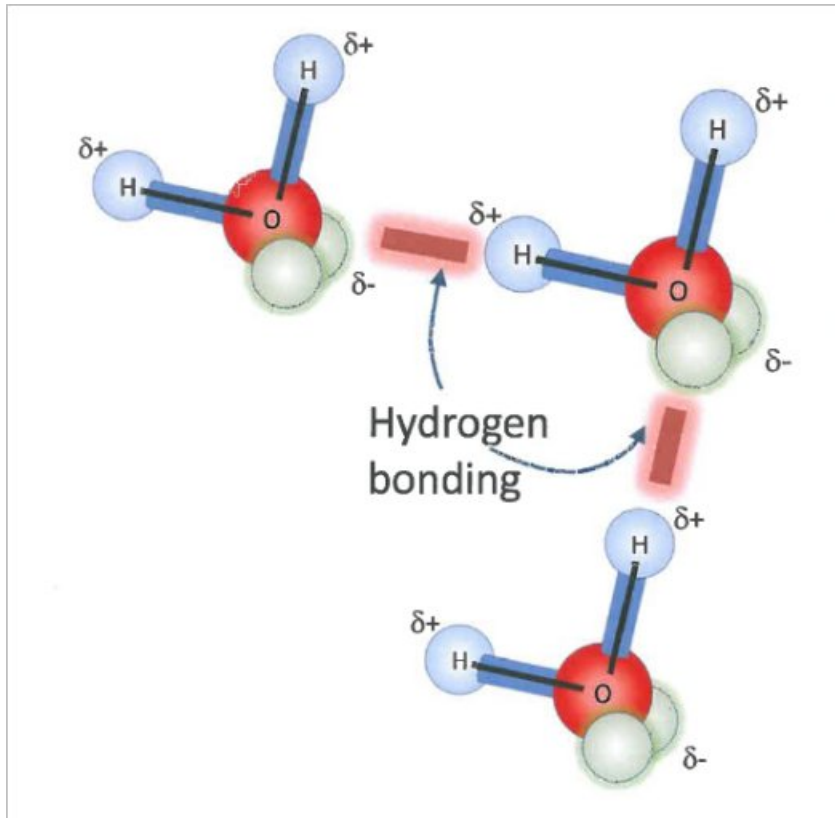

Water molecules in liquid form bonds which create a dense material.

In ice and liquid water, individual H₂O molecules bond together in a special way, called 'hydrogen bonding'.

In gas form, the kinetic energy of the molecules has overcome these hydrogen bonds, and so the individual water molecules are free to move. The water molecule itself is light compared with other gases in the atmosphere, so it tends to migrate upwards, ie, into the roof space.

Water vapour may condense into liquid form when the concentration rises or the temperature drops. The temperature at which air can hold no more water is called the 'Dew Point'. The water vapour capacity of air is relative to temperature.

10.12.4B Shower Condensation



The high humidity created while showering causes condensation on even relatively warm surfaces because of the high concentration of vapour.

10.12.4C Condensation on a Cold Surface

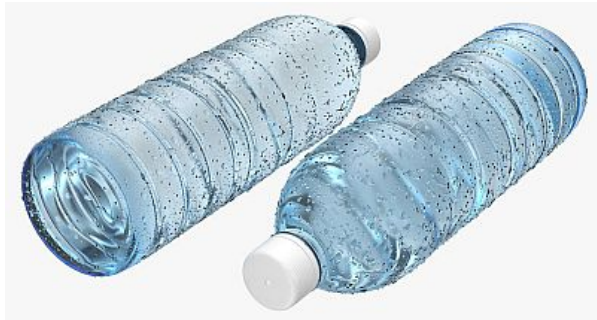

In warm conditions, condensation will form on a cold surface, even when the concentration of water vapour in the atmosphere is low.

10.12.5 Underlay Standards

Permeable underlays must comply with NZS 2295, Amendment 1:2017, as shown in Properties of Roofing Underlay, or have an appropriate Product certification such as a Codemark certificate.

Reflective foil underlays must comply with AS/NZS 4200.1:2017

10.12.5A Minimum Requirements for Underlays for Metal Roof Cladding

Classification	R1	R3	R2	R4
Grade	Heavyweight		Self support	Self-support
Type	Kraft	Synthetic	Kraft	Synthetic
Application	Residential or light commercial buildings			
Property	Unit			
Absorbency	g/m ²	≥ 150	≥ 150	≥ 150
Water Vapour Resistance	MN s/g	≤ 7	≤ 7	≤ 0.5
Water resistance	mm head	≥ 100	≥ 100	≥ 100
Tensile Strength MD	KN/m	≥ 9	≥ 3	≥ 11
Tensile Strength CD	KN/m	≥ 4.5	≥ 2	≥ 6
Edge Tear Resistance MD	N	≥ 40	≥ 100	≥ 70
Edge Tear Resistance CD	N	≥ 35	≥ 80	≥ 55

Based on Table B1 of NZS 2295 Amendment 1:2017.

- Self-supporting (S/S) is defined as strong enough to support its own weight up to a 1200 mm span.
- pH between 5.5 and 8.0.
- Kraft based underlays shall have shrinkage less than 0.5% and maximum run-length of 10 m.
- Synthetic underlays may have any run length.
- Any underlay is regarded as fire-retardant if it has a Flammability Index (FI) of 5 or less when tested to AS/NZS 1530 Part 2.

10.12.6 Relative Humidity

RH is strongly dependent on temperature. For instance, a parcel of air at 15°C and 50% RH is cooled down to 10°C. Now, the relative humidity of this parcel of air will be close to 70%, without the actual amount of water having increased. Relative Humidity expresses how close the air is to being saturated with water vapour. Warm air can hold more moisture in absolute terms, cold air less. If the air becomes saturated (RH 100%) water vapour will condense as mist in the air or as water on adjacent cold surfaces.

Relative humidity is a suitable measure when the risk of condensation on surfaces or mould growth is to be evaluated.

10.12.7 Absolute Humidity

Absolute Humidity is measured in grams of water per volume of air (grams per cubic metre [g/m³]). It is not temperature dependent and in the example above the absolute humidity would remain unchanged at around 6.4 g/m³, regardless of the temperature change.

Absolute humidity is a suitable measure if one is looking for sources or sinks of water in an environment where temperature is changing. If the absolute humidity is cycling during the day, eg, increases in a roof cavity as the temperature rises during the day. It could indicate that moisture is released by the building materials during the day and absorbed or condenses during the cooler nights.

10.12.8

Water Vapour Pressure

Water Vapour Pressure is more based on the fundamental physics and expresses the contribution (ie, the partial pressure) of water vapour to the total pressure of an air mix. For example, at a pressure of 1000 Pa (1kPa), the partial pressure of nitrogen may be 700 Pa, the partial pressure of Oxygen 200 Pa and the partial pressure of water vapour 99 Pa, and other gasses 1 Pa.

This parameter is useful to evaluate moisture migration from one point in the building to another.

11

Natural Light

Natural Lighting covers the use of translucent roofing material for providing interior illumination. These typically take the form of profiled sheeting, stand-alone units, or flat sheet systems.

Skylights profiled to match the roof sheeting may be made from glass reinforced polyester or polycarbonate. Proprietary stand-alone skylights may have polycarbonate, glass, or acrylic panels. Single or multi-skinned sheet products can be used in conjunction with proprietary support systems to replace glass in conservatory type situations.

Main headings include:

- Compliance
- Profiled roof lighting
- Stand-alone roof lighting
- Sheet systems

11.1 Clause G7 NZBC

Objective

NZBC G7 aims to safeguard people for illness or loss of amenity due to isolation from natural light and the outside environment.

Functional Requirements

Habitable spaces shall provide adequate openings for natural light and visual awareness of the outside environment.

Performance

Natural light shall provide an illuminance of no less than 30 lux at floor level 75% of the standard year.

Openings to give awareness of the outside shall be provided in suitable locations.

11.1.1 Compliance

The NZ Building Code G7.2 requires adequate natural light and an awareness of the outside environment for housing, old people's homes, and early childhood centres. In other buildings, natural light is often used to create ambience and reduce the need for artificial lighting.

All plastic sheets used with profiled metal cladding in New Zealand must comply with the structural, durability, and external moisture requirements of the New Zealand Building Code.

All plastic sheeting should comply with the AS/NZS 4256 and AS 1562.3 and should be tested in accordance with the AS/NZS 4257.

11.2 Natural Light Materials

The most common form of natural roof lighting used in commercial and industrial buildings comprises single skin, glass-reinforced plastic (GRP) sheets matching the profile of the metal roofing, running from ridge to eaves in continuous lengths of up to 12 m, sometimes longer. For other applications such as housing, polycarbonate sheeting is more commonly used. Polycarbonate is available in stock sheet lengths of up to 7.2 metres.

Profiled PVC roof lights are now rare as they suffer from embrittlement when exposed to UV.

GRP combines polyester resin and chopped glass fibre. AS/NZS 4256.3 requires sheets to contain a minimum of 22% glass fibre by mass and to be marked with their classification and weight.

11.2A Comparison of GRP and Polycarbonate.

GRP	Polycarbonate
Available in all profiles	Available in limited profiles
Available in long run	Available in standard lengths
Available in different thicknesses	Available in one thickness
Durability >25 years	Durability >25 years
Will lose transparency with age	Will maintain initial transparency
Gives diffuse light	Gives direct light
Thermal expansion 2 x that of steel	Thermal expansion 5x that of steel
Available in tinted or opaque	Available tinted
Reasonable light transparency	Excellent light transparency

Polycarbonate is more popular for shorter runs and continuous widths, where clarity and stable appearance are considered an aesthetic attribute.

Stand-alone and flat-sheet roof lights may be manufactured from translucent or transparent polycarbonate, acrylic, or glass sheeting.

11.2.1 Glass Reinforced Plastic (GRP)

Glass Reinforced Plastic (GRP) combines polyester resin and chopped glass fibre. AS/NZS 4256.3 requires sheets to contain a minimum of 22% glass fibre by mass and to be marked with their classification and weight.

GRP is suitable for in-service temperatures of -10° to 70°C and some GRP sheets are available in a fire resistant grade.

GRP should have a minimum thickness of 1.1 mm, but it is available up to 3 mm thick.

11.2.1A GRP Weight in g/m²

mm	=	g/m ²
1.1		1800
1.2		2000
1.3		2100
1.5		2400
1.9		3000
2.1		3300
2.5		4000
3.0		4880

The exterior surface of GRP is covered with either a polyester film or a layer of gel-coat cast as the sheet surface. Sheets can have a film or a coating on one or both sides or have a film on one side and a coating on the other. The performance of GRP is related to both light transmission and durability of the various films, and coatings can provide different performance for each category in different environments.

N.B. Performance in both of these areas is not necessarily directly related.

The roofing contractor must ensure that the correct weathering surface of plastic sheeting is placed uppermost as the durability and warranty depend on placing the sheet the correct side up.

11.2.2 Polycarbonate

Polycarbonate is a tough, clear thermoplastic polymer with a higher deformation temperature than PVC.

Polycarbonate is manufactured with a co-extruded UV resistant top layer, which will resist weathering, but its durability depends on the thickness of the top layer.

Profiled polycarbonate sheeting has a limited spanning capacity and requires greater provision for expansion than GRP. It is available in thicknesses from 0.8 mm to 1.5 mm but is only available in a limited range of profiles.

Flat multi-wall extruded sheets with one or more air gaps have a thinner wall thickness but derive their rigidity from the shape of the profile. They are limited in spanning capability, but come in wide sheets, fixed into proprietary extrusions, and are suitable as continuous barrel vaults and as double skin roof lights.

Surface coatings provide different levels of durability, chemical resistance and weather resistance.

Polycarbonate sheets must not be fitted above sprinklers as they can drop out in a fire and interfere with the sprinkler's function.

11.2.3 PVC

PVC is a compound of polyvinyl chloride manufactured with stabilisers but without plasticisers that complies with AS/NZS 4256.2. Profiled PVC roof lights have a limited spanning capacity and need greater provision for expansion than other plastics or metals.

Profiled PVC sheeting ranges from 0.8 mm to 1.5 mm in thickness but is only available in a limited range of profiles. PVC softens at 80°C and will act as a smoke vent when heated during a fire. It has a service temperature of 60°C and a tensile strength of 52 MPa at 20°C.

PVC may not satisfy the 15-year durability requirements of the NZBC; it is not regarded as suitable for commercial or industrial use and should not be used in habitable buildings.

PVC sheets must not be fitted above sprinklers, as they can drop out during a fire and interfere with the sprinkler's function.

11.3 Performance – Structure

GRP Sheeting is measured in weight per square metre. The test provisions of AS/NZS 4257 require the measure to be calculated from the area of the profile, including the overlap. Because the mass of plastic sheeting varies between profiles, the thickness will vary for different profiles of a given weight per square metre. Deeper profiled products are usually supplied as standard at a greater weight per square metre than more material-efficient profiles.

11.3.1 Point Load on Translucent Sheets

Standard profiled roof lights are classified as brittle roofing and are not suitable for roof traffic. They are normally laid over safety mesh to AS 4859. (See [13.4.4 Safety Netting](#))

Trafficable roof lights are normally rendered trafficable by embedding a woven glass mat into the material. They must be tested under the point load test provisions of AS 4040.1, AS/NZS 4040.4, and AS/NZS 1562.3: 2006. Plastic roof lights.

Non-trafficable sheets over one sheet in width should be provided with a walkway, terminate short of ridge and/or eaves, to enable transverse traffic.

11.3.2 Distributed Loads on Translucent Sheeting

The spanning capacity of profiled roof lights depends on the profile shape, material thickness and composition, the number of fasteners per square metre, and the washer type and size.

Pull-through of the fastener is the most common failure mode of profiled translucent sheeting, so it should always be installed with a load spreading washer unless otherwise specified by the manufacturer.

Additional support can be obtained from adjacent metal cladding by using mid-span supports, alternatively, the thickness of the roof lights may be increased.

Profiled translucent sheeting must be designed to be capable of withstanding design wind loads, using the manufacturer's literature.

11.3.2A Translucent Sheet with Midspan Support

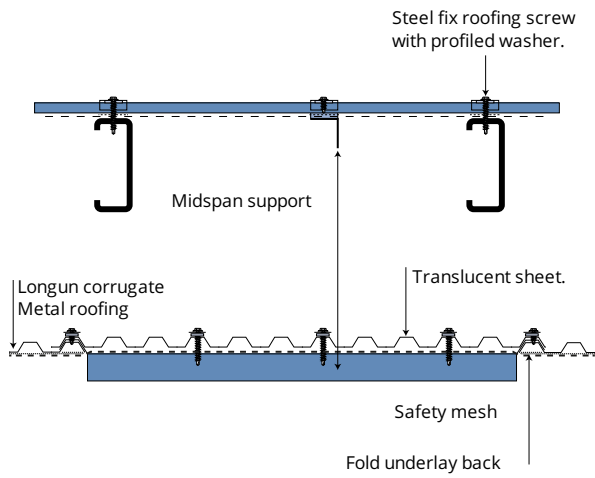

11.4 Thermal Resistance

Roof lights can increase both the heat entering and leaving a building.

Tinted sheeting can be used to decrease heat build-up through radiation. Tinting can be coloured or translucent.

To decrease heat loss and prevent condensation, multi-skinned systems can be employed to provide insulation. In colder areas, UV-stabilised EVA copolymer film is often used under profiled skylights to minimise condensation. Where buildings are heated, or where condensation cannot be tolerated, multi skinned systems are recommended.

11.4A Double-Skinned Rooflight.

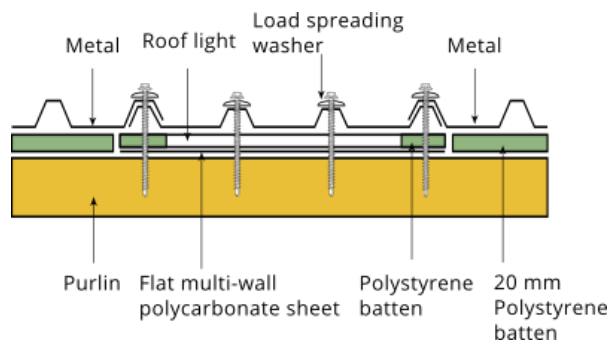

11.4B Rooflight without Spacers

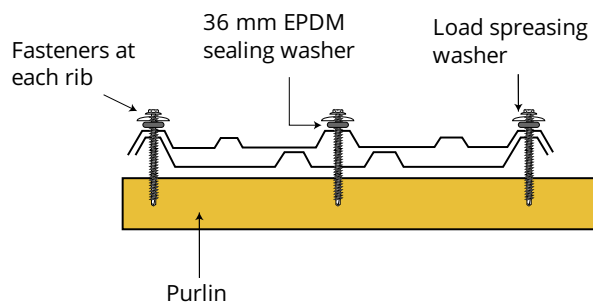

11.4C Rooflight with Spacers

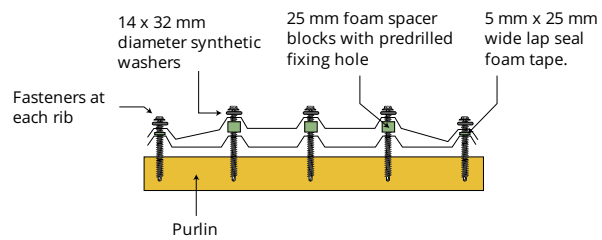

11.5 Light Transmission

The amount of roof lighting required in a building depends on the building design or use, the external light conditions of the location, and the reflectance of internal surfaces. Regular roof light areas range from 5% of the floor area for warehouses to 10 – 15% for industrial buildings, and 20% for sports halls and factories where intricate work is done.

Proprietary skylights are usually strategically positioned to bring borrowed light into specific areas that are not otherwise naturally lit. Often these are also designed to provide ventilation.

11.6 Installing Translucent Sheets

To provide for thermal expansion, all profiled roof lighting must be fitted with fasteners installed through an oversize hole and with a load spreading washer. Some fasteners drill their own clearance holes, otherwise pre-drilling is required. Although GRP has approximately twice the expansion as steel, it absorbs less energy from the sun, so the same expansion allowances as used for the adjacent steel sheet can be applied.

Roof netting and safety mesh can damage GRP through expansion movement and walking traffic. GRP can be protected at the purlin by placing a small slip sheet of GRP between the netting and the roof light.

11.6A Translucent Sheet End Lap

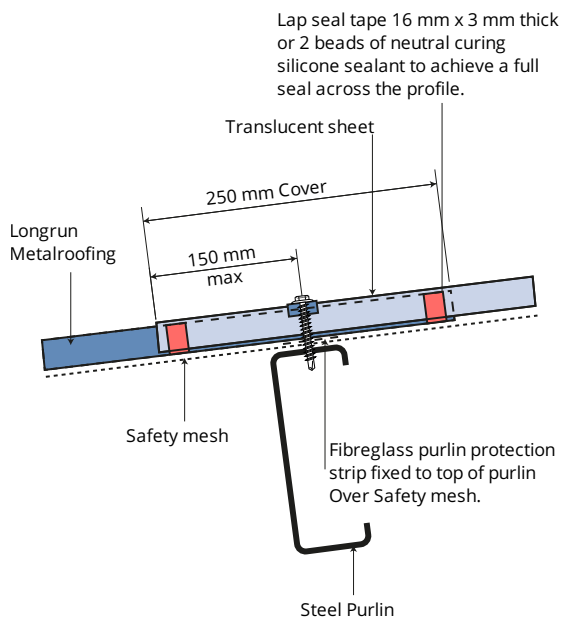

Polycarbonate sheets expand more than steel, and so are only available in lengths up to 7.2 m. When directly installing polycarbonate sheets, friction tape can be placed on the purlins to reduce thermally induced noise.

Manufacturers recommend side lap fasteners on translucent sheets to maintain the integrity of the side laps.

Turn up stop ends are not easily formed with profiled skylights. To prevent blow over at the upper end of sheets, an angle or odd leg J-shaped channel is normally attached to the upper end of sheets with rivets and sealed with silicon or MS sealant.

11.6B Translucent Sheet Stop End

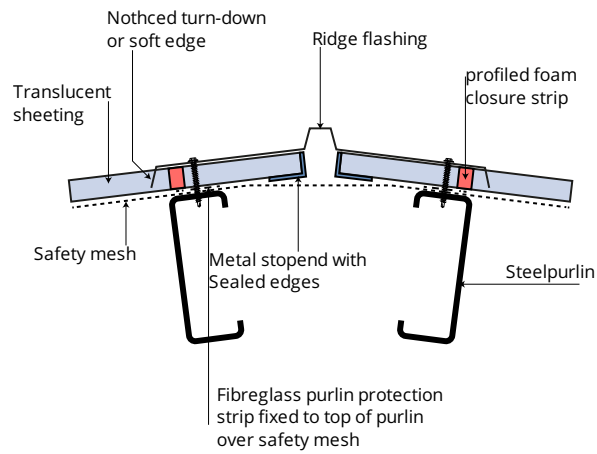

11.7 Stand-Alone Rooflights

Stand-alone roof lights are available in many configurations with the most common being a glass-faced rectangular or square design, or a dome. Both are available either clear or tinted and may be integrated with a permanent, manually operated, or automated ventilation function.

Rectangular skylights typically consist of a timber or aluminium base which must be flashed into the roof cladding, using one of the methods detailed in [9 External Moisture Penetrations](#). The designer should select which flashing detail is optimal for the application and detail it accordingly. To enable efficient design and prevent excessive use of over flashings, designers should also consider the placement of skylights in relation to each other and other architectural elements,

Retrofitted skylights, not included in the original design, often result in unsightly, leaky, and excessive over-flashings. Such additions often evade compliance inspections. If skylights are likely to be required, it is strongly recommended that thought be given to their location and design so that they can be appropriately detailed on the consent drawings.

Dome flashings often come with a flashing kit, making them simpler to install, and many have flexible light tubes leading to a ceiling light diffuser, avoiding the need to frame out and line the roof space between the skylight and the ceiling. This allows the upper section to be positioned in an optimal position to facilitate flashing design.

11.7A Skytube

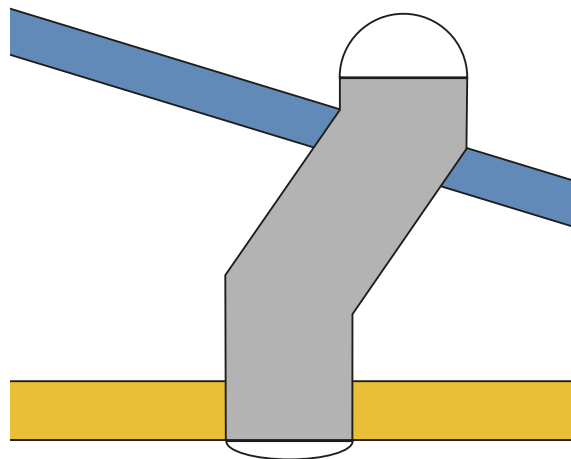

11.7B Skylight

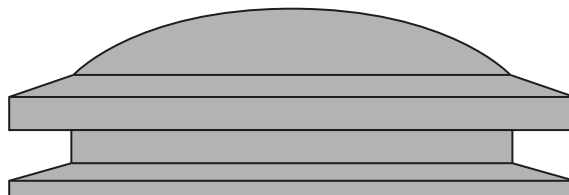

11.8 Flatsheet Rooflights

Flat sheets of translucent material can also be used side by side to form a continuous roof light, wall lighting, or conservatory. Materials may be single or multi skinned glass, polycarbonate or acrylic.

These are almost exclusively proprietary systems so design advice should be sought from the distributor/manufacturer.

12

Fitness For Purpose

In addition to Corrosion (NZBC: B2 – Durability), other issues which may affect the lifespan or perceived quality of metal roof and wall cladding, include:

- Oil Canning.
- Purlin Creasing.
- Colour Differential.

12.1 Roof Noise

Roof noise refers to excessive intermittent sound emanating from the area of a roof surface or ceiling cavity.

Sound is usually created by movement and is carried by vibratory movement of the air. The movement that generates sound can be triggered by three main factors:

- Wind.
- Precipitation (rain, hail, or snow).
- Temperature (thermal).

Each of these can be broken down into sub-groups.

12.1.1 Wind Noise

Roof noise triggered by the wind can take several forms:

- Underlay flutter,
- Banging of the roof itself, or things against the roof,
- Vibration of flashings.

12.1.1A Underlay Flutter

Underlay flutter will be perceived as a high-pitched noise. Depending on its origin, it can be minimised using various techniques, for example:

- If it is coming from the eaves, cutting the underlay back from the spouting and installing an eaves flashing.
- If it is coming from the body of the roof, installing a high front gutter.
- Installing spray-on foam insulation.

12.1.1B Wind Banging

Wind banging can be the pan drumming or banging against the sarking or purlin support. It normally only occurs with standing seam profiles and it is a function of the roof design, material thickness, and wind loads. These problems should be referred to the manufacturer or designer.

12.1.1C Flashing Vibration

Excessive movement or insufficient clearance between a penetration and the cladding may also cause noise.

Flashing vibration can be a whistling noise or a high-pitched sound like an engine, known as motor boating. The edges of all flashings should have a stiffening fold and the vertical face should be fixed to the structure or wall cladding to avoid vibration.

12.1.2 Precipitation Noise

Most people find the sound of rain on the roof comforting, however, it may be intrusive.

The best way to attenuate precipitation noise is to increase the insulation levels in the ceiling space

Chip-coated metal tiles are likely to produce less precipitation noise than roll formed cladding. Fleece lined cladding has also been found to reduce precipitation noise.

12.1.3 Thermal Noise

Nearly all profiled metal roofs will exhibit thermal roof noise at times. Typically, this is a relatively minor and uncommon event, and attracts no attention. Sometimes, however, the frequency and/or volume of the noise can be to the point where it causes discomfort and distress to the occupants.

Thermal roof noise is caused by the roof expanding or contracting due to temperature fluctuation. The effect can be immediate as a cloud passes over the sun or delayed as the roof and roof structure cool down at night.

Not all materials in a roof structure absorb the same amount of heat, and not all materials have the same amount of thermally-induced movement. Differential movement may emanate from many places, including the layer of roofing exposed to the sun against layers underneath (i.e. a flashing or lap), the roof profile against the fastener, or the roof against the support structure. It can also happen when expansion of the roof causes one member of the support structure directly to move against another. Movement may also occur as sudden popping in the pan of a profile that releases static friction and causes sound.

The source of thermal roof noise can be difficult to identify in many cases. However, roof noise can be divided into three main categories by source. They are:

- Flashings,
- popping of pan, and
- other causes of thermal noise.

Flashings

Where flashings are solid fixed to a vertical surface and to the cladding, differential movement between them and the roof may cause noise. Using clip-fastened systems allowing flashings and roofing to move independently to each other will help minimise noise associated with this movement.

Pan Popping

Oil canning, or canning, is the term used to describe visible waviness of the pan of a metal roof. It is most noticeable in roofs with wide trays but may also occur in secret fixed or trapezoidal profiles.

Pan popping is accompanied by canning, but not all canning jobs result in thermal roof noise. Canning is most prevalent in tray profiles, but popping roof noise is most often found with trapezoidal or secret fixed roofs.

- Canning can be minimised by good rollformer tooling design and adjustment, it can be exacerbated by variations in mechanical properties and shape of the coil.
- Even steel coil well within standard tolerances can have characteristics that lead to high levels of canning in

some profiles and tooling set-ups.

- Canning can also be induced by the building structure, a concave curve in the support structure will put the pan of the profile into compression and lead to canning.

To avoid canning problems, both the structure and the sheets should be inspected for straightness before installation.

Other Causes of Thermal Noise

Roof expansion noise can be caused by the energy released when the roof expands or shrinks relative to its support and sliding occurs at the fasteners, clips, purlins, or within the structure itself. The exact source of most roof noise is hard to identify.

A common observation of noisy roofs is poor contact between the purlin and the rafter due to insufficient pressure being put on the purlin when installing purlin screws, allowing the purlin to ride up on the thread. It may create a source of noise as purlins rotate under thermal expansion forces. Purlin screws should have a length of unthreaded shank below the head of at least the purlin thickness.

12.1.3A Roof Noise caused by timber shrinkage



It is impossible to prevent expansion, but its effects can be minimised.

Thermal variation can be inhibited by using lighter colours or ventilating the roof space. Lowering roof temperatures minimises thermal noise. Increasing ventilation in the ceiling cavity is the easiest way to lower roof temperatures and may have the added benefit of lowering roof space humidity.

The accumulation of stress can be minimised by avoiding excessive run length. Friction can be reduced by using low friction underlay and using oversize fastener holes to allow materials to move freely. Fasteners should be checked for over-tightening and eased if necessary.

Many roof noise problems are typically associated with long, low dark skillion roofs, but some noisy roofs have none of those design features. To date, the MRM have not recorded any instances of thermal roof noise with roofs fastened to steel purlins or frames.

Thermal roof noise is a modern problem. Although often attributed to the roof material, steel and the profiles we form it into have not changed. In one case, a noisy trapezoidal roof was replaced with a corrugate roof manufactured from imported material, and the noise problem remained.

Changes that have occurred in the industry include:

- roofs are screwed on rather than nailed,
- roofs are longer and darker,
- purlins are screw fastened not nailed,
- houses are more airtight and far better insulated,
- trusses have largely replaced rafters, and
- framing timber is lighter and younger.

It is possible that a number of these aspects contribute in complex ways to produce varying thermal expansion noise levels, but we certainly don't want to go back to nailed roofs and uninsulated houses.

The exact source of much roof noise is still a mystery. Auckland University is currently researching a scientific approach to identifying causes and solutions to roof noise.

12.2 Purlin Creasing

Due to improvements in colour coating technology, the level of reflection and retention of gloss is higher. It will become much less obvious over time as gloss levels diminish and dirt accumulates on the roof.

Overdriven nails or screws can produce visible distortion on the purlin line in the pan of trapezoidal profiles that cannot be easily remedied.

12.2A Purlin Creasing on Trapezoidal Profiles



Trapezoidal profiles with a wide pan manufactured from 0.4 mm steel and 0.7 mm aluminium are particularly susceptible to purlin creasing, and although it does not affect performance, their appearance can be aesthetically unacceptable

It is the responsibility of the roofing contractor to ensure that nails are not overdriven. A nail or screw should only be driven into the purlin to produce a 50% compression of the sealing washer or until the roof is firm.

Before fixing the roof cladding, the contractor should check the alignment of the purlins or girts. Purlins should be aligned within 5 mm tolerance of each other to avoid purlin creasing.

Purlins should be accurately positioned with their top face parallel to the rafter and should be fixed to a straight line.

When appearance is important or where wide pan trapezoidal cladding is close to eye level, heavier gauge cladding should be specified because light gauges such as 0.4 mm steel and 0.7 mm aluminium are likely to show distortion. Purlin creasing will happen on both concave and convex curved roofs if the recommended purlin spacings are exceeded, and great care should be taken to align purlins on such roofs.

Purlin creasing can be exacerbated by roof traffic. [14.6 Walking On Roofs](#)

All trapezoidal and secret fix profiles will exhibit purlin creasing to some degree, the extent to which it is noticeable depends greatly on the line of sight and light conditions, which can change it from being immediately obvious, to almost invisible. Purlin creasing can be minimised by design by specifying 0.55 mm, rather than 0.40

mm material, or selecting a profile with a narrower pan. Minimising roof traffic on G300 tray roofing will also help, but the only way to ensure that purlin creasing will not be an issue is to lay a roof on solid sarking, or by using a corrugate profile.

12.3 Flashing Buckling

As a rule, to minimise buckling, any dimension of a flashing should be a maximum of 300 mm between folds. Even so, transverse flashings such as ridges and aprons can exhibit some waviness due to the combined effects of thermal movement and timber shrinkage.

The only way to eliminate this is to fasten ridges on a hot day to dry timber. As this is seldom practical, light evenly spaced waviness in a ridge or transverse flashing is not considered a defect.

Being highly visible, waviness in barges and external corner flashings can be more problematic. In a situation where there is a low tolerance for waviness, flashings should be designed to keep the width of flat surfaces minimal and to be clip fastened on both edges to accommodate movement. Where possible, manufacturing from a heavier gauge material will also help minimise buckling.

Severe localised irreversible buckling of a flashing caused by compression wood is the result of a defect of the structure and should be rectified. See [8.9 Compression Timber](#).

Flashing Buckling



12.4 Oil Canning

Distortion of flat metal areas is an aesthetic problem associated with the manufacture of metal roof and wall cladding and flashings. Flat pan architectural metal panels, wide flashings, and profiled metal cladding with wide pan configurations without stiffening ribs are all liable to show distortion in flat metal areas. It is known as oil-canning or panning.

Oil canning can be defined as visible waviness in the flat areas of metal roofing and wall cladding. It can also be referred to as panning, canning, stress wrinkling or elastic buckling, and is caused by differential stresses in the metal. As the metal tries to relieve these stresses in panels with high width to thickness ratios, material buckles out of plane producing the characteristic waviness of oil canning

It has an aesthetic effect and is not a structural or durability issue. Some highly reflective paint finishes and metals or different light conditions can exacerbate the visual effect of oil canning. Some distortion is inevitable in light gauges. It can become an issue of customer acceptance because customer expectations are often unrealistically high.

The degree of waviness can be hard to measure and is highly dependent on viewing angles, the position of the sun, and the reflectivity of the surface. Cladding installations with a high degree of visibility should be designed to minimise oil canning.

Oil canning is more common where the width of unformed sections is large. It can usually be avoided or minimised in normal rib and trough section profiles with a maximum pan width of 300 mm, and flashings that have a maximum unformed width of 300 mm. See [8.1 Flashing Materials](#)

In standing seam roofs with pan widths of more than 300 mm, some oil canning is normally evident. Many designers regard oil canning in such profiles as inherent to the material and treat it as a desired effect accentuating the material's natural characteristics.

Manufacturers and installers should minimise unintentional non-flat conditions, and any visual waviness should be relatively even and regular.

There are various causes for oil canning:

- material;
- roll tool design and setting;
- installation; and
- expansion allowance.

12.4.1 Material

All profiled metal roof and wall products begin in a coil form. Stresses induced during coil production can contribute to oil canning. Examples of these stresses are:

- Full Centre: The coil is longer in the centre of the strip than near the edges. This creates buckles and ripples in the mid-coil area.

- **Wavy Edge:** The coil is longer on one edge of the strip. That causes waviness on the long edge.
- **Camber:** The side edge of the coil deviates from a straight line. The normal tolerance for a 1200 mm wide coil is a 2 mm deviation in a 2 m length, but some forming processes and end uses cannot tolerate that variation.
- **Uneven Material Strength:** During the forming process material may tend to draw unevenly from the softer areas rather than evenly as designed; it leaves excessive material in the “harder” areas.
- **Slitting:** Generally, coil for flashings and narrower products are cut by slitting from a single, wider master coil. Slitting of a master coil can release and redistribute residual forces. It can also mean that different qualities of the master coil are modified or changed in the slit coil, i.e., a full centre in a master coil can become a wavy edge in a slit coil and the slit coil may not retain all the attributes of the master coil or sister coils.

12.4.2

Tool Design

By the nature of the process, many stresses are created during roll forming. These must be minimised and equalised as much as possible during manufacturing. Forming tools must be designed to form the material progressively.

Corrugated and ribbed profiles are most often formed from the centre and moved outward thereby “pushing” the differential stresses to the edges of the sheet. Generally, profiled metal rib and corrugated profiles, flashings, and most trough sections can be expected to provide finishes free of avoidable distortion.

Standing seam profiles typically need more forming on the edges of the feed material and little or none in the centre of the sheet, which tends to trap uneven stresses in the centre of the profile. Often one edge requires more forming than the other, meaning the stresses developed are not even in the sheet.

Some evenly distributed oil canning can normally be expected in standing seam products with a width of more than 300 mm, and it is considered acceptable.

12.4.3

Installation

Oil canning can occur in fixed cladding, even though it does not fit accurately, when fixings are too far apart or when fixings are overdriven. It can also result from an uneven substrate, irregular bearing on the purlins or by the structural framing being out of line.

Thermal expansion can also increase oil canning. Longitudinal expansion should be accommodated by using sliding clips allowing movement. See [E Expansion Clips](#). Transverse expansion is usually accommodated in the upstand of the profile, but this can only happen if adjacent pans are not in contact at the base. Wide perimeter flashings must be designed to allow for independent movement of the flashing and the cladding.

A convex curve in the roof structure can cause canning as it puts the pan of the profile under compression. Sometimes this curve is inadvertent. Concave roof cladding and flashings give rise to oil-canning because the pans are in compression. There are limitations on curved radii to avoid oil canning. See [15.1 Curved Roofs](#).

Commercially designed truss sections and rafters may have camber induced in their manufacture, anticipating deflection under load. The degree of curve that may be accommodated by any profile is largely determined by the width of the pan and is, also, affected by the material thickness and grade.

12.4.4 Minimising Oil Canning

Good design and installation can minimise oil canning.

Materials:

- Use thicker material.
- Use low gloss paints or embossed surfaces.
- Use natural weathering materials that dull over time.

Flashings:

- Limit flashing width to 300 mm.
- Limit the joined length of fixed flashings to 12 m.
- Attach wide flashings with brackets that allow independent thermal expansion.
- Manufacture a stiffening swage into flashings that have a face width greater than 200 mm.
- Do not fix flashings to timber with a moisture content greater than 18%.

Cladding:

- Limit cladding length.
- Ensure the purlin alignment avoids convex curving.
- Inspect for flatness before installation.
- Avoid thin materials.

12.5 Colour Differential

It is both the cladding manufacturer and the roof cladding contractor's responsibility to ensure that the same brands of pre-painted material are used on the same building.

Failure to do so could result in differences in colour, gloss and weathering, which quickly becomes obvious.

The differences come from different paint formulations and do not necessarily indicate that the materials will perform differently in service. All New Zealand manufacturers provide information about the manufacturer, the type of coating and the manufacturing date in the branding on the reverse side of uncoated and colour coated steel. Double-sided coatings are not branded.

12.5.1 Touch-Up

Air-drying touch-up paints have different weathering characteristics to the baked-on finish of pre-painted coating systems and variations in natural light conditions will emphasise these differences, producing an unacceptable aesthetic appearance.

Spray cans should not be used for repairing scratches on pre-painted sheeting.

If the scratch is obvious from 3 m, the sheeting should be replaced, if not then it should be left alone. Minor surface scratches become less noticeable as the coating weathers and are best left as they do not appreciably affect the corrosion inhibiting properties of the material.

Widespread damage caused by rough handling or an accident, however, should not be corrected by repainting, but the affected material should be replaced.

12.6 Transport, Handling And Storage of rooflights

All roof lights should be handled and stacked with care as film surfaces are easily scratched, and heavy stacks can damage lower sheets.

All roof lights should be stored flat, the right way up, on 75 mm battens not more than 1.2 m apart. Stacks should not be higher than 1 m and should be covered and protected from rain and sun.

Thermoplastic sheets can overheat and deform in a stack, and exposed stacks can permanently discolour due to the effect of sun and water.

12.6.1 Maintenance

First maintenance after 12 months requires cleaning any grime or debris using warm water and a stiff bristled brush. Every 2 - 3 years rooflights should be inspected for damage, the condition of the flashings, and sealants and the fixings should be checked for tightness.

Roof lights must not be painted over as this renders them hazardous to maintenance workers.

Because painted roof lights appear no different in place than metal sheets, this practice can be dangerous for any workers carrying out maintenance work on the roof. Painting can also cause heat distortion which can lead to premature failure.

As a warning, primary and secondary fasteners can be brightly coloured, providing a contrast with the remainder of the roof cladding surrounding the roof light areas. The area can also be marked around with a distinctly painted stripe.

Lichen will accumulate on plastic roof lighting wherever there is a source of nutrients, but it should be removed with care. See [16.7.1 Lichen And Mould](#).

12.7 Drinking Water

Rainwater collected from roofs clad with steel and prepainted steel products will comply with the provisions of NZBC G 1 2.3.1, provided the water is not contaminated from other sources.

The first 25 mm of rainfall from a newly installed roof should be discarded before drinking water collection starts, and always disconnect downpipes when painting a roof. Spouting should be regularly cleaned to avoid the build-up of dirt and debris that can affect water quality.

Where a paint or paint system is applied to the roof, its suitability for the collection of drinking water should be established. When rainwater from pre-painted roof cladding is used for drinking, it is advisable to repaint the roof as soon as its surface has weathered.

Water collected from metal roof cladding, spouting or gutters made from aluminium, copper and stainless steel will not normally be contaminated by rainfall in suburban and rural areas. However, fallout from manufacturing plants, top dressing, and the contamination resulting from roof cleaning can affect the water quality, and in these cases downpipes should be disconnected.

13

Safety

This section highlights some aspects of the New Health and Safety at Work Act 2015 (HSWA 2015), including:

- responsibility,
- working at height in New Zealand, and
- working on roofs.

HSWA 2015: Objective

The objective of The Health and Safety at Work Act 2015 is protecting the health, safety, and wellbeing of workers, and other people.

Information used in this section was retrieved from

<http://www.legislation.govt.nz/act/public/2015/0070/55.0/DLM5976660.html> and worksafe.org.nz.

13.1 HSWA 2015: Objective

13.1 HSWA 2015: Objective

The objective of The Health and Safety at Work Act 2015 is protecting the health, safety, and wellbeing of workers, and other people.

13.2 Responsibilities

The HSWA identifies four duty holders responsible for health and safety on site.

They are;

- PCBU's
- Officers,
- Workers, and
- Other People.

13.2.1 PCBU

The person conducting a business or undertaking (PCBU) is not necessarily one person. It is a business entity in most cases, but there could be more than one PCBU involved with a project; clients, principal contractors, and sub-contractors can all be PCBUs.

The 'Primary duty of care' of the PCBU is to ensure the health and safety of workers and anyone else who might be affected by the work done.

13.2.1.1 PCBU Responsibilities

The PCBU must (as far as reasonably practicable):

- Provide and maintain a workplace that is without risks to health and safety.
- Ensure the safe use, handling, and storage of plant, structures, and substances.
- Provide adequate facilities for the welfare of workers.
- Provide the information, training, instruction, or supervision that is necessary to protect all persons from risks to their health and safety arising from work.
- Monitor the health of workers and the conditions at the workplace to prevent injury or illness.

13.2.2 Officers

Officers are people (including chief executive officers and directors) who have significant influence over the management of a business. An advisor is not considered an officer.

Sole traders have the responsibilities of both a PCBU and an officer.

13.2.2.1 Officer Responsibilities

An officer must take reasonable steps to:

- Keep up to date about work health and safety matters.
- Understand the nature of the hazards and risks associated with the organisation's operations.
- Ensure the organisation has resources and processes in place to eliminate or minimise risks.
- Ensure appropriate and timely processes are in place for receiving and responding to incidents, hazards, and

risks.

- Ensure there are processes for complying with any duty.
- Verify that health and safety processes are in place and being used.

13.2.3 Workers

A worker is anybody who carries out work on behalf of a PCBU.

13.2.3.1 Workers' Responsibilities

Workers must:

- Take reasonable care to ensure the health and safety of themselves and others in the workplace.
- Comply with health and safety policies and procedures of the PCBU.

Workers have the right to refuse to undertake unsafe or dangerous work.

13.2.4 Other People

Other people in the workplace includes visitors and customers.

13.2.4.1 Other People's Responsibilities

Other People must:

- Take reasonable care for their own health and safety.
- Ensure that their acts or omissions do not adversely affect the health and safety of others.
- Comply with safety instructions and procedures issued by the PCBU.

13.3 Working on Roofs

Falling from height is the most obvious hazard associated with installing roof and wall cladding. There is a hierarchy of techniques and mechanisms for ensuring safety at height.

13.3A Working on Roofs Safety Systems

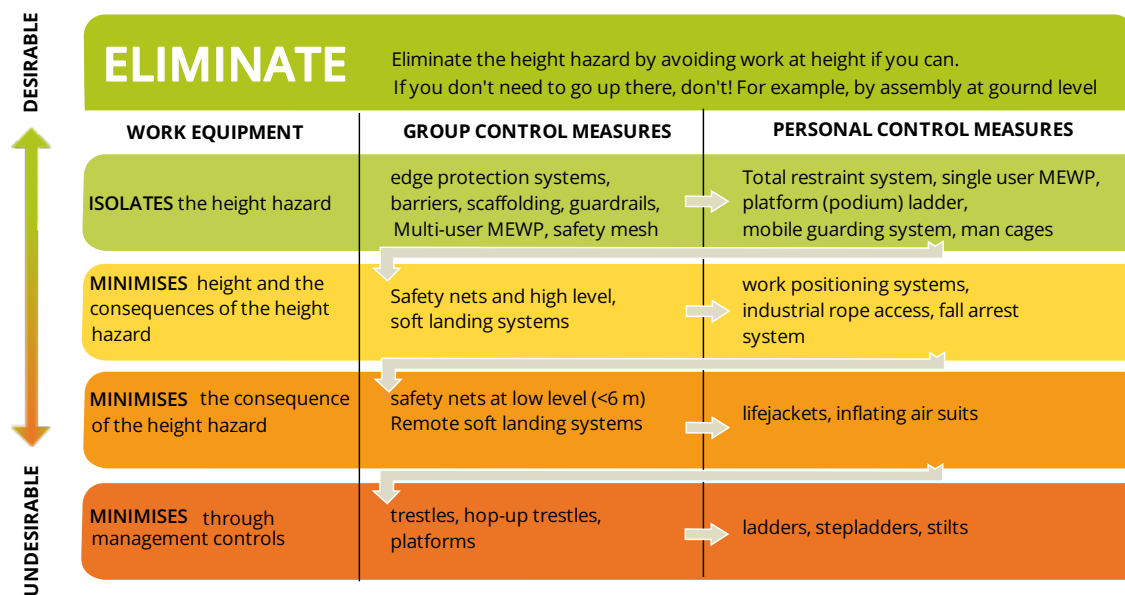

Source: MBIE Best Practice Guidelines for Working on Roofs: 2012

13.3.1 Safe Access to Roofs

Secure temporary access must be provided when there is no permanent access to roof areas. Preferred means of temporary access include scaffolding, constructed work platforms, or mobile elevating platforms.

13.3.2 Assessment of Existing Roof Cladding

Roofing material deteriorates over time. Before beginning any work on a roof, inspect the roof surfaces to determine its condition and identify weak spots (e.g., abnormal corrosion).

13.3.3 Weather Conditions

Weather conditions may affect working conditions adversely.

Adverse weather conditions include:

- moisture (dew, condensation, rain, or snow),
- high wind, and
- sun glare and UV radiation.

13.4 Working At Height

Source: *Worksafe: Working at Height in New Zealand*.

Many falls from heights are caused by a lack of planning. Dangerous situations can be improved by identifying, assessing, and managing hazardous situations.

13.4.1 Scaffolding

Scaffolds are a common way to provide a safe work platform.

- Scaffolds must comply with the Scaffolding, Access & Rigging New Zealand (SARNZ) Best Practice Guidelines for Scaffolding in New Zealand or equivalent guidelines or a higher standard.
- Scaffolds should be erected, altered and dismantled only by persons who have been trained and have suitable experience with the type of scaffolding in use.

13.4.2 Roof Edge Protection

Edge protection is used to prevent persons, objects, or materials from falling.

Edge protection may be:

- a proprietary (engineered) system,
- materials to form a guardrail or physical barriers,
- erected scaffolding that supports a temporary edge protection system, or
- a combination of solutions.

See <https://worksafe.govt.nz/topic-and-industry/working-at-height/working-at-height-in-nz/>

13.4.3 Safety Mesh

Safety mesh protects workers against falling through a roof while they are installing cladding; it should be used in combination with appropriate edge protection. For more information about using Safety Mesh, see <https://worksafe.govt.nz/topic-and-industry/working-at-height/working-at-height-in-nz/>.

Safety mesh should comply with AS/NZS 4389 Safety Mesh.

13.4.4 Safety Netting

Safety netting describes fall arrest systems using temporary netting. This must be designed and installed in compliance with **Worksafe: Best Practice Guidelines, Safe use of Safety Nets**.

13.4.5 Mechanical Access Plant

Mechanical Access Plant includes:

- mobile elevated work platforms,
- forklift platforms,
- crane lift platforms, and
- knuckle booms

13.4.6 Safety Harness

Safety harnesses may be of Total Restraint type or fall arrest type.

Total Restraint types are preferable, they protect a person from approaching an unprotected edge

Fall arrest or Positioning systems limit the distance a person can fall

All safety harness systems must be adequately anchored, and in fall arrest systems rescue planning must be developed prior to use.

13.4.7 Soft Landing Systems

These mitigate the effect of falls by providing an energy absorbing landing area. They are generally applied where potential fall height is low.

14

Installation

Metal roof and wall cladding should be installed as described in this section to comply with the NZBC and to qualify manufacturers' warranties.

14.1 Pre- Installation

The roofing contractor or supervisor must inspect a set of consent drawings and specifications, before starting to install metal roof or wall cladding. Any decisions departing from it should be agreed on and written confirmation signed before work begins.

Minor changes should be recorded by the council on the consent application, major changes must be approved by the council before execution.

Where specific details are not drawn, the roofer and the main contractor should agree on the execution of these details before commencement.

The roofing contractor is required to have safety provisions in place that satisfy the **HSW Act** before work is commenced

The supporting structure should be inspected; the purlins and girts should be checked to see they are in a true plane and securely fixed, all trimming completed for penetrations, and any work by other trades is completed.

Where roof and wall cladding intersect with other materials, the sequencing of work and responsibilities for weatherproofing must be agreed upon with the main contractor prior to installation.

14.2 Product Selection

The profile must be suitable for the strength requirements of the building, and appropriate for the minimum pitch, and the material selected must be suitable for the environment and be compatible with adjacent building materials. See [4 Durability](#).

Aluminium requires special installation details to achieve durability. See [14.20 Fixing Aluminium Sheeting](#) for more details.

14.2.1 Measuring

Measuring should take place once sufficient structure is in place to enable accurate calculation of lengths required. It is beneficial to make more than one measurement of any run to identify discrepancies and avoid errors.

14.2.2 Ordering

Cladding materials should be ordered with enough time to allow for manufacture and transport. Profile, thickness, colour, grade, and any requirements for labelling of bundles should all be clearly identified.

Do not mix products; different manufacturers use different paint formulations. Where different brands of pre-painted material are used on the same building, differences in colour, gloss, and weathering performance may appear immediately or over time.

14.2.3 Transportation

Load safety and protection is primarily the driver's responsibility.

Short sheets should be packed on top of longer ones, which should have end and edge protection to avoid cut-end damage to the sheets below them. Dunnage should be evenly spaced in vertical alignment. Bundles must be placed and secured to protect against damage from other materials.

For sheets that are exposed on the underside in situ, such as for unlined wall cladding applications, or have double-sided or fleece-lined coatings, protection must be given to prevent the dunnage from damaging the bottom sheet. This is normally achieved by the application of a short slip sheet with paper overlay.

14.2.3A Slip sheet with Paper Overlay

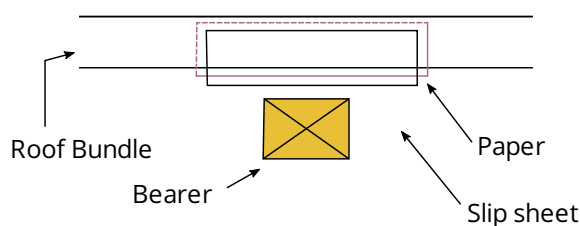

On longer distances, extra protection or packaging may be required to protect the material from fretting during transport.

For longer lengths, when a long boom is required for off-loading, a suitable boom should accompany the load unless otherwise arranged.

14.3 Accepting Delivery

Check the delivery to make sure you have the right product, delivered in prime condition. If there is any concern about the condition of the product, the supplier should be contacted before installation commences.

Ensure all components needed to complete the installation, including fasteners and accessories, are onsite before commencing installation.

14.3.1 Unloading

Set out a flat area and supporting dunnage to ensure sheets will not be damaged by site debris.

When unloading by crane, ensure the lifting boom has a spreader bar and that tightening strops do not damage sheet laps. Slings or strops should be nylon with leather sleeves to prevent fraying or cutting and damaging slings. Single slings and chains should not be used to lift packs of cladding.

14.3.1A Sling with Spreader Bar

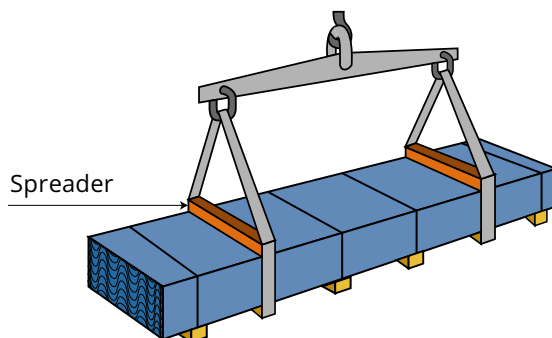

When unloading by hand, lift each sheet off the stack without sliding over under sheets, as that may cause damage to the paint.

The person receiving the roof is responsible for identifying a safe and convenient landing point for the load, in association with the main contractor. The mobile or truck mounted crane operator has the duty of declining any loading instruction which he deems unsafe. Under no conditions should the load be traversed directly above any person

Bundles or packs of roof cladding must remain banded when being lifted by a crane.

They must be placed adjacent to the portal frame and not mid-span on the purlins. Bundles must be placed so that their weight is spread over the entire area of the roof and should be positioned with the laps in the direction of laying.

Workers receiving a bundle of roof cladding on the roof must have sufficient mobility to avoid the load, and use tag lines to control the swinging of the load while it is out of reach.

Packs must be securely fixed to the structure.

14.3.2 Wet Storage Damage

Close stacked sheets may deteriorate quickly if water enters the pack. This happens because the metal exposed to moisture without air forms bulky, unstable, and loosely adherent, hygroscopic compounds. See [4.10.7 Crevice Corrosion/Wet Storage Stain](#).

Water can infiltrate deeply into a bundle of close-stacked sheets. The extent and severity of wet storage stain is usually proportional to the length of time the sheeting has been wet, however the time to onset can be very variable, and occur more rapidly in warm conditions.

Sheets can be dried by filleting sheets or cross stacking them on a slope to allow water to drain and air to circulate between the sheets. Only use a dry, well-ventilated environment for long term storage.

14.4 Site Safety

Installation of roofs presents many hazards including laceration, electrocution, puncture, and falling from a height. Prudent PPE and installation practices must be employed, and the guidelines of [Worksafe: Working at Height in New Zealand](#) must be followed. See [13 Safety](#)

14.5 Handling

Don't handle any roofing products roughly or carelessly; roofing products perform best when handled correctly.

- Don't drag or slide new sheets over other sheets or rough surfaces.
- All equipment and materials taken on to the roof should be clean and care taken to prevent damaging the surface.

14.6 Walking On Roofs

It must not be assumed that it is safe or permissible to stand on any roof structure or roof cladding.

The manufacturer of the roof sheeting must provide technical literature stating the point load limitations of the profile. The information must indicate the positions on the sheet where persons may safely walk or stand without causing damage or, alternatively, indicate the necessity to provide temporary walkways.

For roofs tested in accordance with MRM testing standards see 17.1 Metal Cladding Testing, a Restricted Access roof will withstand a 100 kg point load applied to the rib or over two pans, and an Unrestricted Access roof will withstand a 100 kg point load to a single rib at mid span. It must be taken into account that a worker laden with tools may weigh more than 100 kg, and impact loads can also contribute to exceeding this limit.

When access to the roof is necessary after construction, it is best practice to in the pan of the profile when walking up the roof, and follow purlin lines when traversing roofs.

14.6A Walking in the Pan

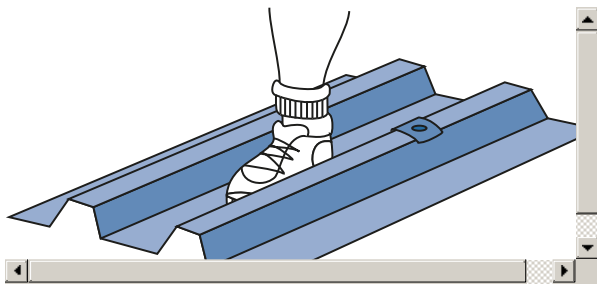

If ribs are too close together, so workers cannot place their feet in the pan, their weight must be spread evenly over at least two ribs when walking up the roof.

14.6B Spreading Weight over two Ribs

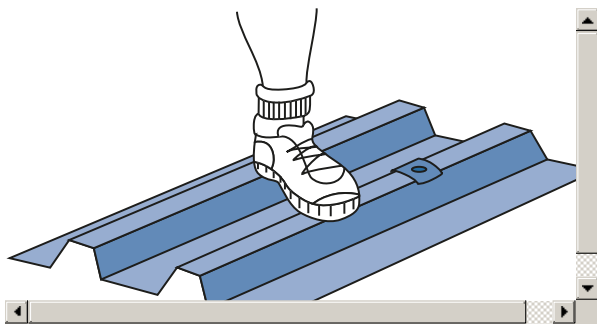

Translucent sheeting must not be walked on unless it is designed specifically for that purpose.

14.6.1 Footwear

- Anyone walking on the roof should wear flat rubber-soled footwear to prevent marking.
- Put an old mat or piece of carpet at the base of the ladder so that shoes can be cleaned before going up on the roof, or dirty shoes should be removed and replaced at base of the ladder.
- Smooth soled or open tread pattern shoes with good grip on smooth surfaces should be worn when working on a roof. Avoid the closely ribbed type which will carry swarf and other objects.

14.7 Strippable Films

Strippable film is a clear pressure sensitive polyethylene plastic film that is applied to some roofing products to assist in protecting the surface from damage and scratching during forming, transportation, handling, storage, and erection.

Strippable film is designed to provide some protection to the product before and during installation on the building. It is not designed to protect against corrosion, humidity, or chemicals.

Strippable film must be removed before prolonged exposure to sunlight, as that may make it extremely difficult to remove. Prolonged exposure and wet conditions can also cause the film adhesive to whiten and breakdown, leaving residue on the painted surface when the film is removed. Once removed from the sheet for installation, strippable film must be collected and removed from the site.

14.7.1 Storing Product with Strippable Film

Product with film applied must be stored at temperatures of less than 50°C and out of direct sunlight to avoid prolonged UV exposure.

The product needs to be kept dry to prevent moisture ingress between the film and the painted surface. In the long term moisture ingress may cause issues to the painted surface; and in the shorter term cause the film adhesive to whiten and breakdown, leaving residue on the painted surface when the film is removed.

14.8 Double Lapping

Sheets should not be laid with a double lap, as this can cause accelerated corrosion in the lap area. If the remaining area of a roof or wall section to be covered is less than a standard sheet width, the sheet should be cut lengthwise to fit the gap.

Similarly, when replacing a roof without removing existing flashings, for example apron or chimney flashings behind cladding, the area of the retained flashing should be reduced by cutting back to the minimum practically achievable.

If a roof sheet lap requires extra protection, for instance when over the apex of a barrel curved roof where pitch is less than the minimum stipulated for the product, laps should be sealed rather than double-lapped. Lap tape is preferred over gunned sealant for this purpose, as it is less likely to become displaced while positioning the sheet.

14.9 Setting Out

Underlay support if required must be installed before laying of roof sheets commences, and underlay may be cut to length before use.

Laying should commence considering building sequence, prevailing weather, and architectural details. It is not necessary to face laps away from prevailing wind direction as roofs must be designed to withstand weather from any quarter. On critical jobs or when using curved sheets, it is advisable that side laps face away from the line of sight.

Sheets should be laid square to the nearest architectural feature, and regularly checked to correct any misalignment of sheet or squareness of structure. Laying out of square will result in saw-toothing of the eaves line. Saw-toothing of greater than 5 mm may be trimmed back to form a straight line.

14.10 Marking and Cutting

Black lead pencils must never be used for marking aluminium/zinc, and unpainted or pre-painted steel products. The carbon in the pencil promotes corrosion which will etch the surface of the material, leaving a permanent mark. Use a pencil of any colour other than black, a marker pen, or crayon.

Cut pre-painted steel material with care to avoid marring the high-quality finish. Cut by shear only – use nibblers or hand shears. Friction blades and high-speed saw blades must not be used on metal cladding. These blades will damage both the metallic coating and the pre-painted steel surface by creating excessive heat, and generate large amounts of hot swarf which will get embedded into the coating surface

All debris must be swept off the job at the end of each day. Prevention of swarf damage is far easier than its cure. (See [14.19.4.1 Preventing Swarf Damage](#)).

14.11 Overhang

The length of the overhang of sheeting into a gutter or spouting depends on the pitch of the roof and the site exposure to wind and rain.

The recommended overhang for roof cladding with a pitch between 10° and 35° is 50 mm, and 40 mm is regarded as suitable for a roof above 35°. When the ends of the ribs are not baffled by a spouting and the pitch is below 10°, the overhang should be increased to 70 mm to avoid blow-back.

14.11A Minimum Overhang

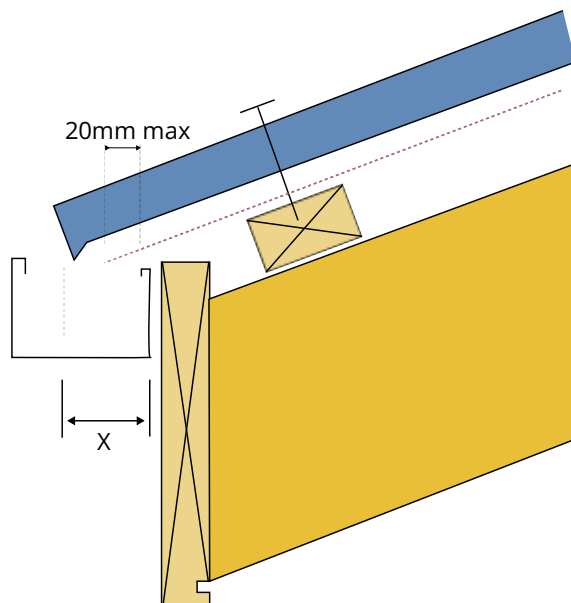

$X = 50 \text{ mm @ } 10^{\circ} - 35^{\circ}$
 $X = 40 \text{ mm @ } >35^{\circ}$

Underlay must not overhang the gutter line by more than 20 mm, or if eaves flashings are used, terminate on the upper side of the flashing. Do not drape underlay into the gutter.

14.12 Sealing and Joining

- Soldering cannot be used on aluminium-zinc materials; use only neutral cure silicone rubber or MS polymer sealants.
- Pre-align the pieces to be joined and pre-drill if possible.
- Thoroughly clean off surplus sealant and swarf using a dry, lint-free cloth or plastic scraper.
- Apply two beads of sealant close to each edge of the joint.
- Align pieces together and fasten with rivets at 50 mm centres.

14.12.1 Sealing End Laps

End laps in profiled metal roofing should be avoided where possible. When unavoidable, the end lap of should be sealed with a double bead of sealant as in the illustration below. Alternatively, self-adhesive closed cell tape can be used in the same position.

14.12.1A Sealed End Lap

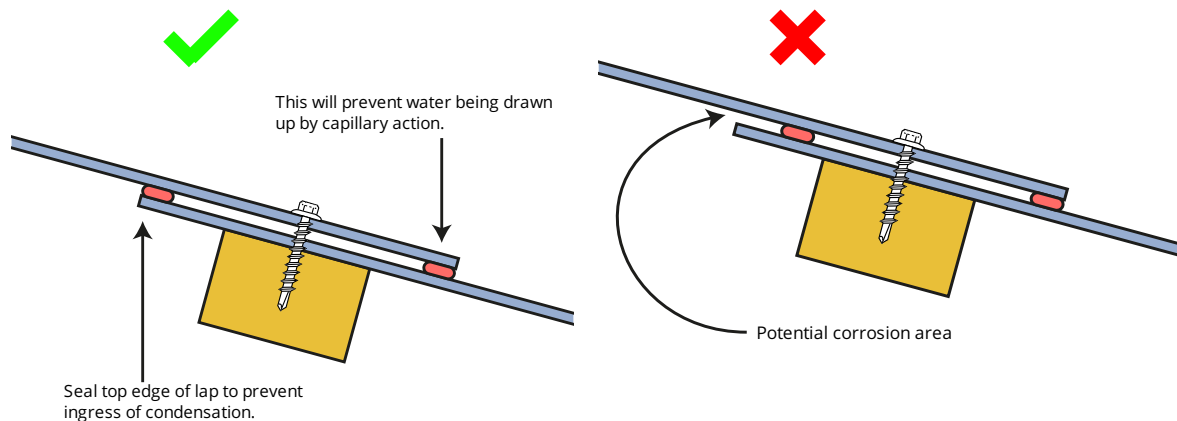

14.12.2 Side Laps

Side laps should be fitted evenly and snugly without excessive gaps or tension. Sheets exhibiting edge wave should be reported to the supplier immediately. Where a sheet width exceeds the distance to the next architectural feature, it should be slit to width; not given multiple overlaps to decrease its effective cover width.

14.13 Fasteners

The durability of fasteners should equal or exceed that of the material being fastened, and the fastener metal or coating must be compatible with the cladding material if in contact. Fasteners used pre-painted steel products should be factory colour matched before installation.

14.13.1 Nails

The traditional New Zealand roof fastener was until 1980 the "Lead Head", a flat-headed smooth shank steel nail with a lead head cast on it. Lead heads often 'backed out' causing leaks, the shanks were prone to corrosion, and lead is incompatible with modern metallic coatings. Spiral Shank nail fasteners have a galvanised shank, and the spiral shank has over twice the withdrawal resistance of a smooth shanked nail. They are however still prone to backing out, and the under-head seal is not as robust as the neoprene seals used on modern roofing screws.

The COP recommends using screws rather than driven fasteners, in all cases.

14.13.1A Nail Pull-out

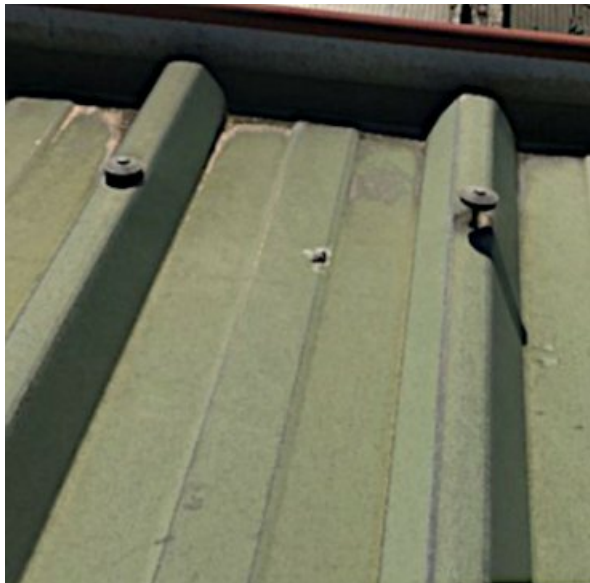

Driven Fasteners can back out over time.

14.13.2 Screws

Screw fasteners should be long enough to give adequate penetration into the supporting structure. Generally, 30 mm embedment is required for screws into timber or three threads engagement for screws into steel. Refer to roofing manufacturers for specific recommendations.

Fasteners should be:

- a minimum of Class 4 for Severe Environments,
- Class 5 for Very Severe Environments,
- manufactured and coated with materials compatible with the material being fastened, and
- fitted with low carbon, non-conducting sealing washers.

Profiled washers should have an EPDM sealing washer.

14.13.2A Screw Points

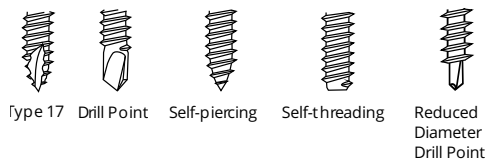

14.13.2B Screw Heads

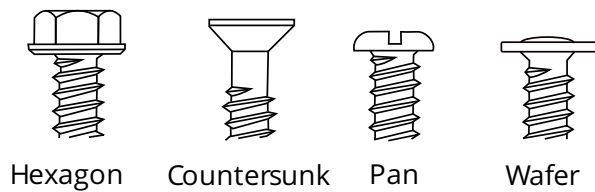

14.13.2C Screw Thread Types

Gauge	Diameters
	Nominal
	Shank
	mm
6	2.5
8	3
10	3.5
12	4.1
14	4.8

14.13.2D Screw Gauge

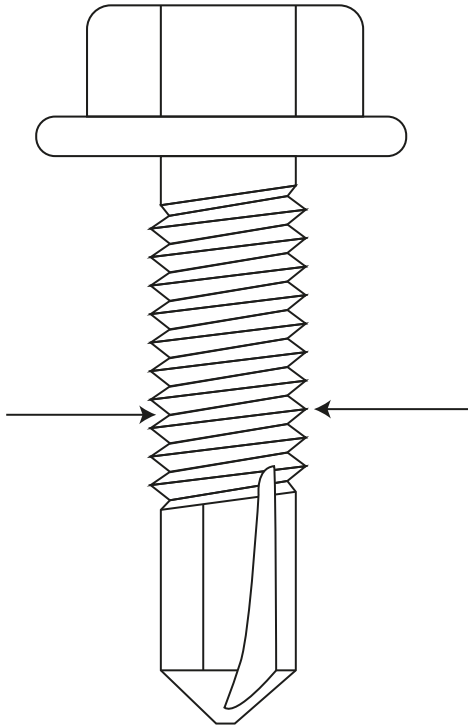

14.13.2E Threads per Inch (TPI)

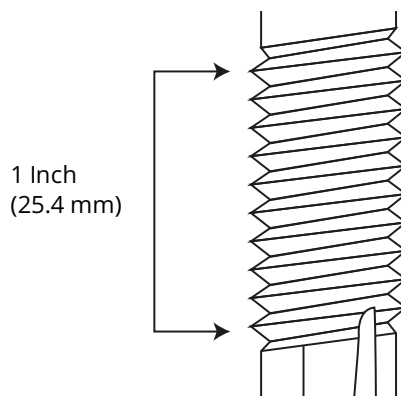

Screw fasteners are identified by their length, gauge pitch (threads per inch) and their drill point. The drill point may be type 17 for driving into timber or drill point for driving into steel. Reduced diameter drill points, which can be used for either function, are also available.

14.13.3 Clip Fasteners

Secret-fixed roofs will be attached to the primary structure by a proprietary clip that is screwed or nailed to the purlins. These profiles offer the advantages of fewer penetrations through the cladding, and thermal expansion is unimpeded.

Clip and bracket fasteners can be purpose made to provide the same attributes to most flashings.

14.13.4 Rivets

Rivets should have a minimum diameter of 4 mm.

Use aluminium rivets for galvanised sheets and aluminium/zinc-coated steel products; monel rivets are incompatible with aluminium and zinc products.

Sealed rivets are preferred over unsealed rivets, as they do not require adding sealant on the face to achieve weatherproofing.

14.13.4A Rivet Setting

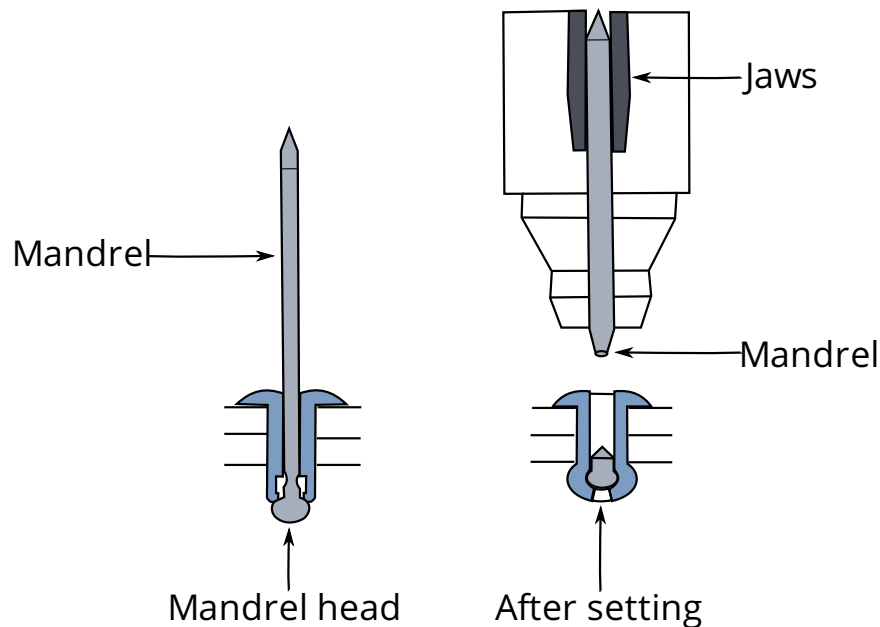

Blind rivets are placed through a pre-drilled hole then are set by rivet tool withdrawing the mandrel. This expands the rivet pin, clamping the material between the rivet pin and the rivet head. The pin eventually snaps free.

14.14 Fastener Installation

The correct depth setting on a screw gun is provided either by the depth gauge or by a clutch torque adjustment, and an adjustment should be made every time a different screw or material thickness is to be drilled. Resilient washers under fastener heads will only seal properly with the right adjustment.

14.14A Depth Setting

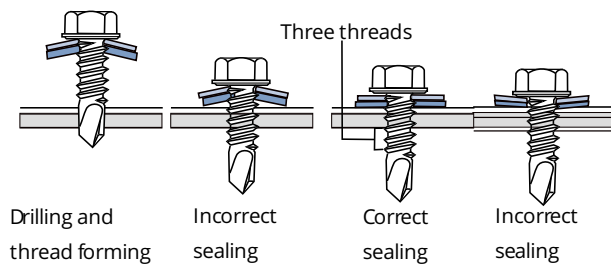

Experienced operators can, in most instances, drive screws correctly by using a variable speed screw gun; however, a depth set gun will give more consistent results.

Type 17 screws driven into timber will 'part' the fibres rather than cutting them which provides a self-locking action against withdrawal. Screws driven completely through timber will, therefore, not have the same pull-out resistance as screws with embedded tips.

Impact drivers and poorly fitting nut drivers can both damage the protective coating on the screw head which will affect durability. It is the roofer's responsibility to ensure the method of installing screws does not cause damage.

Screw points, method of driving, and thread design all have an impact on pull-out capacity; so in critical situations, the specific screw and method of installation must be specified.

14.14.1 Fastener Spacing

Fasteners should be of grade and type suitable for the application, installed at spacings required by design loads and manufacturer's recommendations.

On buildings constructed to NZS 3604, a consistent fixing pattern should be used on all fastener rows; for other buildings, higher fastener density may be required around the periphery. All purlins must be fastened to so that they each contribute to resisting uplift loads. See [3.9 Fastener Requirements and Overhangs](#).

Rivets on flashings should be placed at 50 mm centres.

14.14.2 Fastener Placement

Roof fasteners should be placed at the crest of the profile. Wall cladding fasteners can be placed at the crest or the pan. Pan fixing of wall cladding is more popular as the screw lines are less visible.

N.B. The pullover design values established by testing for pan fixing are more than twice those for crest fixing.

14.14.3 Fastener Seating

Fasteners should be seated snugly to give a good seal, without distorting the roofing profile. Any “pigtailed” created by the drilling process must be removed before seating the screw.

14.14.4 Fastener Allowance for Expansion

All roofing and cladding are subject to expansion and contraction due to temperature extremes. This is particularly evident with darker colours and long spans where the expansion may be as much as 8 mm for a 10 m sheet. Screws fitted with profiled washers to allow for thermal expansion must be installed centrally through a 9 mm diameter pre-drilled hole in the roof sheeting.

14.15 Modes Of Fastener Failure

On most pierce fixed roofs, mode of failure is likely to be pull-over. Where profiled load spreading washers are required to eliminate this, it is important that the specified washer is used. When fastening to light gauge steel purlins, thread strip out may be the lower failure point. The pull-out failure point is very dependent on drill point, thread shape, and pitch; it is essential in such cases to use a correctly specified fastener.

14.15A Pull-Over

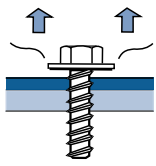

14.15B Pull Out



14.15C Thread Strip Out

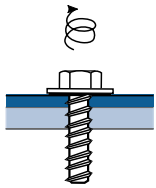

14.15D Back Out

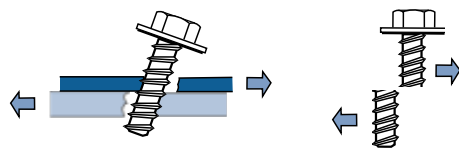
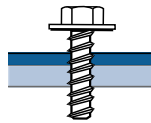

14.16 Stop-ends

Stop-ends are required at the upper end of all roofing sheets, on horizontal metal wall cladding and at the lower edge of penetrations

Stop-ends for trapezoidal profiles are of two types, i.e. 'dog-eared' or 'pull-up'.

Stop-ending tools should be in good condition so that they do not mark the coating. This is particularly important when using pre-painted material.

Stop ending can cause distortion of the pan adjacent to the turn-up, which can cause contact and mark the turndown of the cover flashing onto the pan of the cladding. This can be avoided by technique and experiment, often standing in the pan adjacent to the end being stopped will prevent the pan from becoming convex at this point.

14.16A Dog-eared Stop-ends

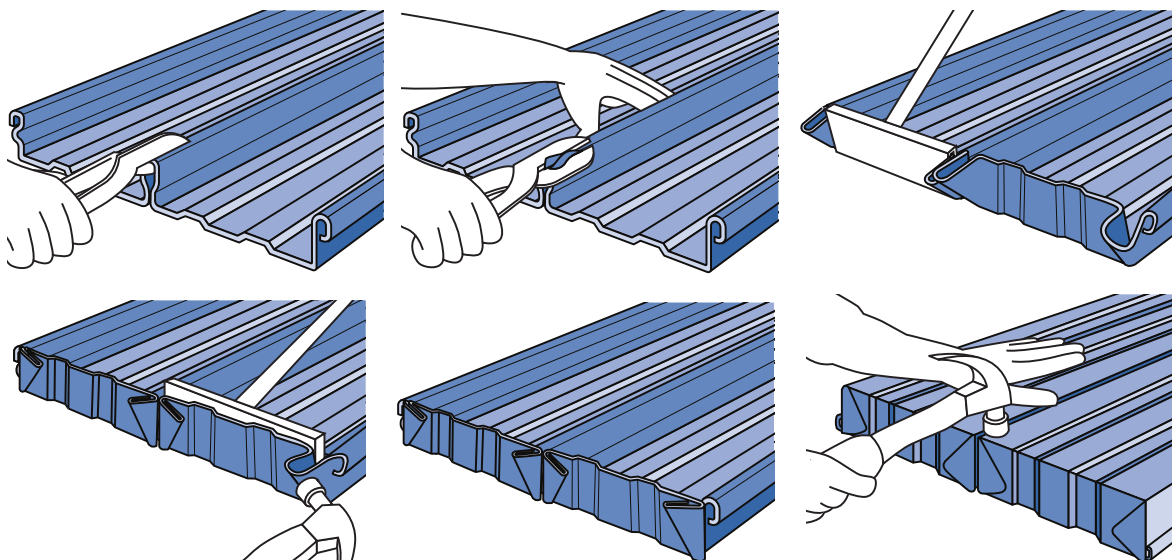

A 'dog-eared' or full stopend is made by cutting the rib back to the height of the profile so the material can be dressed and "wrapped around" 90°. It is not possible to dog-ear stop-end many profiles because of the shape of their rib.

To create dog-eared stop-ends:

- *Slit all ribs to a length equivalent to their height.*
- *Cut away the tops of the ribs at a slight upwards angle and remove.*
- *Insert turn-up tool to full depth and turn up more than right angles.*
- *Knock dog's ears flat on a stop-end tool as shown.*
- *Ensure tray is lying flat*

The rib height should be added to the sheet length when the material is ordered to provide an allowance for a full stop-end.

14.16B Pull-up Stopends

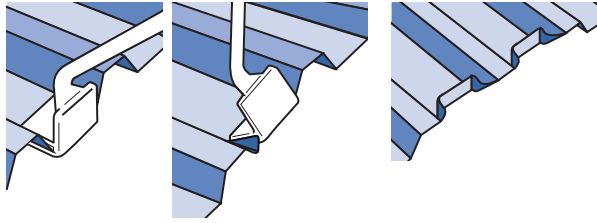

A 'pull-up' stop-end is not cut back but pulled up to the maximum allowable height without tearing the metal. No extra material allowance is required for a 'pull-up' stop-end.

14.16C Corrugate Stop-ends

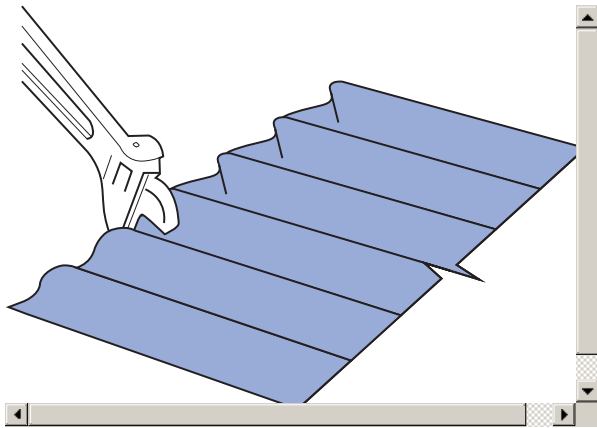

Stop-ends for corrugate should be pulled up to the full height of the profile, and on low pitches at exposed sites, additional weathering may be provided by the use of filler blocks. See [8.8 Profile Closures](#).

14.17 Turndowns (Drip Forming or Drip Edging)

All roof cladding with a pitch of less than 8° must be provided with turn-downs after the roof is fixed, using special tools to ensure water flows directly into the gutter.

Where profiles that prevent turning down the pan (such as deep corrugated) are fixed at pitches of less than 8°, an [8.5.4.4 Eaves Flashing](#) must be installed.

14.17A Profile Turndown

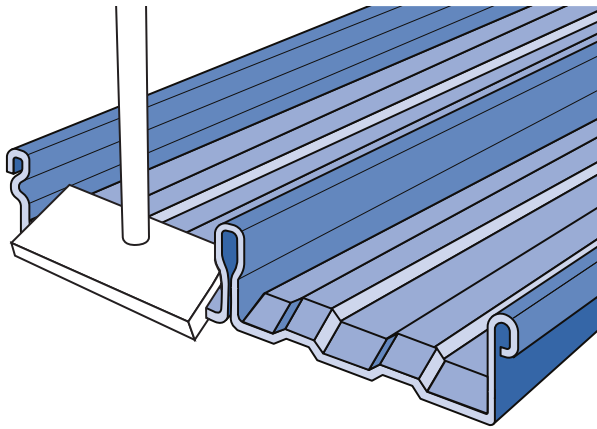

Providing a profile with a downturn will provide a positive drip edge and minimise the amount of sediment build-up at the gutter line.

Distortion should be avoided because it causes ponding and the collection of dirt, which in turn causes corrosion.

14.18 Soft edging and Flashing

The periphery of all roof planes should be sealed with a flashing.

Longitudinal flashings must cover one or two crests according to requirements. There should be a gap between the downturn and the adjacent rib to prevent capillary action and to allow for pressure equalisation. Both vertical and horizontal faces of the flashing should be fastened to other cladding or preferably, through the cladding to the structure.

Transverse flashings may be notched over the ribs of the profile, or for lower trapezoidal profiles or corrugate they can be fitted with a soft edging which is dressed into the pan of the profile. All soft edging must be colour matched to the roof before installation. Soft edging can be solid aluminium, solidly backed, or perforated to allow ventilation. The leading edge of transverse flashings must be through fastened to the primary structure, not riveted to the cladding.

14.19 Avoiding Problems

14.19.1 Roof Cladding Damage

Excessive downforce on a rib or corrugate crest can cause a compression fold, or “ding” in the apex of the crest.

Most roofs designed to Restricted Access criteria will incur some damage during installation or by subsequent traffic. If this is unacceptable, roofs should be designed to Unrestricted Access criteria and roof access and usage by other trades must be strongly managed and supervised.

A small ding in a sheet will not normally cause any structural problems and may be aesthetically acceptable, however deeper dings can cause cracking of the sheet and lead to leaks.

To restore a damaged rib load capability to the original levels all damage must be repaired with a cap flashing.

For aesthetic reasons, any damage may be unacceptable. However, if the roof cladding is not visible, ribs can be repaired by using a sealed and riveted saddle cap.

14.19.1A Sealed and Riveted Saddle

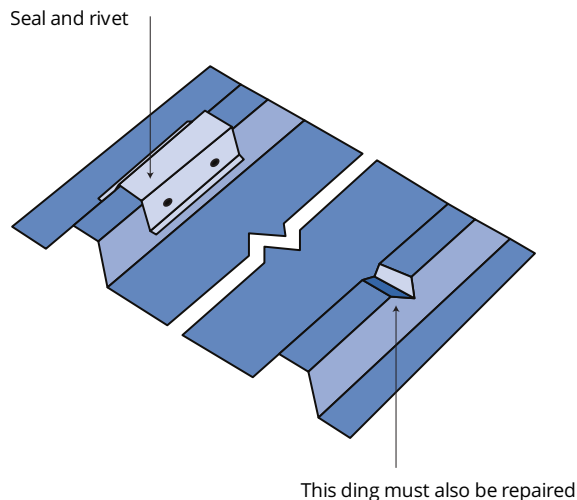

It is technically acceptable to have two dings or creases on one sheet within one purlin spacing, providing two adjacent ribs are not damaged. Any greater level of damage requires the sheets to be replaced, and the person who causes the damage must report it and be responsible for its repair.

14.19.2 Water Ponding

Ponding will create a prolonged time of wetness and increased build-up of debris. Ponding will detract from a coated steel product's life and will invalidate the product warranty.

The installation of penetrations must be done in such a way that they do not cause ponding. See External Moisture: Penetrations.

On low pitched roofs, careless or excessive foot traffic may cause rib damage and localised ponding. This can be minimised by installing temporary protection in critical areas, such as entry points, where the roof is accessed by other trades, or there is a step-down in the roof. It is the main contractor's responsibility to ensure that other trades do not damage the roof.

It is recommended to design to Unrestricted Access-criteria or better if roofs are highly visible or need to be regularly accessed by maintenance personnel.

14.19.3 Correctly Installed Gutters

Gutters must be installed with adequate fall to ensure water is transported to appropriately located downpipes. Fall and joints should be constructed so that water does not pond to a depth of more than 5 mm. Regular gutter cleaning and maintenance is required to remove leaves and other debris that may restrict water flow to downpipes. Vertical downpipes are parallel to wall and adjacent vertical references such as window jambs.

A gutter protection system (or any other product) that entraps debris or water between itself and any steel product surfaces, restricting coated steel's ability to dry, is not recommended and is an exclusion in the product warranty.

14.19.3A Incorrectly Installed Gutter Protection System



14.19.4 Swarf Damage

Swarf is the term given to the metal debris arising from cutting or piercing operations when using friction saws, drills, or other tools on roofing and cladding products. In this context, swarf may also include any other discarded steel objects such as rivet shanks, nails, screws, and nuts which may come into contact with cladding products.

Steel swarf particles left on the surface will corrode and cause rust stains which will detract from the finished

appearance of a project. These stains are often mistaken for early deterioration of the roofing and cladding itself. See [4.14 Swarf Staining and Cut Edge Corrosion](#).

14.19.4.1

Preventing Swarf Damage

Cutting

- Cut only by shear; power shears or hand snips produce the least amount of debris.
- Power nibblers give a clean cut but generate debris which if left is prone to corrosion.
- Do not use metal friction blades or reciprocating saws which produce fine hot particles which can embed deeply into the coating surface and corrode rapidly.

If metal grinding is taking place near the surface of an installed or uninstalled roof, careful masking of nearby coated steel surfaces must be executed.

Clean-up

Swarf should be swept or hosed from the job progressively and certainly no less than at the end of each day. Swarf that has become stuck must be removed carefully, avoiding action which is likely to remove or change the appearance of the paint or metal coatings.

When sweeping or hosing into a gutter, clean out the gutter before leaving the job to prevent premature corrosion. On completion of the job, give a final wash or sweep down.

14.19.4.2

Severe or Extensive Swarf Staining

If the coating is severely damaged by swarf corrosion, the area should be painted or replaced. The whole visible area should be repaired, as air drying paints weather more rapidly and in a different manner to pre-painted roofing and cladding products. If swarf particles are painted over, rust bleed-through is likely to occur.

14.19.4.3

Supervising Other Trades

A common cause of swarf complaints arises because other trades have used grinding equipment in the vicinity of a newly completed roof. Wind carried swarf can contaminate large areas some distance from the cutting site. Main contractors should be aware of the likelihood of such damage, and project planning should include scheduling of all cutting or grinding work to be completed before laying the roof cladding.

14.19.5

Colour Matching Paint

Colour match paint is designed for matching accessories to the pre-painted material; it is not designed for repairing marks or blemishes. The term touch-up paint should never be used. Fasteners and accessories requiring colour matching should be painted before installation.

Air-dried paints used to disguise marks weather at a rate different from that of pre-painted material, sometimes dramatically so, and will often become more apparent than the mark they are intended to disguise. Minor scratches are best left alone, and they will not affect the performance of the pre-painted product due to the self-healing qualities of the primer and metallic coating. They become less evident as the coating weathers.

Minor scratches may be described as scratches that do not extend to the metallic coating, are less than 3 mm in width, and are not visually noticeable from a distance of 3 m. This characterisation will, however, vary with the concentration of the scratches, and the visibility of the area affected.

Extensive coating damage to any pre-painted steel product can only be rectified by replacement or repainting of the affected sheets.

14.19.5A Visual Impact of Mismatched Paint



14.19.6 Field Painting

Profiled metal roofing and wall cladding are readily paintable using good quality primers and water-based acrylic topcoats. Metallic coated roofs can be painted immediately after installation; however, dirt, grease, and any loose materials must be cleaned off, so the surface is clean and dry before applying the first coat.

An effective method for painting metallic coated roofing is to apply a good quality galvanised iron primer and two water-based acrylic topcoats, following the manufacturer's recommendations.

Pre-painted products can be painted after exposure to weather. Normally, 6–12 months of exposure is required to achieve surface modification of the surface to allow the new coating to adhere.

Edge laps of unpainted metallic coated sheets steel do not require lap priming.

14.19.7 Sunscreen

Sunscreen containing titanium dioxide or zinc oxide can accelerate the degradation of organic materials including auto finishes and pre-painted cladding surfaces. This damage is irreparable, so prevention of its occurrence is the only defence. For more information contact the material supplier.

14.19.7A Sunscreen Damage

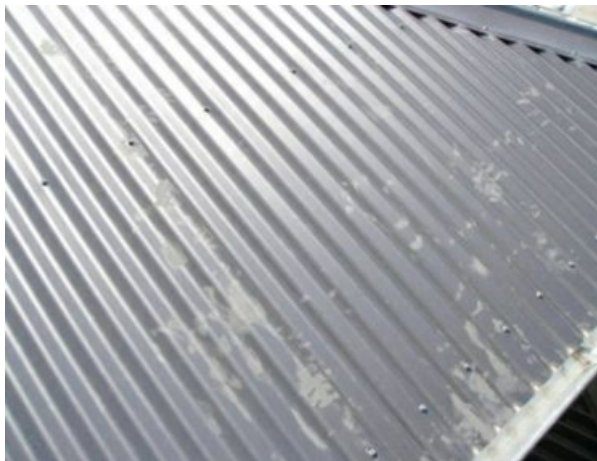

14.20 Fixing Aluminium Sheeting

Aluminium is a naturally durable material with proven performance over a long period.

Most metals compatible with Galvanised and Aluminium/Zinc coatings are compatible with aluminium. However, to acquire the required fastener durability, use aluminium or stainless screws rather than painted steel screws.

Aluminium has approximately twice the thermal expansion of steel, therefore, expansion provisions must be executed as for steel of twice the length.

Being soft and frequently requiring oversize holes for expansion, aluminium is typically fastened with fasteners equipped with load spreading washers, as is reflected in published span tables. Installers must adhere to published fastening systems to meet design load/span expectations.

14.20A Fixing Aluminium

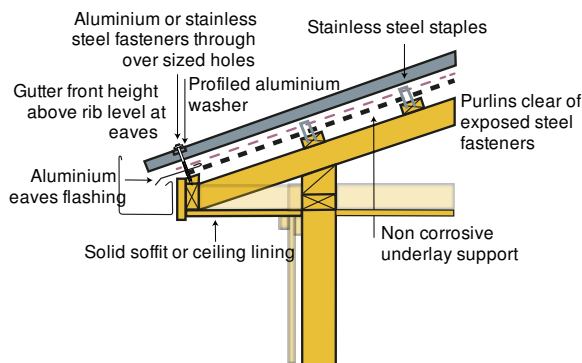

14.20.1 Painted Aluminium

Painted aluminium products perform differently than uncoated aluminium as the paint coating affects reactions with the atmosphere, and reduces the aluminium surface area that can be sacrificed to defend against localised corrosion.

Pit corrosion can result from damage to the paint coating and exposure to corrosive substances. It is necessary to protect against wet contact with concrete, treated timber, steel, stainless steel, and butyl rubber.

14.20.2 Recommendations for Fixing Aluminium

- The front edge of the spouting or gutter must be higher than the crest of the roofing profile.
- Eaves flashings of painted or unpainted aluminium must be used. Underlay should terminate on the top of the eaves flashing.
- When re-roofing with aluminium, the existing support members must be inspected to ensure all staples, wire netting, nails, or other materials likely to damage the aluminium have been removed.

- d. Galvanised netting or mesh must not be in contact with the underside of aluminium roofs. If present, it must be separated by a 5 mm barrier of inert non-absorbent, non-reactive material. Alternatively, self-supporting underlays may be used. Plastic strapping can be used for supporting underlays, stapled with stainless steel staples to the vertical face of the purlins.
- e. In a wet environment, aluminium must be separated from a corrosive surface such as concrete, butyl rubber, or CCA treated timber by using a 5 mm rigid strip of an inert non-absorbent material, an open woven geotextile layer, or PVC netting. Plastic coated steel netting is not recommended under aluminium sheeting.
- f. The design of the ceiling cavity must prevent the saturation of support members from internal or ground moisture. (See [10 Internal Moisture](#).)
- g. All screws should be fitted with a profiled or bonded washer. Fixing screws shall be aluminium or Grade 304 stainless steel. Stainless steel screws must be fitted centrally through pre-drilled oversized holes (9 mm) for roofing and walls, regardless of sheet length.
- h. For sheet lengths over 10 m, the capacity to allow for thermal expansion must be in accordance with the tables in [7.3 Thermal Expansion And Contraction](#).

14.21 Completion

The roofing contractor should notify the main contractor, architects or owner when he has completed the scheduled work. It is prudent if he records any damage to the sheets (or lack thereof) at this point, particularly if subsequent trades accessing the roof. Damage of any sort caused by other trades is not the responsibility of the roofer.

All gutters, valleys, roof channels and the roof cladding should be left clean and free from debris on completion of the work, and any roofing related debris on site should be safely removed.

14.22 Tools Of The Trade

14.22A Hand Seamers



Hand Seamers are used to hand fold small flashings, by progressively working along the edge of a sheet.

14.22B Seaming Pliers

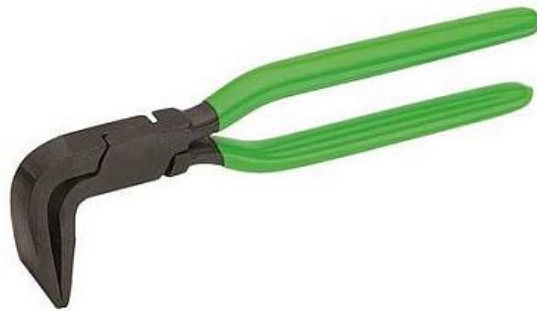

Various shapes of seaming pliers may be required to execute complex sheet metal work, particularly with standing seam roofs.

14.22C Crimping Tools



These can be used to form a small end in downpipes, or by reducing the length of a down-turn on a flashing to cause a curve in the adjacent surface.

14.22D Shears (Straight and Curved)

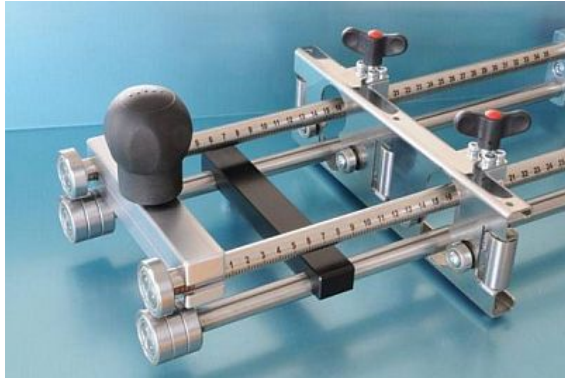

Shears are normally purchased in left-hand and right-hand sets. Both may be required to cut through complex shapes. They may be solid or articulated ("aviation snips")

14.22E Roller Bender

This can be used for onsite manufacture of flashings.

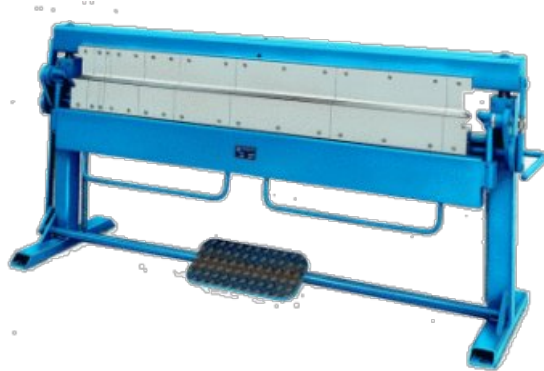
14.22F Portable Folding Machine

Portable folding machines are useful for onsite sheetmetal work.

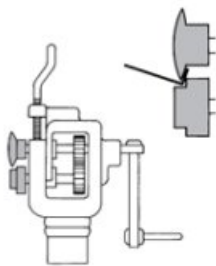
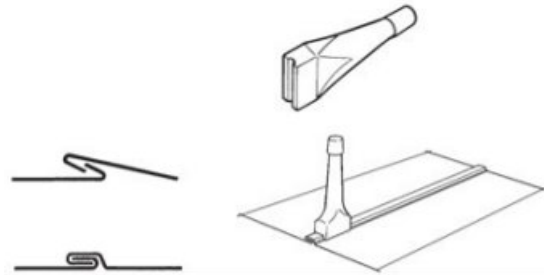
14.22G Hand Jenny Edger**14.22H Joint Sealing by Hand Seaming**

All metal joints that are to be sealed should be mechanically joined. Seaming is one acceptable method of joining two pieces of metal.

The two pieces are folded so each hooks into the other and then they are locked together by the means of a hand seamer or groover.

The material allowance depends on the hook dimension, but it is usually 6 mm. That means the extra allowance for the is 18 mm, because there are four thicknesses of material.

This type of seam can be used on a flat surface or round surface.

14.22I Setting Hammer

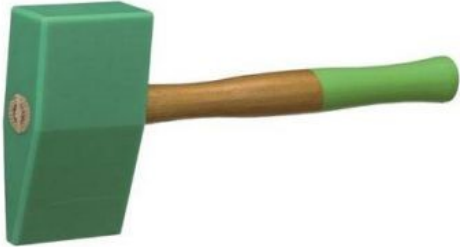

A nylon faced hammer can be used to reduce damage when dressing flashings.

14.22J Rivet Setter



14.22K Turn Up and Turn Down Tools



15

Other Products

Other roofing products, include:

- Curved Roofs.
- Solar Units.
- Pressed Metal Tiles.
- Standing Seam Cladding.

15.1 Curved Roofs

There are two main methods to clad curved buildings.

- 1. Draped sheets, known as spring curving.*
- 2. Pre-curved sheets, either roll-curved or crimp curved.*

For compliance with the requirements of the NZBC, designers should abide by the limitations of profiled metal cladding for curved roofs.

The curving process or crimping does not produce any strength enhancement for point or wind load. Curved roofs usually have maximum purlin spacings to avoid distortion.

Designers and contractors should be aware that light gauges such as 0.40 mm steel and 0.70 mm aluminium are likely to show distortion when used for curving. When asymmetrical-pan trapezoidal cladding is used for curved roofs and appearance is paramount, a heavier gauge cladding should be specified.

They are 'Restricted Access' roofs, which means that walking traffic should be restricted to within 300 mm of the purlins, and in the pan or over two ribs if they are adjacent to the vertical lap. Because of the changing pitch, edge protection must be provided, or a safety harness used when installing curved roofs. See [13 Safety](#).

All side laps of curved sheets below the minimum pitch for the profile must be mechanically fastened and sealed.

Curved flashings are described in [8.5.5 Curved Flashings](#)

15.1.1 Spring Curving

Spring curving, also known as draping or arching of roofs, is a method of providing continuous lengths of roof cladding over a curved roof structure from eave to eave without a ridging. It is suited to symmetrical roofing profiles of low rib height, which can follow a curve without excessive panning or distortion.

Because these profiles do not have a large rain- water carrying capacity they are limited in radius and length.

Maximum radius is limited to provide adequate drainage at the top of the curvature and minimum radius is limited to avoid distortion without pre-forming.

Asymmetrical and tray roof cladding can be draped, but only to a large radius before panning or distortion occurs and they are, therefore, unsuitable for all except large radii. They do not have the same restrictions on rain-water carrying capacity as symmetrical claddings. Because corrugate cannot be satisfactorily turned down into a gutter, wind pressure can drive rain up the corrugations, causing 'blow back' and allowing water ingress. Spring curved corrugate should not terminate below 8°.

Roof cladding must not terminate at a lower pitch than that permitted for the profile, unless the designer can demonstrate compliance with the NZBC by detailing an alternative method of weathering

and durability.

All trapezoidal and tray roof cladding below 8° must have the pan turned down into the gutter.

All roof cladding at all pitches must have either a pull-up or a dog-eared stopend.

If the width and height of the roof are known, this information can be used to obtain the radius of curvature and subsequently the sheet length and the length of seal required for any profile.

15.1.1A Recommended Radius for Concave and Convex Curves in Symmetrical Profiles

Material	Profile	10	20	30	40	50	60	70
0.40 HS	Corrugate	Shaded	Shaded	Shaded				
0.55 HS	Corrugate	Shaded	Shaded	Shaded				
0.40 HS	Trapezoidal		Shaded	Shaded	Shaded	Shaded		
0.55 HS	Trapezoidal		Shaded	Shaded	Shaded	Shaded		

15.1.1B Recommended Radius for Convex and Concave Curves in Asymmetrical Profiles

Material	Profile	30	40	50	60	70	80	90
0.40 HS	Trapezoidal					Shaded	Shaded	Shaded
0.55 HS	Trapezoidal				Shaded	Shaded	Shaded	Shaded
0.40 HS	Tray					Shaded	Shaded	Shaded
0.55 HS	Tray							Shaded

Only G550 MPa grade (HS) coated steel is recommended for drape curving.

The tables above for recommended radii assume the cladding is draped over an arc where the base chord is parallel to the ground. When the base chord is on an incline the maximum radius can be increased.

If the width and height of the roof are known, this information can be used to obtain the radius of curvature and subsequently the sheet length and the length of seal required for any profile.

15.1.1C Spring Curving Calculator

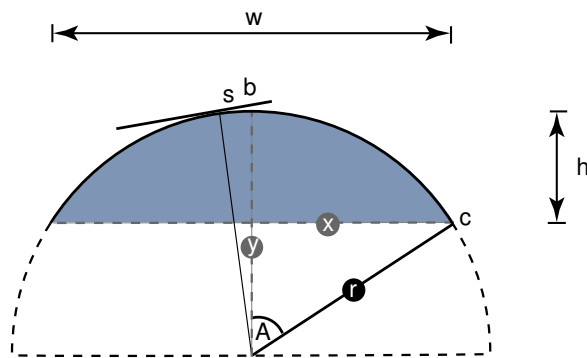

Definitions

- Width = w
- Height = h
- Radius of curvature = r
- Minimum pitch = p
- Sheet length = l
- Length of seal = s

The Code of Practice Online provides an interactive tool for these calculations. This tool is only available online at [15.1.1C Spring Curving Calculator](#)

Full Calculation Details and Example

Formula	Example
<i>Start with : w = Width of roof</i>	
w	= 12
<i>Start with : h = Height of roof</i>	
h	= 5

To find r the radius of curvature

$$r = \frac{4h^2 + w^2}{8h} = \frac{(4 \times 25) + 400}{40} = 12.5$$

To find *l* the sheet length

Find the length *y*

$$y = r - h = 12.5 - 5 = 12.5$$

Find the length *x*

$$x = \frac{w}{2} = \frac{20}{2} = 10$$

To find the tangent of angle *A*

$$\tan A = \frac{x}{y} = \frac{10}{7.5} = 1.33$$

To find angle *A*

$$A = a \tan\left(\frac{x}{y}\right) = a \tan(1.33) = 53^\circ$$

Find the arc length *c b*

$$c b = \frac{2 \pi r A^\circ}{360} = \frac{2 \times 3.1412 \times 12.5 \times 53}{360} = 11.56$$

Find the sheet length *l*

$$l = cb \times 2 = cb \ 23.12 + 100mm = 23.12$$

To find the length of seal

p = Min Pitch for corrugate = 8°

$$s = r \times (\tan 8^\circ) = 12.5 \times 0.1405 = 1.76$$

N.B. This length of seal is required on each side of the crest.
It is recommended that all profiles be sealed to 8°.

If the sheets are lapped laterally they must be sealed.

15.1.2 Laps

By definition, a curved roof is flat at the crest of a curve, and because it is below the specified minimum roof pitch required by the NZBC for unsealed laps, side laps should be sealed over the crest of the arch until the

minimum pitch is reached.

All vertical laps should be sealed if the pitch is less than the allowable minimum as tabulated below:

15.1.2A Curved Roof: Sealed Lap Pitch

Minimum pitch below which vertical laps should be sealed

Profile	Pitch
Corrugate	8°
Symmetrical Low Trapezoidal	4°
Asymmetrical Low Trapezoidal	3°
Secret-fix Tray	3°

When the pitch of the roof is below the minimum, the side lap is required to be sealed over the crown, and lap tape or silicone sealant should be placed on top of the rib and firmly held down while fixing takes place. Intermediate side stitching is required at the midpoint of all side laps using self-sealing rivets or stitching screws.

The side lap of profiled sheeting is designed with anti-capillary provisions to be self-draining. Before the continuous manufacture of corrugate from coil, symmetrical corrugate sheets were often laid with two nesting laps, which commonly corroded due to condensation, even when the laps were primed. All metal profiles now produced in NZ have capillary grooves. Trapezoidal profiles are designed for one lap only and corrugate used for roofing is designed for 1 1/2 laps with an under and an over.

Avoid double lapping because condensation can become trapped in the lap, which can cause accelerated corrosion with all steel products, including pre-coated steel. Lap priming should not be used as the permeable paint surface can retain moisture and accelerate corrosion.

15.1.3 Transverse Laps

To avoid a transverse lap, or if the sheet is longer than can be transported or safely handled, a step in the roof structure should be provided. See [8.5.4.3 Step Apron](#).

At a step or a lap, the end span must be reduced. See [3.5.1 Point Load](#).

If a transverse lap cannot be avoided, it must be mechanically fastened and sealed and must be made watertight from the inside by lap tape or sealant.

The sealant should ensure that the condensation flows past the joint and either be absorbed by the underlay or drain to the eave.

Severe corrosion problems have been caused on curved roofs by condensation running down the inside of roof cladding and into the laps. This was a common mode of failure when short lengths of galvanized corrugated sheeting were used in the past, but long run roofing without end laps has significantly reduced this type of failure.

Do not assume that the paint coating would provide barrier protection. The manufacturers' and industry requirement, since 1995, is to seal all transverse laps.

The time of wetness, which is a major factor of corrosion, is increased when unsealed metallic

coated steel cladding and flashing laps are subjected to a continuously damp environment. This situation is also detrimental to pre-painted metal cladding, which are attacked through the permeable paint coatings and at cut edges.

Where a draped roof is regarded as too long to transport or too difficult to handle as a drape curve in one sheet, the crown sheet should be as long as practical and the transverse lap should be placed as far down the roof as possible to increase the pitch at this point.

At the termination of curved sheets at minimum pitches in exposed areas, additional weathering is required at the turn down. Ventilated filler blocks and/or baffles should be used to prevent blowback, which can cause corrosion because the underside of the sheeting becomes an unwashed area.

Penetrations or end laps must not be placed in the region of the curve where the roof pitch is below the minimum pitch for the profile in [7.1.1A Minimum Pitch for Generic Metal Roofing](#).

Additional timber or steel supporting structure must be installed upside and downside of any penetration hole greater than 300 mm x 300 mm to provide fixing for the sheet and a reduction of the end spans.

Support must be provided to resist the uplift on sprung curved sheets at all penetrations.

All side laps of curved sheets below the minimum pitch for the profile must be mechanically fastened and sealed.

Continuity over a minimum of three purlins is required for successful drape curving and therefore any interruption, such as a penetration or other cutting of the sheet, may require machine curving to ensure the curvature is maintained.

Purlins must be accurately positioned with the top faces tangential to the radius of the arch and should be within a 5 mm tolerance to avoid purlin creasing. Roof traffic should be restricted to avoid damage, particularly in the low pitch region or in highly visible areas. Damage as a result of walking traffic can be seen as creasing at purlin lines or canning in the profile pans. Some purlin creasing is to be expected with stronger profiles, and at low pitches this can cause corrosion due to ponding. For convex roofs, the minimum radii should be adhered to because the pans are in compression, whereas with concave roofs the pans are in tension and the panning or distortion of these roofs will be less, although it depends on the profile.

15.1.3A Concave and Convex Compression

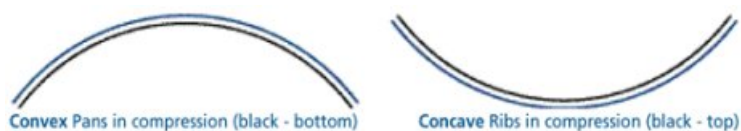

Only vented profiled filler blocks should be used at the eave on curved roofs so that some air movement is provided within the ribs. See [10.10 Ventilation Pathways](#).

Provision for expansion should be provided in the same manner as required for straight lengths, but the configuration of curved roofs means that some expansion will be taken up by a springing of the profile further up, which results in less movement. When the total sheet length is considered for

expansion, positive fixing using oversize holes, should be made at the crown.

15.1.4

Durability

When draped curve roofs are unlined and used as canopies or exposed eaves, the underside of the sheeting becomes an unwashed area. Therefore, it needs to be washed and regularly maintained to comply with the durability requirements of the NZBC and the supplier's warranty. The underside of pre-coated roof cladding is provided with a primer and backer coat only; it is not as weatherproof or UV resistant as the top-coat.

Because pre-painted cladding is not intended for use in this micro-climate without regular maintenance, the underside of the soffit should be lined in all severe and very severe environments.

(see [16 Maintenance](#))

15.1.5

Purlin Spacing

When the purlin spacing is close to the maximum allowable for the profile and ease of curvature, the roof cladding is more likely to be damaged by foot traffic and distortion between the purlins. When the radius of curvature is close to the minimum, the purlin spacing should be reduced to the end span distance for each gauge and profile. See [3.11.1 Steel Cladding Wind Load Span Graphs](#).

Access on curved roofs should be restricted and be regarded as Type B, and extra care should be taken during installation because of the changing pitch. Because some profiles used for curved roofs are close ribbed, it is not possible to walk in the pan. The walking pattern should be restricted to within 300 mm of the purlin and the load spread over two ribs. This is more important when low strength steel is used for pre-curved sheets.

Avoid using 0.4 mm G300 steel or 0.7 mm aluminium for roof cladding subjected to walking traffic.

The designer should consider the radius of curvature, profile, thickness, grade, and purlin spacing as these are all related parameters of curved roof design.

Maximum purlin spacings should be adhered to and any sheets damaged by foot traffic in the area below the minimum pitch for the profile should be replaced.

All curved roofs must have end spans reduced to two-thirds of the intermediate span, as required for straight roofs because the k_l load factor requires a reduction in purlin spacing at the roof edges. Where translucent sheets are required to be curved, the normal purlin spacings should also be reduced.

If the design loads are high, or where the eave is not lined and the roof cladding is exposed, extra fixings and load spreading washers are required.

It is important that the radii limitations and water drainage characteristics for specific products are considered at the building design stage so that water runoff over the low pitch region will not exceed the maximum for the profile used. The maximum radius of curvature permissible for corrugate and symmetrical profiles is limited for this reason.

Bull-nosed verandah or lean-to roofs, which are simply supported spans and do not have the continuity required for point load, should have their purlin spacings reduced to less than normal end spans.

Because the sheeting is continuous over the top of a curved roof and the wind dynamics are different, purlin spacings do not need to be reduced at the crest, as is normally required at the ridge on gable or hipped roofs.

The two top purlins should be placed to enable the sheeting to follow an arc that minimises purlin marking.

Draped curved roof or curved ridges should be fixed by fastening each sheet first to one side of the roof and then pull it down to be fixed on the other side. Alternate sheets should be laid in sequence to avoid cumulative errors and be laid from opposite sides of the roof to ensure squareness is maintained. Shift the two top ridge purlins to provide an even radius.

15.1.5A Laying Draped or Curved Cladding



Because extra uplift load will be taken by the end fasteners, screws and load spreading washers should be used on the penultimate and the last purlins and screws are the preferred fastener for curved roofs, although nails may be used on intermediate purlins.

Rafters and purlins must have additional fixing to the structure to resist the additional uplift load at the eave caused by curved sheeting.

Any assumed increase in span due to an increase in strength of the roof curve should be discounted, as concave and convex draped curved roofs are limited to the maximum purlin spacing allowable for the particular profile, and are dependent on the wind design load.

15.1.6 Concave Roofs

Roofing can be spring-curved into concave shapes; however, designers should be aware of the limitations on the minimum pitch where the curve is terminated. The extra uplift load that will be taken by the fasteners at the centre of the curve, and take into account the catchment area of the roof.

The pitch for concave roofs must not be less than 8° for corrugated profiles, 4° for symmetrical trapezoidal profiles, and 3° for other profiles. Screws and load spreading washers must be used for fixing cladding on all sprung concave curved roofs. The purlins must have additional fixing to the structure to resist the extra uplift load on sprung curved sheets.

The additional load produced by draping concave and convex metal roof cladding depends on the radius of curvature and the thickness of the metal. The induced load has two forces:

- *additional load on the fastener; and*
- *additional load on the purlin/rafter or truss connection.*

Although the former is the responsibility of the roofer, the COP recommends that the purlin connection is inspected for adequacy. Using a proprietary purlin strap can be an economical solution for the increased connection load.

15.1.6A Concave Roofs

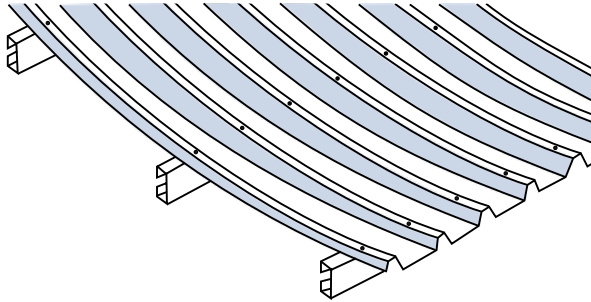

15.1.7 Pre-Curved Roofs

Low tensile metals and G 300 coated steel can be easily roll-curved in a pyramid rolling machine to small radii and can also be crimp curved into these shapes. See [15.1.9 Crimp Curving](#).

15.1.7A Bullnose



15.1.7B Barrel Vault



15.1.7C Ridge



15.1.7D Cranked Double Curve



15.1.7E Convex



15.1.7F Double Curve



15.1.7G Reverse Curve



15.1.8 Roll Curving

Pre-curved corrugated roof cladding is used for bull-nosed verandah roofs, ridges, or for roofs

where the radius is less than the minimum required for sprung or draped curved roofs. Corrugated (symmetrical sinusoidal) G300 roof cladding is easily curved or bull-nosed. The sheets are passed through matching curving rolls, which progressively form curves in a wide range of radii. If G300 and G550 steel sheets are to be used together, because these two materials will not have matching profiles, adjustment of the roll-forming machine setting is necessary.

Circular barns have been successfully cladded with 0.4 mm steel for many years, but 0.55 mm steel or 0.9 mm aluminium should be used for roll-curved roofs subject to foot traffic. G300 coated steel of 0.4 mm and 0.7 mm aluminium are only suitable for roofs without access or for wall cladding.

G300 steel can be curved to a radius as small as 300 mm using pyramid curving rolls. There is, however, a straight portion of about 80 mm at the end of the sheet which may need to be trimmed off if a true curve is required.

If the edge of the sheet is too flat or long, rippled edges may result, and these should be dressed out using a dressing tool or trimmed off before the sheet is installed.

15.1.8A Dressing Tool

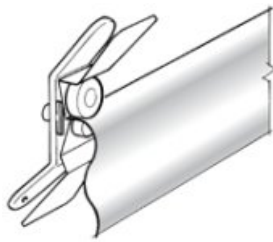

A curve can be rolled on one end of a straight length of roof cladding to provide an over or cranked ridge, but for ease of fitting and transport, a lap is usually made at the first purlin down from the ridge. This should be sealed in the same manner as is required for any transverse lap.

An alternative ridge detail can be used with straight sheets, without any lap, by roll curving or draping the cladding over the ridge, where the ridge purlins are extended their maximum span. For safety, roofs which are often used as a means of access to or onto a verandah should be provided with an intermediate support. Simply supported roofs cannot withstand foot traffic to the same degree as continuously supported sheeting.

15.1.9 Crimp Curving

Crimp curving is applicable to all profiles, but it is most suited to asymmetrical sections that cannot be rolled or drape curved.

Crimp curving is produced by pressing a small crimp in either the tops of the ribs or the pans of the sheeting. The profile is progressively shortened at these points causing it to bend. The radius can be altered by the spacing of and the number of crimps.

Some machines are capable of forming high-strength steel by a combination of compression and tension in the die design, and some machines require the use of strippable film as a lubricant to avoid coating damage. Where sheets are to be end lapped and different strength materials are used together, machine adjustment is required to

ensure an acceptable fit because their profiles are not usually consistent.

Fitting curved sheeting requires considerable care to ensure a satisfactory and aesthetically pleasing job. Setting out requires first checking that the materials delivered on site are within specified tolerances, and before commencing work the building should be checked for squareness.

The curving process can cause dimensional changes, which can lead to misalignment, so the sheets should be kept square with the building. Some minor saw-toothing at the gutter end is to be expected when fitting curved sheeting. When multiple curves are required that cannot be provided on one sheet, the sheets should be fixed in the order shown in [15.1.9A Fixing Order: Curved Sheets](#).

15.1.9A Fixing Order: Curved Sheets

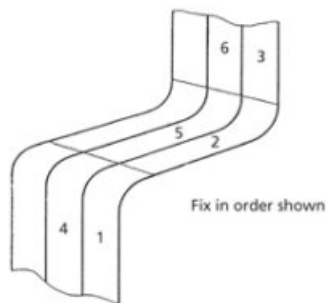

All transverse laps of crimped curved roof cladding must be mechanically fixed and sealed.

Some paint checking and microcracking is likely to occur at the crimps on metallic-coated steel cladding and these may show a white bloom. This is more readily seen in unwashed areas, such as when crimp curved sheets are unlined as a canopy or over a walkway roof. This area is required to be washed regularly under the maintenance provisions of the supplier's warranty.

The underside of colour-coated roof cladding is provided with a primer and backer coat only and if this is exposed in an unwashed area and can be seen, it should be post-painted with two coats of Acrylic paint. These areas are subject to maintenance as an unwashed area. (See [16.8 Overpainting](#)) Because the top of crimped sheeting is also subject to the collection of dirt and debris, particularly in the low-pitched area, it is subject to maintenance requirements.

All side laps of crimped curved sheets below the minimum pitch for the profile must be mechanically fixed and sealed.

15.1.10 Timber Fixing

When attached to timber purlins, the longitudinal wires of the safety mesh must be either bent down and fixed to the sides of the purlins or fixed to the tops of the rafters by 40 mm galvanised steel staples with a 3.15 mm diameter and spaced at 150 mm.

Staples must be driven so that a cross-wire is between the end of the wire and the staple, or the end of the wire is bent back and twisted four times around the same wire so that individual wires cannot be drawn from a staple.

15.1.10A Longitudinal Wires Passed Through Staples

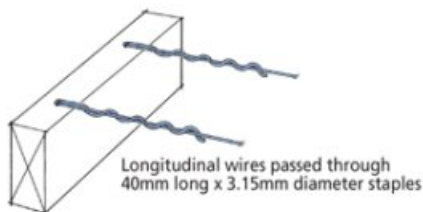

The longitudinal wires must be fixed to the purlins or rafters by galvanized steel wire loops of not less than 3.15 mm diameter. Place the centre of the tying wire around the longitudinal wire at an intersection, so that a transverse wire is between that point and the end of the longitudinal wire.

The tying wire must be passed once completely around the rafter, and then drawing the two tails of the tying wire in opposite directions over the two strands of the tying wire and twisting together with at least three complete turns.

15.1.10B Longitudinal Wires Wrapped Around Purlins

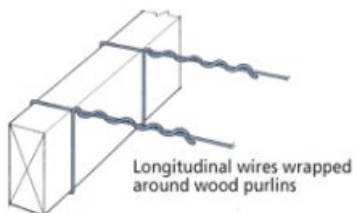

When joining rolls or sections, the two transverse wires must be placed together and the longitudinal tail wires must be twisted around each other. One longitudinal tail wire must be twisted four times around the main portion of the same wire. The other longitudinal tail wire must be twisted once around the main portion of the same wire and then four times around the two transverse wires

15.2 Mounting Air Conditioning, Aerials, and Solar Units

Structures mounted on the roof requires consideration of all the factors contributing to the performance of the roof cladding.

Some structures which are commonly mounted on roofs include air conditioning units, aerials, photovoltaic systems, and solar water heating units.

Design and installation of these structures should consider at least three areas of performance:

1. **Structure** – the effect of mounting the structures and roof traffic for ongoing maintenance; see [3.7.5 Dead Loads](#) and [3.7.4 Roof Traffic](#).
2. **Durability** – corrosion may result from issues such as wet contact, capillary action, unwashed areas, material compatibility, and runoff; see [4.10 Other Causes of Corrosion](#).
3. **External Moisture** – penetrations influence roof drainage and can affect weatherproofing of the cladding; see [9.3 Penetration Durability and Compatibility](#).

15.3 Pressed Metal Tiles

15.3.1 Design

Metal tiles, shingles and shake panels are press formed to provide a variety of shapes resembling clay tiles, wooden shingles or shakes. They are interlocked or overlapped laterally and longitudinally and are clipped or fastened to timber or steel battens.

Metal tiles, shingles and shakes are metallic coated steel are manufactured from metallic coated steel, although aluminium or other metals can also be used.

Pressed metal tiles made from steel invariably have an additional protective coating applied over the metallic coated steel. This may be an organic paint coating applied by either the steel manufacturer before the tiles are formed or by the tile manufacturer after the tiles are formed. An alternative coating can be provided by applying crushed stone or ceramic granules to the base metallic coated steel and attached by an adhesive coating; normally, a clear acrylic coat is used. These coatings give protection to the metallic coated steel base, as well as providing a decorative finish.

Pressed metal roofing tiles are installed by fixers, trained and appointed by the manufacturers or their representatives, and they are not normally supplied to other installers.

15.3.1.1 Durability

The principles behind detailed requirements for fixings, flashings, corrosion, compatibility, and maintenance as described elsewhere in this COP should also be applied to the design and installation of pressed metal tiles.

Exceptions result from the specific differences between tiles and other forms of metal roof cladding, and include the height of laps and specific dimensions of metal shingles and shakes prescribed in this section.

Steel based metal tiles, shakes, and shingles must have hot-dipped galvanised fasteners that are compatible with the base metal and provide a service life equivalent to the durability of the panel.

Panels are fastened to the roof structure by fixing horizontally through the front of the panel; and because the fixings are in shear, they provide wind uplift resistance suitable for very high wind design loads.

15.3.1.2 Pitch

Tiles with a minimum upstand of 25 mm must not be laid on roof structures less than 12° unless approved in writing by the tile manufacturer, the B.C.A. or the Territorial Authority.

Tiles, shakes or shingles with an upstand of less than 25 mm must not be laid on roof structures less than 15°.

N.B. The pitch of the roof is not the same as the pitch of the tiles because this varies with the height of the batten and the height of the upstand. If the minimum pitch cannot be complied with, a method approved in writing or a producer statement should be given before work is commenced.

15.3.1.3 Underlays

Permeable self-supporting underlay must be installed on all new roofs as specified in section 4.3. of this Code of Practice.

The underlay must be installed horizontally with a minimum overlap of 75mm.

The first length of underlay should be positioned so that it lays over the eave batten and the fascia, and into the gutter.

When pressed metal tiles are installed, the underlay is laid horizontally on top of the rafters before the battens are fixed, and so there is an air space between the underlay and the tiles, except at the eave.

15.3.1.3A Metal Tile Underlay

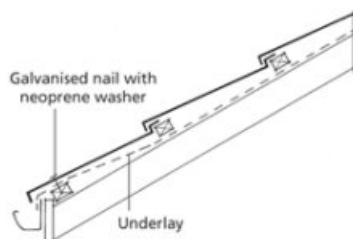

15.3.1.4 Roof Framing

Roof framing should provide support and fixing for the tile battens that will satisfy the design load wind requirements. Installers should check that the framing has been erected to an accurate and even line before roof fixing is started.

An inspection and any rectification to the framing alignment must be carried out before roof fixing is commenced.

15.3.1.5 Tiling Battens

Tiling battens must be:

- H1.1 boron treated when used in attic roof construction;
- H1.2 treated when used in skillion roof construction;
- Douglas fir with a moisture content of less than 20%;

- KD Pinus Radiata with a moisture content of less than 18%;
- a minimum of 50 mm x 40 mm for 900 mm rafter spacing; and
- a minimum of 50 mm x 50 mm for 1200 mm spacing.

Copper preservative timbers must not be used with Zinalume coated tiles. Battens required for rafter spacings greater than 1200 mm must be specifically designed and be spaced to suit the tile module.

Battens at 370 mm centres must be fixed to the rafters or trusses over the underlay using fasteners to comply with Tables 10.1.5.A, B and

N.B. Battens at different centres may require different values.

15.3.1.5A Batten Installation

- Battens must have square cut ends and must be butt jointed over the centre line of the rafter.
- Adjacent rows of battens must not be joined on the same rafter and must span at least three rafter spacings at the roof edge.
- A batten must be installed immediately behind the fascia as fixing for the eaves tiles.
- Eaves tiles must overhang the gutter by a minimum of 30 mm.

Eaves tiles are recommended to overhang the gutter by 40 mm.

Because an eaves-tile batten is installed immediately behind the fascia the position of the next batten up the rafter will be less than that of the normal tile batten spacing. The position of this batten may vary depending on the pitch of the roof.

The edge of the roof should be taken as 20% of the roof width measured from the fascia, barge, hip or ridgeline, and will apply all around the periphery of each roof plane.

The batten layout is marked on the rafters by placing nails at the line of the batten fronts. The roofing underlay is laid over this, onto the rafters. The battens are then laid from the lowest part of the roof upwards, using the marker nails to locate the front edge of the batten. The marker nails are removed before the tiles are laid.

15.3.1.5.1 **Pullout resistance for different constructions**

15.3.1.5.1A Pullout resistance in kN required for battens for buildings with ceilings

cpe = -0.9, cpi = 0, cp = 0.9

Purlin/ batten size	Max Wind span	Wind	Wind	Wind	Wind	Wind	Wind	Wind
		Zone	Zone	Zone	Zone	Zone	Zone	Zone
		0.61kPa	0.61kPa	0.82kPa	0.82kPa	1.16kPa	1.16kPa	1.50kPa
mm x mm	mm	Low	Low	Medium	Medium	high	high	Very high
		32m/s	32m/s	37m/s	37m/s	44m/s	44m/s	50m/s
		M	P	M	P	M	P	M
50 x 40	900	0.2	0.3	0.3	0.4	0.3	0.5	0.5
50 x 50	1200	0.2	0.4	0.3	0.5	0.5	0.7	0.6

M = main body of the roof P = periphery

15.3.1.5.1B Pullout resistance in kN required for buildings without ceilings (but with a permeable windward wall)

cpe = -0.9, cpi = 0.2, cp = 1.1

Purlin/ batten size	Max Wind span	Wind	Wind	Wind	Wind	Wind	Wind	Wind
		Zone	Zone	Zone	Zone	Zone	Zone	Zone
		0.61kPa	0.61kPa	0.82kPa	0.82kPa	1.16kPa	1.16kPa	1.50kPa
mm x mm	mm	Low	Low	Medium	Medium	high	high	Very high
		32m/s	32m/s	37m/s	37m/s	44m/s	44m/s	50m/s
		M	P	M	P	M	P	M
50 x 40	900	0.2	0.3	0.3	0.5	0.4	0.6	0.6

M = main body of the roof P = periphery

15.3.1.5.1C Pullout resistance in kN required for buildings without ceilings (and with a dominant windward opening)

$c_{pe} = -0.9$, $c_{pi} = 0.8$, $c_p = 1.7$

Purlin/ batten size mm x mm	Max Wind spanZone 0.61kPa Low 32m/s	Wind Zone 0.61kPa Low 32m/s	Wind Zone 0.82kPa Medium 37m/s	Wind Zone 0.82kPa Medium 37m/s	Wind Zone 1.16kPa high 44m/s	Wind Zone 1.16kPa high 44m/s	Wind Zone 1.50kPa Very high 50m/s	Wind Zone 1.50kPa Very high 50m/s	
	M	P	M	P	M	P	M	P	
50 x 40	900	0.4	0.5	0.5	0.7	0.7	1	0.9	1.3
50 x 50	1200	0.5	0.7	0.6	0.9	0.9	1.3	1.1	1.7

M = main body of the roof P = periphery

15.3.1.5.1D Tile Batten Fastener Requirements

Fastener	Size	No.	kN
Gun nail	90 x 3.15	1	0.4
Ringshank nail (gun/hand)	90 x 3.2	1	0.6
Gun nail	90 x 3.15	2	0.7
Twist Shank Nail	90 x 3.3	1	0.9
Purlin Screw c/s head	10g x 100	1	2.5
Type 17 screw	14g x 100	1	7.3

15.3.2 Valleys

Valley gutters must be made of the same metal or coating as the roof tiles or a compatible material, and when the roof tile is painted or coated the valleys must also be painted.

Where secret gutters are used or where the flashings are unseen, they must have a durability of 50 years.

The valley must have a minimum upstand of 20 mm, and the fasteners must not penetrate the valley.

For valley sizing, see [5.5.7 Valley Capacity Calculator](#).

15.3.3 Roof Traffic

Metal Tiles are classified as a Type B roof cladding as they cannot be walked on indiscriminately without the risk of damage.

Persons authorised to walk on a metal tile roof must walk only in the pan of the tile where the batten supports it, and wear flat, soft-soled shoes to prevent damage to the tiles and surface coatings.

Other trades must be made aware by the contractor or site supervisor of the method of walking on pressed metal tiles without causing damage, and that the cost of repairing damaged tiles is their responsibility.

15.3.4 Valley Installation

See [E Metal Tile Valley](#)

The valley boards installed between the valley jack rafters to support the valley and tile battens are required to be set with their outer edge at a minimum of 90 mm from the centre line of the valley. Valley boards are required to support a point load of 1.1.kN, which is taken to be the weight of a tradesperson with a bag of tools.

Valleys are installed so water discharges over the back and into the eaves gutter. The valleys are held in position by clips specially designed to allow for expansion, or by compatible nails and washers placed alongside the valley or bent over the top lip of the valley.

Under no circumstances must the fasteners penetrate the valley surface.

Joints cannot have an overlap of less than 200 mm.

The top end of the valley should be turned up against the hip or ridge battens to the height of the batten. Where two valleys meet over a dormer, they are cut, shaped, joined, and sealed so that they form a continuous valley.

The tile edge should be bent down to a minimum of 5 mm from the valley floor.

The gap between tiles on opposing sides of the valley must be a minimum of 70 mm.

Valley boards and boards supporting flashings must be H.3 treated, and all metal and timber should be separated by underlay .

15.3.5 Flashings

Standard flashings are supplied for most locations on a roof, and are in two styles, only one of which is used on any one roof. All flashings and roofing accessories are made of the same base metal as the tiles.

- *Long accessories are 2 m long with fixing holes every 500 mm and there are specific accessories for ridges, hips, barges, aprons and walls.*
- *Short accessories are 400 mm long trims and can be used for most flashing applications on a roof.*

Special flashings are made as required by the manufacturer or the roofer from uncoated steel, and subsequently factory coated using the same coating process as used for tiles.

15.3.5.1 Ridge

Tiles must be turned up to a minimum of 40 mm against the battens, hip board or where they butt against a vertical or an inclined surface.

The ridge trim cap or side flashings must cover the tile turn-ups by a minimum of 35 mm.

Ridge tiles are bent up and then cut to form a turn-up that fits under the ridge/hip cap or short accessory. To ensure a watertight joint, a tight fit is required between the tile and the ridge cap.

15.3.5.1A Ridge and Hip: Short Trim Installation

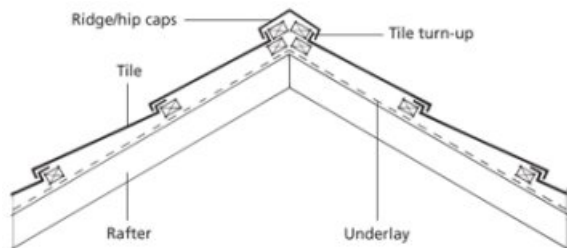

15.3.5.1B Ridge and Hip: Long Trim Installation

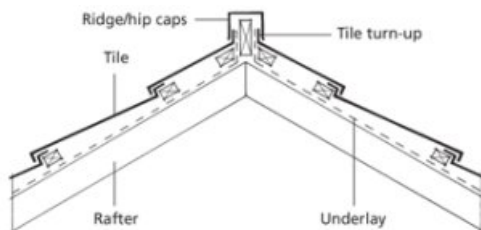

15.3.5.2 Hip

Tiles should be turned up against the battens or hip board by a minimum of 40 mm. See [15.3.5.1A Ridge and Hip: Short Trim Installation](#) and [15.3.5.1B Ridge and Hip: Long Trim Installation](#).

15.3.5.3 Gable Ends

Tile ends are turned up a minimum of 40 mm and installed against a batten that will be covered by a barge cover or under a metal fascia. If a hidden gutter is used, tile edges should be turned down into the gutter by a minimum of 20 mm.

15.3.5.3A Tile Turn-up

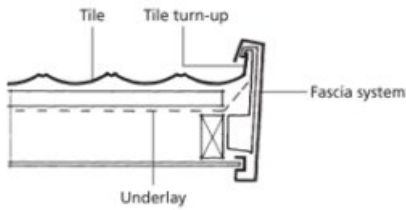

15.3.5.3B Trim/Barge Cover

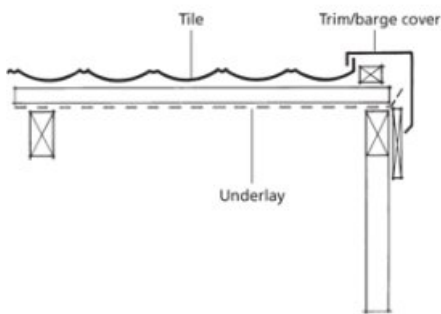

15.3.5.3C Barrel Trim

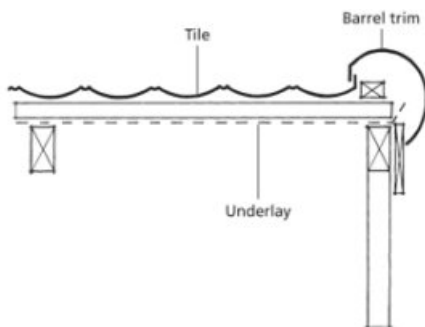

15.3.5.4 Flashing Metal Tile to Wall

The wall cladding flashings must be positioned before the tiles and must be designed so that the turned up tile can be inserted behind the flashing.

All preparatory work of under-flashing, fixing of eaves, gutters and valley gutters must be completed, and all tiling battens must be in place before laying tiles.

15.3.5.4A Metal Tile to Wall

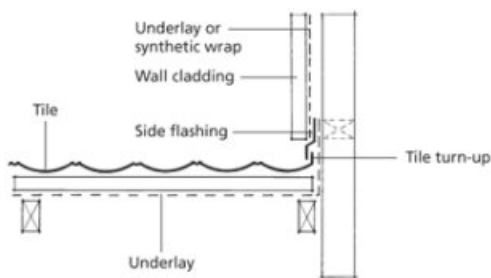

15.3.5.4B Pitched Metal Tile to Wall

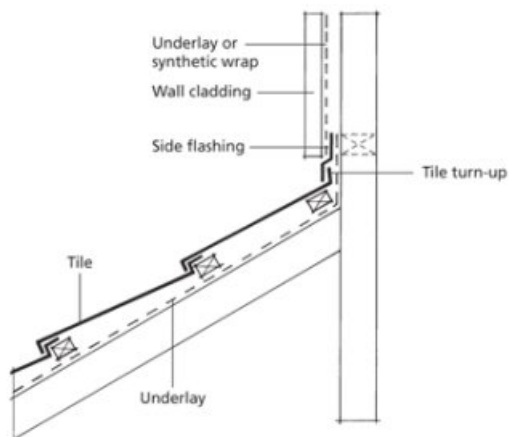

15.3.5.5

Wall To Roof Junctions

Flashings at the ends of roofs, where the roof does not end past the wall require a stop-end flashing that ensures water is directed into the gutter. Sufficient material should be left standing out from the wall so that cladding installers can ensure a weatherproof finish.

15.3.5.5A

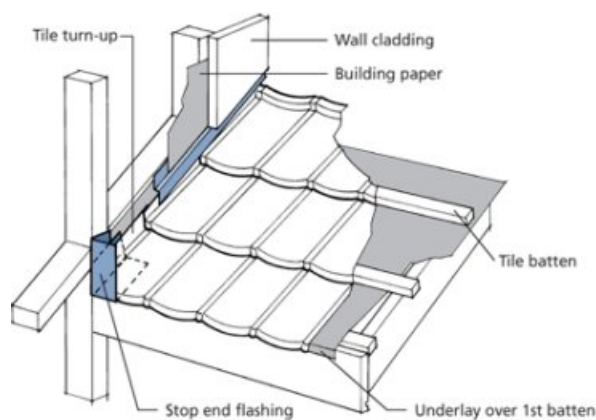

15.3.5.6

Penetrations

Tiles cut for penetrations through the roof should be provided with up-stands and over-flashed for drainage from above without restricting the water flow.

The flashing should finish 15 mm beyond the tile head lap above the penetration and should be wide enough to cover the nearest tile rib or up-stand. When the construction is solid masonry or brickwork, and flashings cannot be installed under the wall cladding, a chase should be cut and an over-flashing installed in the chase to provide weather protection.

15.3.6

Longrun Tiles

A long-run tile is a hybrid roof cladding providing the appearance of pressed metal tile with the fixing attributes of long-run profiled metal cladding.

The minimum pitch is 8°, and underlay and battens are fixed in the same manner as for pressed metal tiles.

The module or step size of the profile can be adjusted, and the pitch of the tile can be varied to suit any batten spacing on an existing roof or to alter the roof appearance.

Maximum sheet length is 7 m however transverse laps are possible.

The material is pre-painted metallic coated steel with a yield strength of G250 Mpa. It is fixed with nails or screws at the front of the tile.

Sheets should be back-laid, working from right to left which prevents creep at the gutter line due to the back-step in the underlap of the profile.

Longrun tile can be curved to a 250 mm radius.

15.3.6A Long-run Metal Tiles

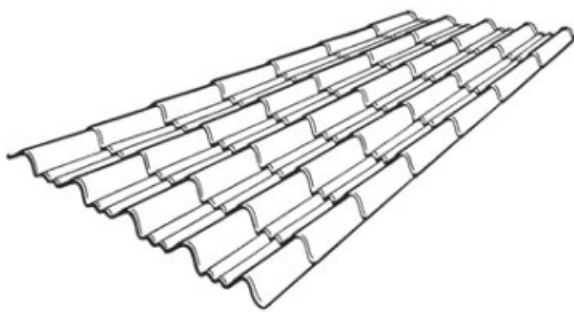

15.3.7 Sitework

The requirements of [13 Site Practice](#) also apply to the installation of metal tiles. In addition all gutters, valleys, roof channels and the roof should be left clean and free from debris on completion of the work.

15.3.8 Laying Metal Tiles

The roofing supervisor will establish when the roof should be installed after all sub-trade work has been completed.

All preparatory work of under-flashing, fixing of eaves, gutters and valley gutters must be completed, and all tiling battens must be in place before laying tiles.

If substantial work, such as texturing walls, is to be carried out on a wall above or adjacent to where metal tiles are to be laid, they should be installed after such work has been completed.

Tiles should be inspected and selected, as tiles of a different colour match should not be installed on the same plane of a roof. If more than one pallet of tiles is required for one job, the colour uniformity should be checked.

Tiles damaged during installation must be removed and replaced, and any deformed tiles or tiles with

surface damage must be rejected.

Tiles should be laid from the ridge down to avoid unnecessary traffic and can be laid broken bond or straight down the roof.

The eave gutter tiles should project over the edge of the fascia to ensure that water discharges directly into the gutter system and tiles should be laid so they prevent any water penetrating into the roof cavity.

Before tiles are laid, the direction of lay should be determined by:

- Taking into account whether the profile can be laid only one way or both ways;
- Appearance, so that laps face away from the line of sight;
- Allowing for prevailing weather exposure.

Installation of perimeter tiles (excluding eaves tiles) can be completed before the main body of tiles are laid.

15.3.9 Workmanship

Graphite pencils must not be used to mark AZ coated steel products as carbon can cause premature corrosion failure of the coating.

Finishing of tile cuts and bends must leave straight lines up the roof section, to provide a true line for flashings.

When cutting tiles for their installation at ridges, hips, valleys and barges, avoid damage to the surface finish by using a guillotine or metal shears. When cutting the tile lengthwise, it must be bent before cutting to reduce the amount of distortion that occurs as the profile is flattened during bending.

Tiles turned up and down for ridges, hips, valleys and barges must be bent using a bender specifically designed for this purpose. Tiles must be turned up at ridges, hips and barges by a minimum of 40 mm, and down into the valleys to a minimum of 5 mm from the valley floor.

15.4 Tray Roofing

Standing Seam or Tray roofing is similar to trough section in that it is secret fixed, but it consists of just a single pan per sheet, compared to the two or three pans of a trough section.

The profiles and fixing methods for tray roofing date back to traditional methods used to hand-fabricate metal roofs, predominantly in Europe and often from non-ferrous metal, prior to the development of roll forming technology. A by-product of this heritage is that, in addition to the secret clips fastening the main roof, flashings should also be installed on clips with minimal use of exposed rivets and fasteners.

In Europe, the installation of tray roofing is done by Spenglers, who serve a 4-year apprenticeship. We do not have the same qualification in NZ, but installers of tray roofing must have specific training and experience in the product if they are to achieve the expected high standard of workmanship

15.4.1 Tray Profile Materials

Traditionally tray roofs were manufactured from sheets of copper or pure zinc (sometimes even lead) and these materials are still popular being naturally durable and weathering to a natural patina. They are also very malleable which allows more variation in intersections and terminations, and they can be soldered.

More common in the New Zealand market are pre-painted steel and aluminium substrates. To increase its formability, Steel is normally supplied in Medium Strength G300 grade and Aluminium in hardness grade H34.

See [4.16 Materials](#) for a more thorough discussion of roofing material.

15.4.2 Standing Seam Profiles

Self-support profiles resemble a single tray trough section but the ribs are generally narrower and the installation techniques more sophisticated. Pan widths for both types vary from 300 mm to 500 mm.

Self-support tray profiles may be machine run and have female and male side laps that clip together.

15.4.2A Typical Self-Supporting Profile



Standing Seam profiles are a subset of tray roofing. They are laid on solid sarking and may be formed by machine or folding, and installed by traditional methods using hand tools to lock sheets together at side laps.

Traditional shapes are angle seamed, double seamed, or roll cap. The angle seam is the most popular and the double seam is the least popular. The roll cap replicates old roofs with a capped joint installed over a longitudinal batten.

One of the features of standing seam roofs is that they can be formed by folding rather than roll-forming. This

15.4.2B Angle Seam

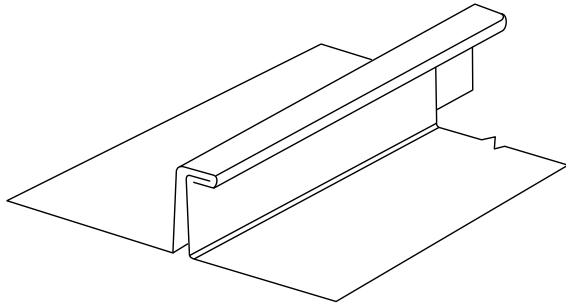

15.4.2C Double Seam

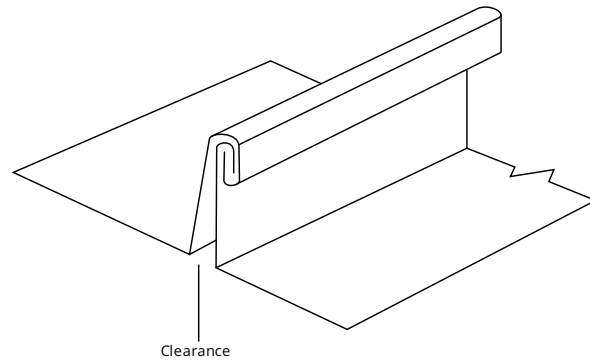

15.4.2D Standing Seam Roll Cap

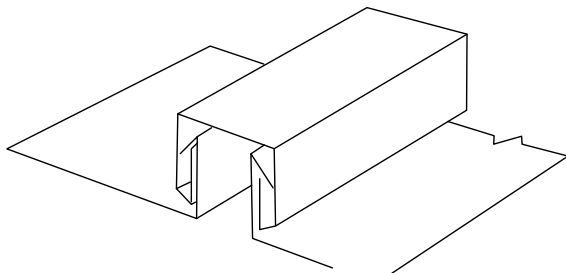

makes it possible to install roofs to buildings that are round or sinusoidal in plan, to have “random” pan widths, or to vary rib width discretely so that ribs are spaced equidistant from associated architectural features such as penetrations and windows.

All tray roofing must have clearance between adjacent pans to allow for timber shrinkage and transverse thermal expansion of the pan. The non-existence of this clearance gap can cause excessive canning or quilting.

15.4.2E Standing Seam Cladding on a Sinusoidal Building Plan



15.4.2F Standing Seam Cladding on a Round Building.



Source: UK Guide to Good Practice in Fully Supported Metal Roofing and Cladding 3rd Edition; © Federation of Traditional Metal Roofing Contractors

Source: Scope 54, p. 31; © NZMRM

Some manufacturers have the facility to curve their trays in a concave or convex shape.

15.4.3 Standing Seam Design

Tray and particularly standing seam profiles lend themselves to many variations in installation details. Installers are generally specialist and highly trained and may modify or improvise a detail to suit the particular needs of a situation. Because of this, the demarcation between design and installation is not clear cut.

The following information on design and installation is generally applicable to all tray roofing including self-support, apart from the sections on sarking and load tables. Sections particular to standing seam are headed as such, but there is a large amount of cross-over in many areas.

Standing seam products are generic and the load tables included are specific to them. For proprietary tray roofs, load tables should be provided by the manufacturer.

15.4.3A Roof-Wall Junction Without Needing Prickles



All tray roofs can be seamed at the junction of roof and wall, without the need for prickles.

15.4.4 Tray Fixings

Perhaps the most outstanding feature of all tray roofs is the minimisation of visible fasteners. Apart from the secret fixing clips, attachment of flashings to the roof should be achieved by crimping to the roof or to a grab flashing wherever possible.

Clips for standing seam roofing are normally single clips, fastened to the substrate with screws or annular grooved nails. The sole of the screw should have a rebated or countersunk hole for the fastener, and rounded edges, to ensure thermal movement of the sheet does not cause damage by rubbing against sharp edges.

Wall cladding laid horizontally may need additional support, in addition to the standard bracket, to resist gravity loads.

15.4.5 Standing Seam End Laps

As the style of roofing replicates hand-formed products of yesteryear, and because the sheets themselves are relatively flexible, end laps are more common in tray roofs, and more acceptable, than with other profiles. In practice, staggered end laps are often used with tray roofing as an architectural design feature.

15.4.5A Staggered End Laps



Source: UK Guide to Good Practice in Fully Supported Metal Roofing and Cladding 3rd Edition, © Federation of Traditional Metal Roofing Contractors

15.4.6 Sarking

Sarking is commonly CPD (Construction Panel Directive), Stress grade 11, 15 mm ply laid on supports at 800 centres, or 17 mm ply at 900 centres. Ply should be laid with face grain at a right angle to supports. Edges of sheets not held by plastic tongue or T&G should be supported. Fasteners should not be closer than 10 mm from sheet edges.

15.4.6A Ply Sarking Fixing Pattern

Wind Zone	Edges fix at 75 mm centres	Body fix at 150 mm centres
Up to High Wind Zone	60 x 2.8 nails or 8g x 40 mm screws	60 x 2.8 nails or 8g x 40 mm screws.
Very High and Extra High	75 x 3.15 nails or 10g x 40 mm screws	75 x 3.15 nails or 10g x 40 mm screws

To allow for expansion, maintain 3mm gap between sheets. At gutter line the ply should overhang the gutter line by 25 mm and remain square cut. Dormer valleys and valleys into spouting can be recessed or flat laid.

15.4.7

Tray Ventilation

Because of their relatively narrow ribs, tray roofing generally self ventilates less than other roof profiles. This puts more responsibility on the designer to consider ventilation of the ceiling space. Ventilation is particularly important for fully supported profiles; the ply must have a gap at the apex to allow for egress of air and a gap at the bottom, or soffit vents, to allow air ingress.

15.4.7A Standing Seam Ventilation

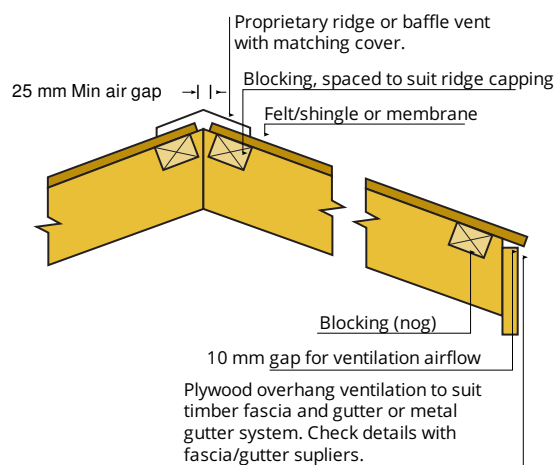

15.4.8 Standing Seam Roofing Wind Loads

Clip spacings for proprietary tray roofing must be set out as per the manufacturer's data for the design wind load of the building.

15.4.8A Generic Standing Seam Clip Spacing

Rib Height	Max Pan Width	NZS 3604 Wind Zone			
		Medium	High	Very High	Extra High
25 mm	300 mm	500 mm	500 mm	500 mm	500 mm
	400 mm	500 mm	500 mm	500 mm	500 mm
	500 mm	400 mm	400 mm	400 mm	N/A
32 mm	300 mm	600 mm	600 mm	600 mm	600 mm
	400 mm	600 mm	600 mm	600 mm	600 mm
	520 mm	600 mm	600 mm	600 mm	400 mm
38 mm	300 mm	600 mm	600 mm	600 mm	600 mm
	400 mm	600 mm	600 mm	600 mm	600 mm
	500 mm	600 mm	600 mm	600 mm	400 mm

15.4.8.1 Tray Roofing Wind Noise

Wind-induced noise can also be an issue in high-wind areas with winds above 20m/s. It can be minimised by specifying a narrower pan width and closing clip centres. Further noise reduction can be gained by putting a concave shape into the pan, which can be achieved by:

- installing longitudinal stringers (e.g., a 10 mm batten) under the centre of the tray or
- installing strips of compressive material along the purlins.

Geotextile mat layers have the most significant effect on noise attenuation, but the added cost of such should be weighed against the expected benefits

15.4.9 Penetrations on Tray Roofing

The wide flat pan of tray roofing makes it easy to achieve secure penetration details. Proprietary rubber boot flashings can be used for small pipe penetrations, but a more aesthetically pleasing solution is to make up a flanged upstand in pre-painted steel or colour matched malleable metal, and fit a "Chinese hat" to the penetration to allow for thermal movement and weatherproofing.

15.4.9A Penetrations on Standing Seam Cladding



15.4.9B Avoiding Long Back Trays



Avoiding the use of long back trays helps achieve an aesthetically attractive solution for penetrations

15.4.10 Tray Roof Flashing

Install grab flashings at verges, hips and ridges, and to wall cladding intersections, to minimise exposed rivets and fasteners.

15.4.10A Tray Barge Flashing

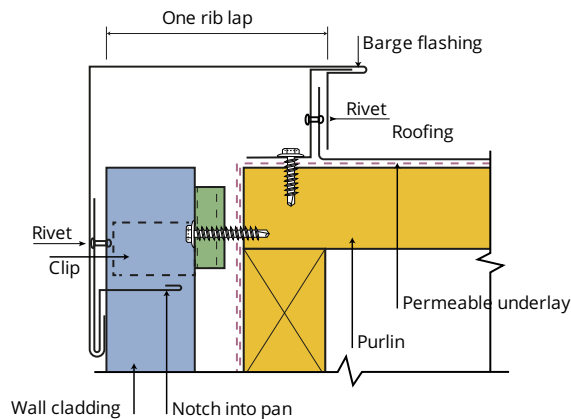

15.4.10B Tray Transverse Apron

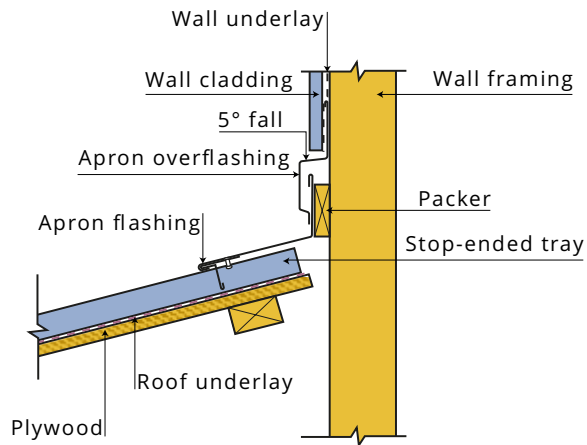

15.4.10C Tray Valley

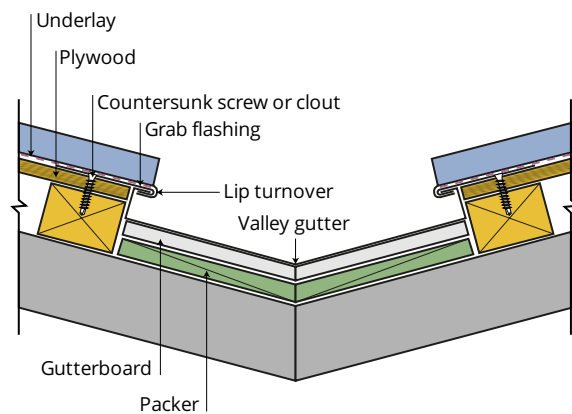

15.4.10D Tray Window Head

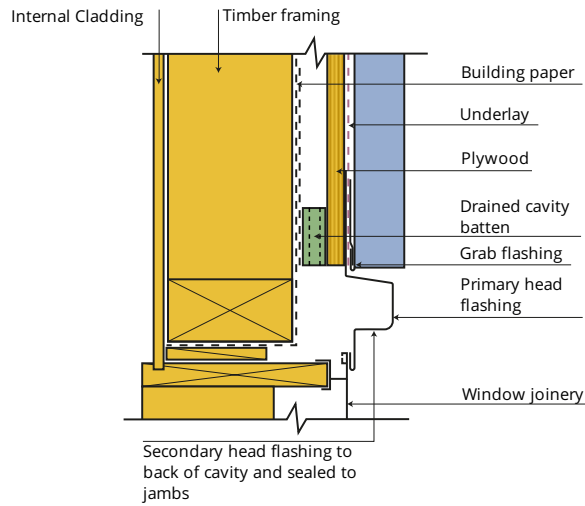

15.4.10E Tray Window Jamb

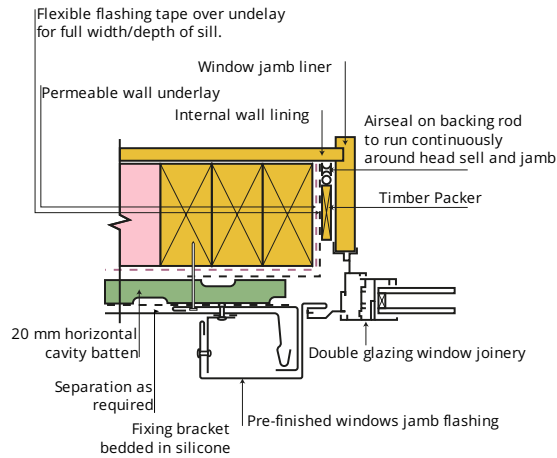

15.4.10F Tray Window Sill

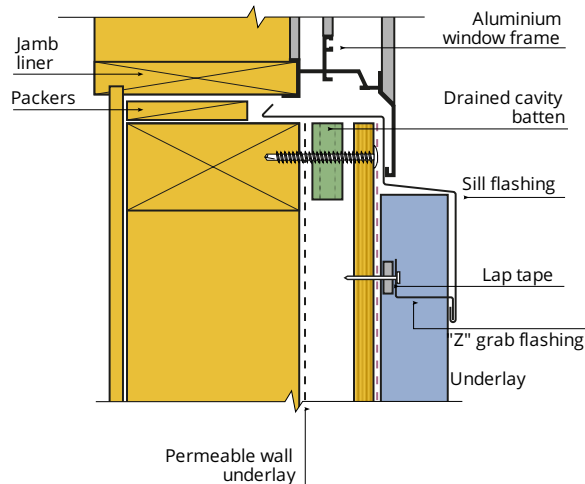

15.4.11 Canning and Purlin Creasing

Oil canning, panning, or quilting, is the term used to describe visible waviness of the pan of a metal roof.

Oil canning is one of the most controversial aspects of tray roofing. Some people accept it as an innate feature of a tray product, others want a flat tray with no visible waviness. It may not be obvious, but it is always present in tray roofing to some extent. The visibility of canning is affected as much by the lighting, line of sight, cleanliness, and gloss levels of the roof, as it is by the degree of canning present in the product.

Clients expecting no canning should be informed of the reality, particularly if the roof runs at an acute angle to one's line of sight. Canning can also be induced by stretching the material or excessive foot traffic. The substrate must be true to plane and not convex.

The most effective ways to minimise canning in a highly visible situation is to use a profile with a narrower pan and use material with a low-gloss or textured surface.

With self-support tray roofs, excessive foot traffic will accentuate purlin lines, because of the ductility of the metal (grade G300) and the wide flat pan.

15.4.12 Installing Tray Cladding

Tray roofing is a predominantly flat, secret fixed profile with one tray per sheet and vertical ribs. The roofing sheets are clip-fastened, using hidden clips. Tray cladding which is installed on sarking by traditional methods with hand-formed side lap seams is known as standing seam cladding.

15.4.12.1

Standing Seam Cladding Set Out

With a wide tray profile, it is important to have matching distances from the adjacent rib to any major architectural details. Prior to commencing the lay, the roofer must determine what the predominant features are on a given face and set the roof out to maximise symmetry of side flashings and matching rib lines. With fully supported profiles, sheets can be folded to varying widths to achieve symmetry across a number of architectural features.

15.4.12.2

Commence Laying Tray Cladding

1. Install the eaves grab flashing to which the sheets will be crimped and any other flashings that may be behind the cladding, for example, window jamb flashings.
2. Fit the netting and/or underlay. On flat roofs requiring underlay support, using twine is preferable to netting as the joins in the latter may imprint through the medium strength iron through foot traffic.
3. Form stop-ends in the sheets.
4. Then the sheets can be laid, starting from a distance from the barge to give equal cover distance to the opposing barge and other architectural features and penetrations. Fasteners should be annular grooved nails or screws, with clips at centres specified by the manufacturer to suit the product and wind zone.

Pre-painted tray roofing will usually be supplied with strippable film to give temporary protection from scratching. The film should be removed from underlaps while laying, and removed entirely before UV sets the adhesive making it difficult to remove without leaving glue residue on the sheet. Traffic across sheets should be kept to a minimum, particularly with self-supporting products.

15.4.12.3

Provision for Expansion – Tray Roofing

Non-ferrous tray roofing expands at about twice the rate of ferrous metals. Supported angle seam and double seam profiles must be installed using a balance of sliding clips to allow for expansion, and fixed clips to withstand gravity loads.

The position of the fixed clips depends on the roof pitch. The width of the fixed clip portion should be sufficient to install five clips at the required spacing.

15.4.12.3A Clips Positioning for Non-Ferrous Profiles as Determined by Roof Pitch.

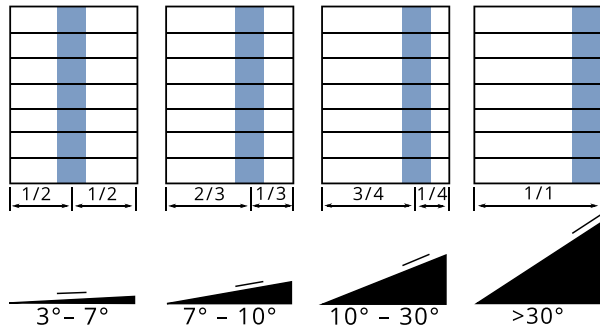

Steel based angle seam and double seam profiles up to four metres in length can be laid without sliding clips. Roll cap and self-support tray roofing have clip systems that can accommodate thermal movement, and also do not require special sliding clips.

15.4.12.3B Using Clipped Flashings Minimises the Need for Rivets



Using clipped flashings to minimise the use of rivets is a feature of a well-installed standing seam roof.

15.4.12.4

Finishing at Ridges and Eaves of Tray Roofing

Crimp sheet at ends to eaves flashing with eaves crimping tool, and cut and fold rib to close rib ends. Remove strip film, if applicable, and for standing seam roofs lock adjacent sheets together with rib purpose made closer tool.

15.5 Warm Roofs

Warm roofs are where insulation is in direct contact with the roof cladding. It can be divided into three main categories:

- insulated panels,
- composite or site assembled systems, and
- roofs with insulation sprayed on after [installation](#).

15.5.1 Insulated Panels

Insulated or sandwich panels are factory-made laminated products using different core materials permanently bonded by adhesive or foam to metal skins to act as a single structural element.

15.5.1.1 Insulated Panel Manufacturing

The manufacturing process for bonded panels consists of roll forming the flat or profiled sheeting, followed by the adhesion of the insulation core to both surfaces or skins.

There are three methods to do this:

- *Continuous production by injecting foaming insulation between 2 metal skins as they are being roll-formed.*
- *Continuous production by glueing pre-formed panels of insulation to roll-formed metal skins.*
- *Individual panel production by glueing insulated panels to roll-formed sheets*

Bonded composite panels develop their strength from the sandwich of skins and insulation, and are made with a tongue and groove side lap detail that incorporates concealed fasteners.

15.5.1.2 Insulated Panel Composition

The structure and composition of an insulated panel are chiefly determined by its end use.

15.5.1.3 Insulated Panel Face Profiles

Three types of profiles are used on insulated panels. This is largely determined by the spanning requirements and ease of maintenance.

15.5.1.3A Flat Metal Panels (predominantly used for walls and cool rooms)

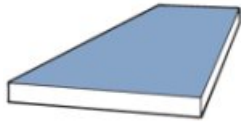

15.5.1.3B Profiled Metal Panels (predominantly used for roofing)

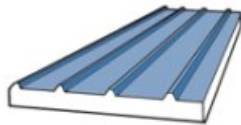

15.5.1.3C Miniature Ribbed Panels (predominantly used for walls)

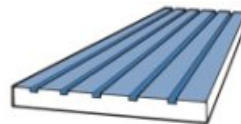

Flat continuously produced panels suffer minor undulations in the metal skins that arise from built-in tensions in the metal coil and are introduced during panel manufacture. Panning can be minimised by using a matt finish or forming minor ribs or swages on the flat face of the panel.

15.5.1.4 Insulated Panel Face Materials

The facings or skins of composite panels are typically metallic coated, pre-painted steel or aluminium, and are either profiled or flat on either or both sides of the panel. The internal skin is also known as the liner skin or sheeting.

The metal facing is commonly made from grade G300 steel of 0.40 – 0.63 BMT thickness, with a pre-painted organic finish over a metallic coating. Cool room panels have a galvanised Z275 metallic coating, while interior/exterior structural insulated panels have an aluminium/zinc coating of AZ150 or AZ200. Paint coatings are specifically developed to assist in bonding the insulation to the panel

Aluminium facings are used in very humid conditions or severe marine environments and can be supplied plain or pre-painted.

15.5.1.5 Insulated Panel Core Materials

The core can be made from different types of material with different insulating values, fire ratings, and strengths. The most common are EPS (Expanded Polystyrene), PPS (Phenolic/Polystyrene), PIR

(Polyisocyanurate), and mineral fibre.

EPS

EPS foam is mainly used for applications where high fire resistance is not a requirement.

PPS

PPS may be used where greater fire resistance is required.

PIR

PIR foam is increasingly specified because of its fire-resistant properties and better insulation efficiency.

Mineral Fibre

Mineral-fibre insulation may be selected for applications where fire resistance and/or acoustic insulation properties are of prime importance.

15.5.1.6

Insulation Panel Insulation Values

The insulation thickness of a profiled roof panel varies from 30 mm to 300 mm. To achieve the same insulating value as a flat panel, a profiled roof panel needs to be thicker. The through fasteners or fixing clips are thermal bridges, but it has been shown that these are unlikely to decrease the R-value by more than 2%.

Different cores will also have different values for thermal insulation and noise attenuation, as will the details of panel joints and interfaces with other materials.

The nett insulation value of a panel must be calculated and stated by the manufacturer.

Since we say it won't increase by more than...we can stay with the top value.

R-values are the reciprocal of U-values. We will stick with R-value because that is the most commonly used value for roofs and walls.

15.5.1.7

Insulation Panel Structure

Insulated panels are integral units in which the insulation layer together with the two metal skins act as a beam to resist wind and point loads. The bonded insulation core material contributes to the panel's strength by effectively increasing the web depth of the profile and resisting buckling; the depth of the core largely determines the panel's resistance to deflection. Panel stiffness is also affected by skin thickness and profile shape.

Insulated panels are excellent at supporting normal foot traffic without damage because the foam core provides continuous support to the external sheeting. The number and strength of the fasteners under wind suction loads can limit the maximum purlin spacing.

15.5.1.8

Natural Lighting for Insulated Panels

Where roof lights are required, the maximum purlin spacing will be limited by the strength of the roof light sheeting; it can be extended by using mid-span supports. Polycarbonate or G.R.P. barrel vault roof lighting may be

used for greater spans or proprietary systems may be supplied by the manufacturer.

15.5.1.9 Insulated Panel Acoustics

Insulated panels do not have inherently good acoustic insulation properties. Sound can be lessened by using sealed joints, but where higher levels of acoustic attenuation or absorption are required, it may be necessary to install additional acoustic lining [systems](#).

15.5.1.10 Insulated Panels and Internal Moisture

Metal facings are effectively impervious to penetration by vapour, and panel cores have a closed cell structure which does not permit significant transmission or absorption of vapour. However, to prevent the possibility of interstitial condensation, it is necessary to fasten and seal all laps and gaps, side-lap joints, transverse laps, and joints and ridges that are exposed to the internal environment.

When insulated panels are used as cold store insulation, a complete and continuous vapour barrier is essential to prevent inward moisture vapour pressure. Any discontinuity will result in a build-up of ice which can destroy the panel.

The bottom skins of composite panels have an integral side lap with a re-entrant sealing space which acts as a vapour control, but in high-risk applications such as food processing buildings, textile mills, and indoor swimming pools an additional sealer strip is required in the side lap joint.

15.5.1.11 Insulated Panels Fitness for Purpose

Thermal bowing can occur when the two skins are at significantly different temperatures such as north-facing walls, e.g., when a cool room roof panel is in direct sunshine. The effect is accentuated when the external surface is a dark colour and is more severe for aluminium facings.

15.5.1.12 Insulated Panel Installation

The use of insulated panels for roof and wall cladding requires the same or similar detailing for Structure, Durability, External Moisture, and other design considerations as those for single-skin roof and wall cladding.

15.5.1.13 Insulated Panel Installation Safety

In most applications insulated panels can be installed by workers operating off the already installed sheet, negating the need for safety mesh. Many panels are installed using underslung safety nets. Other than that, all safety precautions should be followed as for any other cladding material.

15.5.1.14

Insulated Panels Supporting Structure

Due to their inherent stiffness, insulated panels do not have the flexibility to follow uneven structures. Insulated panels are supported on purlins or girts, which should be accurately erected to a maximum tolerance of 3 mm and a deflection limit of $l/600$.

15.5.1.15

Insulated Panel Penetrations

Insulated panels can accommodate penetration openings of 350 mm diameter or 300 mm square without the need for additional structural supports or trimmers. Where larger holes are required, trimmers should be in place before the erection of the panels.

15.5.1.16

Fixing Insulated Panels

Purpose-designed high thread-type fasteners are required to spread upwards loads and maintain the weather seal between the metal skin and the washer. Through fixings for roof panels may be rib fixed or located on a mini-rib within the trough, and should be set snugly to achieve a weatherproof seal without distorting the rib profile. Care must be taken not to over-drive the fasteners as this can cause damage to the G300 outer skin of the panel which can result in water ingress issues

Insulated roof panels with trapezoidal ribs are through-fixed with a load spreading washer on the rib and require lap fixing and sealing at the side laps to the manufacturer's recommendations.

15.5.1.17

Insulated Panel End Laps

The maximum practical length of panels for transport and handling efficiency is restricted to approximately 25 m. Where a transverse joint is required, there are two options:

- Butt End Lap
- Waterfall Junction

Butt End Lap

The lining and insulation are butt-jointed over the purlin, and a 150 mm overlap of the top sheet is formed in the external weather skin only, using three or more lines of sealant and fasteners. The sealant should be butyl tape, silicone or MS sealant, or self-adhesive closed cell tape according to the specifications of the manufacturer and should be positioned at the top and bottom of the lap. To provide a secure seal with flat or wide pan profiles, additional sealed rivets or stitching screws are required through the top skins only.

The challenge with this detail is that there are four layers of material to consider at the side/end junction. While successful in many instances, problems developing later are very difficult to remedy.

Waterfall Junction

A waterfall step can be achieved [by putting a step in the rafter](#) or [by increasing purlin cleat heights](#),

The first challenge of this detail is that the cold skin of the upper sheet cannot rest on the upper surface of the

lower sheet, so a thermal break must be created. The second challenge is that any gap between the upper and lower sheets must be adequately insulated to ensure that the thermal efficiency of the system is not compromised.

15.5.1.18 Insulated Panel Flashings

Flashings detailing is similar to that used with single-skin roof and wall cladding. The main exception is that internal joints should be designed and sealed so that water vapour cannot impregnate the system.

The panels at the ridge and other edges of the roof should be sealed and the lining closed with a metal trim mounted on the ridge purlins as detailed by the manufacturer. Any gap between the ends of the composite panels should be insulated to eliminate cold spots or cold bridging. They can be sealed using in-situ injected foam or mineral fibre. In high-humidity applications, the liner trim should be sealed to the panels. At end-laps or gaps, foam should be injected to provide a vapour-tight seal.

Where required by the manufacturer, eaves panels should have the ends turned down to prevent capillary action on the underside of the sheet. A metal flashing may also be installed to cover the exposed end of the insulation and metal liner when panel ends are visually exposed.

15.5.1.18A Insulated Panels Ridge Detail

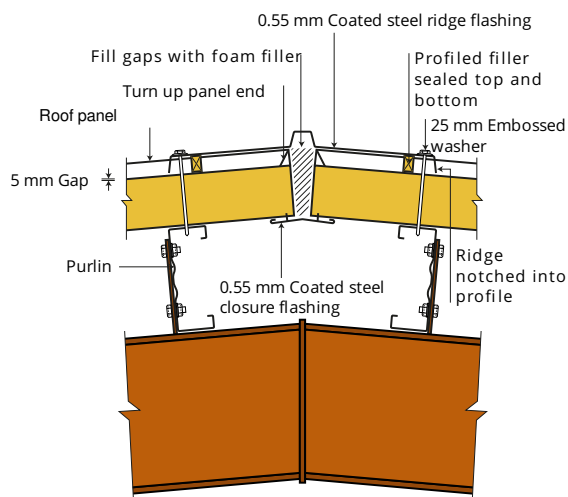

15.5.1.18B Insulated Panels Barge Flashing

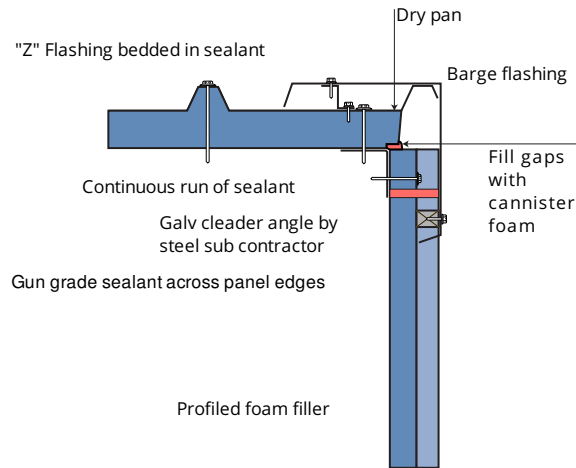

15.5.1.18C Insulated Panels Eaves Detail

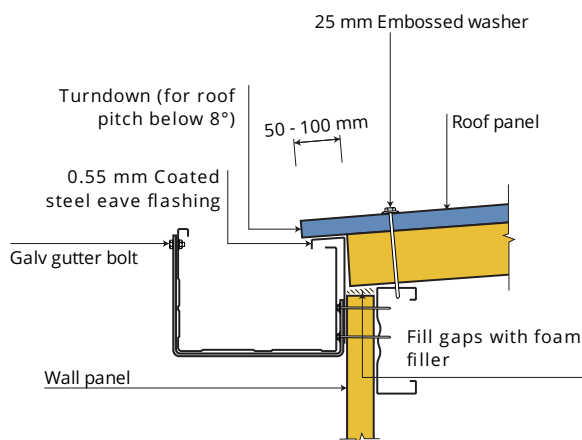

15.5.1.18D Insulated Panels Lap Join

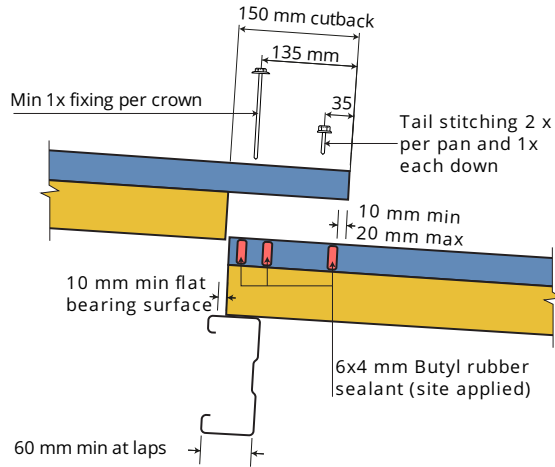

15.5.1.18E Insulated Panels step join

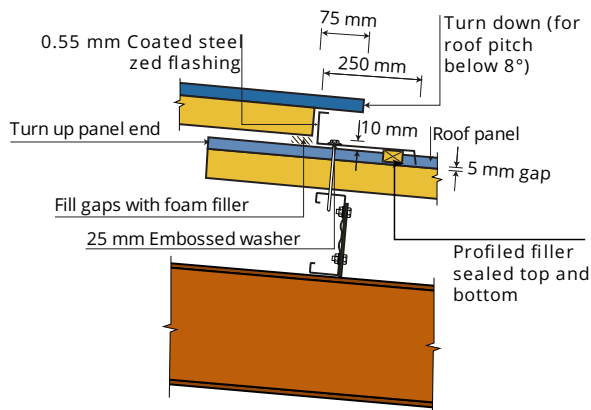

15.5.1.18F Insulated Panel Parapet with Transverse Apron

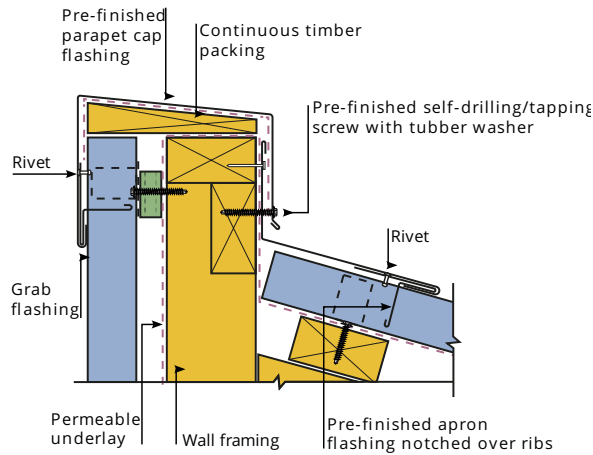

15.5.2 Composite Systems

Site-assembled or built-up warm roof systems are also known as composite systems. They are not a true warm roof, as the ribs are typically not in contact with the insulation, but they have many of the same attributes as warm roofs.

The advantages of composite systems are that they offer longer runs without the need for roof laps or waterfall junctions, and when the time comes for the replacement of the outer weather-proofing roof sheet, the system allows for it to be done without disturbance to the operations within the building.

Acoustic boards can be laid within the system to increase sound absorption either from within the building or from outside. Installation of the under-liner sheets can make a building largely watertight allowing other trades to continue below while the roof is completed.

15.5.2.1 Composite Systems Composition

There are three main types.

- Bespoke systems that incorporate layers of material and insulation above the purlin.
- Proprietary systems that are built up by layer above the purlin, such systems can be sandwich-type or post and rail.
- Overlay systems that are used for re-roofs over existing roofing.

Composite systems typically incorporate a sealed vapour control layer under the insulating layer, and an absorbent roofing underlay under the top skin. They may be designed as closed systems, or ventilation may be introduced between the insulation and the top surface. The insulation material may be expanded foam, mineral wool, or fibreglass blanket. Top surfaces may be profiled metal or membrane.

Post and rail systems allow thicker insulation to be used, increasing thermal and fire performance.

15.5.2.2 Composite System Installation

Composite systems are normally laid layer by layer to form the desired system. Typically, they comprise a metal base layer to provide support for the insulation, which is overlaid by a vapour check layer, insulation, underlay, and the top roofing sheet.

Post and rail systems are often used for over-laying existing roofs in good, safe condition. Another form of overlay uses custom cut blocks as pan infills, over which is laid a continuous insulating layer. These forms of roof repair avoid the need for removal and replacement of an existing roof, allowing the building tenants' operations to continue uninterrupted.

When installing composite systems, it is important that the vapour control layer is correctly installed and sealed to manufacturers requirements, and insulation is laid correctly without gaps. Bulk insulation must be able to loft up to its design thickness to achieve the design R-value.

15.5.2.2A Typical Composite Roof Unvented

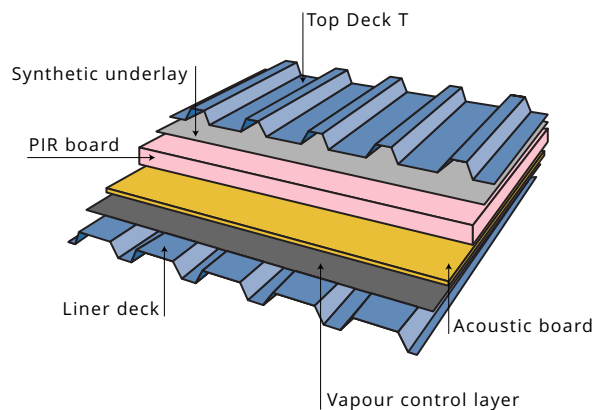

15.5.2.2B Typical Composite Roof Vented

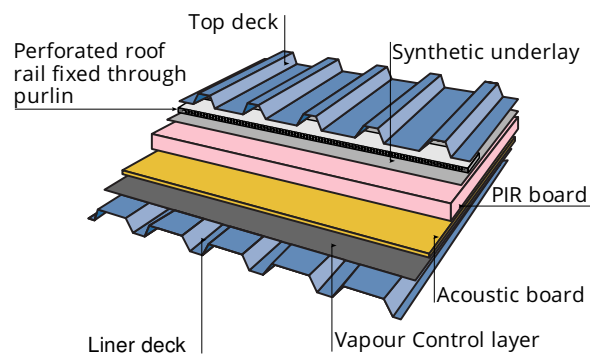

15.5.2.2C Typical Built-Up Roof

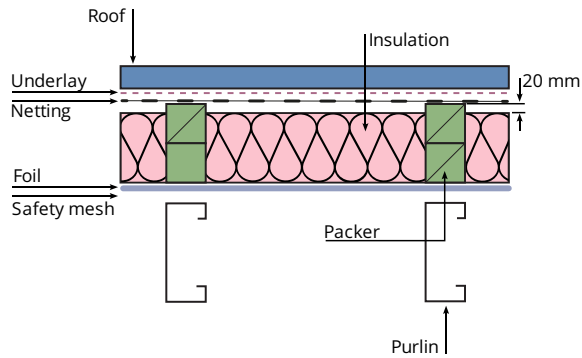

15.5.2.2D Post and Rail System

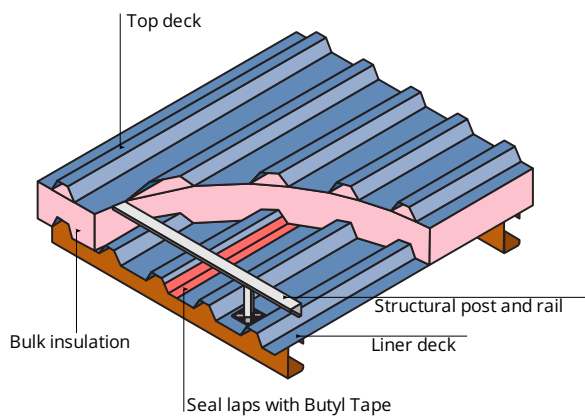

15.5.3 Spray-On Systems

Warm roofs can also be constructed by applying [spray](#) foam after installation.

Spray foam is typically polyurethane closed cell foam applied in thicknesses according to the insulation requirement. It can also be applied to walls, ceilings, and under floors. Spray foam may be applied to any roofing profile. It has a greater insulation value per millimetre than other insulation materials, so is particularly suitable for flat roofs and skillion roofs where there is limited air space.

Spray foam is non-absorbent (less than 1%) and has strong contact with all adjacent building elements. This makes it an effective vapour check, so internal moisture issues must be considered when using this or any other non-permeable system.

15.5.3.1

Ventilation of Spray-on Systems

When sprayed foam is applied directly to the underside of profiled metal sheet roofing on a lined building, the ceiling space must be adequately ventilated by other means. (See [10 Internal Moisture](#).)

Installation with underlay.

Polyurethane Spray foam may typically be applied directly to any type of purpose-made bituminous or synthetic building wrap, including foil-backed, excluding polyethylene sheet which is not a suitable substrate as there is inadequate adhesion.

The typical procedure for application is:

1. Check the building to confirm that the wrap is not loose or floppy, is properly attached to the studs, and is not sagging between purlins.
2. Spray a "flash-coat" of Polyurethane Spray Foam over the building wrap or cladding contacting the timber or metal framing. Allow to set – it will take 5-10 minutes depending on the ambient conditions. The "Flash-coat" will tension the building wrap, give it some rigidity, and assist with the curing and adhesion of subsequent layers.
3. Spray the first pass of Polyurethane Spray Foam onto the flash-coat. Do not exceed 25-30 mm with this pass. This will render the building wrap/foam composite rigid and able to take the balance of the foam with no distortion.
4. Spray the second pass of Polyurethane Spray Foam to the desired thickness to achieve the required R-value (or up to a maximum of 100mm per pass).

15.5.3.1A Spray-on Foam with Underlay

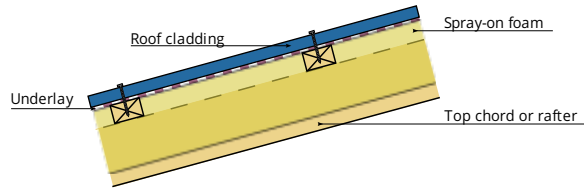

15.5.3.1B Spray-on Foam without Underlay

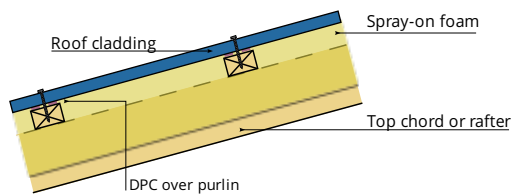

16

Maintenance

Maintenance is defined as 'to keep in good condition or repair', and can be divided into four categories:

- Reactive
- Scheduled
- Preventative, and
- Special

16.1 Maintenance Compliance

- Section B2.3.1 of the NZBC requires components to satisfy the requirements of the building code, for 50, 15, or 5 years (according to their categorisation) with only Normal Maintenance.
- B2/AS1 section 1.2.1 defines 'normal maintenance' as: "work that is generally recognised as being necessary to achieve durability for a given building element...."
- B2/AS1 Section 2.1 states that it is the responsibility of the person specifying the building element to determine Normal Maintenance requirements which may be based on the manufacturer's recommendations
- B2/AS1 section 2.1.3 gives examples of Normal Maintenance as:
 - a. Following the Manufacturer's maintenance requirements.
 - b. Washing down surfaces, particularly exterior building elements subject to wind-blown salt spray.
 - c. Recoating exterior and interior protective finishes.

In general, NZ metal roofing materials exposed to rain washing can be expected to comply with NZBC B2 without manual washing, or replacement of protective finishes – but unwashed areas, which includes all wall cladding, may require maintenance.

Where access for maintenance of unwashed areas is impractical, the use of non-ferrous metal cladding may be advantageous in meeting NZBC requirements.

16.2 Inspection

Whether or not regular washing is required by the manufacturer, inspection should be programmed to give early identification of any problem areas. This should occur at all washing intervals or at least annually. Observations from this inspection can be used to determine frequency requirements of general washing, and whether any high-risk areas, for instance around flues or outlets, sheltered areas of roofing, or areas contaminated by birds, require more frequent attention.

16.2.1 Installation

Approved fixers of the members of The New Zealand Metal Roofing Manufacturers Inc (NZMRM Inc) and members of the Roofing Association of New Zealand, (RANZ) will provide a warranty for five years to cover the workmanship and installation of the roof and wall cladding if requested. This means that if the standard of workmanship of the roofing contractor does not comply with this NZ Roofing Code of Practice, and he is a member of RANZ, the installation will be renewed or restored so that it does comply.

This warranty does not extend to any work undertaken on the roof or wall cladding or accessories by other trades or subsequent to completion of the contract by the roofing contractor.

Designers and owners are therefore strongly advised to only deal with members of both of these recognised trade organisations to obtain this warranty.

16.3 Reactive Maintenance

Reactive maintenance is the response to a maintenance need that is visually apparent.

The disadvantage of this model is that preventable permanent damage to the cladding may already have occurred. A proactive scheduled maintenance approach is preferable to achieve optimal life cycle costs of the cladding.

Spray cans should not be used for repairing scratches on pre-painted cladding. Minor surface scratches are best left because they become less noticeable as the coating weathers. If the scratch cannot be seen from the ground, it should be left alone.

16.4 Scheduled Maintenance

Scheduled maintenance is routine maintenance that is performed at pre-planned regular intervals. Inspection should always be an included part of scheduled maintenance.

Washing Cladding

The accumulation of deposits on a metal surface may increase the time of wetness of that surface and also increase the corrosivity of the wetness. Most exposed metal roofing will be adequately cleared of dirt by rain washing, but that is not the case with unwashed areas. Unwashed areas include all wall cladding. It is particularly applicable to areas directly sheltered from the rain, which includes all surfaces that are above a line drawn at 45° to an overhang, such as a soffit, underside of a canopy, under spouting, or garage door head.

Manual washing is required to prevent the accumulation of dirt, debris or other material not removed by rain on these surfaces, carried out at intervals as prescribed by the manufacturer.

Generally, metal wall cladding subject to some direct rain should be washed:

- every 6 months in severe environments; and
- every 12 months in moderate environments.

Generally, other unwashed areas should be washed:

- every 3 months for severe environments; and
- every 6 months for moderate environments.

Washing can be carried out with water and a sponge, soft brush or broom, or water blaster up to 20 mPa, directed away from the overlap of the sheets. Detergent will help remove deposits if it can be applied without increasing the risk of slip and fall.

16.5 Preventative Maintenance

Preventative Maintenance is work that provides extra protection in high-risk and vulnerable areas and is intended to prevent or minimise later requirements for reactive maintenance. It can be achieved by enhancing the product before installation, or by maintaining such areas more regularly than the body of the cladding.

Where the underside of metal roof cladding is subject to contaminants such as salt at the gutter line, an eaves flashing should be inserted under the roof and over the gutter to prevent deposits which lead to 'inside out' corrosion. This flashing can assist where dissimilar metals are used for gutters, or spouting where splashes and contaminants can corrode the roof cladding. (See [8.5.4.4 Eaves Flashing](#)). Where the gutter line micro-environment is likely to be severe, the exposed underside of metal cladding can be painted using a two-pack epoxy primer or elastomeric polyurethane paint before installation.

The most efficient protection of the eaves in severe marine areas is to use a high front spouting system where the front face of the spouting meets or exceeds the height of the roofing crests. These can be custom folded if necessary.

Seagulls perching on ridging, parapets or aerials on buildings can cause damage from rubbish dropped onto the roof, and from their alkali droppings. Discouraging devices such as wire or spikes can be used to prevent this. Unpainted aluminium or AZ coatings are particularly vulnerable to alkali.

Roof Cladding exposed to the elements from the underside should be included in the maintenance schedule for unwashed areas.

16.6 Special Maintenance

Special maintenance is related to preventative maintenance in that it focusses on vulnerable areas.

High-risk areas such as those around flues, near fumes from exhaust fans, under television arials or overhanging trees, or sites prone to mould, lichen, and bird droppings or debris may deteriorate faster than surrounding areas. Proximity to a motorway can cause the collection of contaminants and fine dust, as can nearby earthworks. Shavings from wood processing plants are often blown into crevices under flashings; the shavings retain moisture and can create poultice corrosion. Such areas may require more frequent maintenance than adjacent areas.

Details that trap debris against the roof, such as loose cables or gutter leaf guards, can be removed to allow free draining of these areas. Soil or lush vegetation at the base of wall cladding can also be removed to prolong the life of the cladding material.

16.7 Washing

Regular washing of pre-painted and metallic-coated roofing products increases their durability by reducing attacks from airborne salts and pollutants.

Washing may be carried out with a hose and a soft bristle brush, using fresh water or a 10% solution of household detergent and water followed by a thorough rinse with clean water. Alternatively, low-pressure water blasting can be used at pressures up to 20 MPa, with the jet directed away from openings and sheet laps.

Stronger concentrations of cleaners than those recommended can damage coating surfaces, and avoid using organic solvents and abrasive cleaners. When cleaning coated surfaces, tar and similar substances may be removed with mineral turpentine, but the surfaces should then be washed thoroughly with detergent and water.

Always clean coated surfaces from top to bottom, and rinse immediately and thoroughly with fresh, clean water avoiding over-cleaning or scrubbing, which can damage painted surfaces.

Hard scrubbing of un-weathered bare AZ-coated steel cladding can remove the thin factory-applied clear acrylic film and cause differential weathering, affecting appearance.

If water runoff is used for drinking water, roof outlets must be disconnected before washing any roof or wall cladding using detergents. Care must also be taken not to contaminate waterways.

16.7.1 Lichen And Mould

Lichen is a naturally occurring phenomenon with its spores being dispersed by the wind. Lichen will grow even on inert materials such as G.R.P., glass, and painted or unpainted metal roofs.

Time of wetness of a surface affects lichen and mould growth. Sheltered and shady environments are particularly conducive to its growth and although light-coloured roofs may stay wet for longer than dark roofs, it can equally proliferate in open areas on dark coloured roofs.

Lichen and mould retain moisture, are acidic, and have tiny roots that can penetrate a paint coating. Removal is necessary to prevent damage to the organic coating, but recolonisation is very likely. Where lichen has been treated, regular inspection should be undertaken to curtail spread of re-growth.

16.7.1A Lichen Damaged Roof Cladding



Lichen growth can be removed by washing down the roof or wall cladding, and applying a 2% solution of sodium hypochlorite to all surfaces by low-pressure spray, broom or brush. The surface should be left for 5 minutes but should then be rinsed and thoroughly washed down with cold water. Household bleach contains various concentrations of sodium hypochlorite; therefore, it may be necessary to dilute it.

For example:

- One brand has 30 g/L solution (3%) – to obtain a 2% solution, 2 parts of bleach should be diluted with 1 part of water. (3 - 2 = 1).
- Another brand has 40 grams/L solution (4%) – to obtain a 2% solution, 2 parts of bleach should be diluted with 2 parts of water. (4 - 2 = 2).
- Another brand has 50 grams/L solution (5%) – to obtain a 2% solution, 2 parts of bleach should be diluted with 3 parts of water. (5 - 2 = 3).

Another option is using benzalkonium chloride products which are less corrosive, although slower acting.

16.7.2 Graffiti

Metal wall cladding, like most vertical surfaces, is subject to being defaced by graffiti. Graffiti removal is likely to affect the pre-painted finishes on metal roof and wall cladding, and before removal is attempted a small area should be cleaned as a trial. Graffiti removers may soften the paint, remove the gloss or cause permanent damage.

Do not use MEK (methyl ethyl ketone), toluene, acetone or thinners. Overpainting or replacement are the alternative options.

There are clear anti-graffiti coatings available, but their compatibility with the pre-painted cladding must be checked with their supplier.

16.8 Overpainting

As with all surfaces, the overpaint performance on profiled metal surfaces is dependent on correct surface preparation as well as application. This clause provides generic recommendations; in all cases, the advice of the paint supplier should be studied and followed.

16.8.1 Preparation for Overpainting

1. Thoroughly clean the surface with fresh flowing water and a medium stiff nylon bristle broom, or water blast at 20 MPa. When cleaning the profile to remove dirt, lichen, mould, or algae, care should be taken not to drive water under laps or flashings. Detergent or proprietary roof wash may be added (if safe) to aid dirt removal, but if used should be flushed off with fresh water before drying.
2. Rinse the profile thoroughly, as any remaining dirt will impair subsequent paint adhesion. Particular attention should be given to the drip edge (where the final 15 mm is prone to heavy dirt build-up), and to the coating at the front edge of tile profiles, as dirt collects in this area leading to mould, algae, and lichen growth.
3. Fallout around flues and vents needs to be removed before painting.
4. Allow the roof to dry.

16.8.1.1 White Corrosion

Thorough washing will remove most light deposits, and coating loss may be compensated for with metal-rich primer. Heavy deposits may require the same treatment as rust.

16.8.1.2 Red Corrosion

Manually abrade the red rust down to bright metal, being careful not to overly remove adjacent metallic coatings. Prime with a metal-rich primer and overcoat with an anti-corrosive primer and compatible topcoat.

The use of rust neutralisers is an alternative but must be used with caution. Many are aggressive to remaining metallic coatings, some retain corrosion salts which may cause undercut corrosion in the future, and some, if not completely removed after application, will accelerate corrosion. If considering this path, use it strictly according to the manufacturer's recommendations and requirements.

16.8.2 Application

High-quality, 100% acrylic paint can give a service life of up to 10 years or more when applied to specification on correctly prepared metal surfaces. This lifespan will vary with colour, roof orientation and the aesthetic requirements of the situation. Poor paint curing will downgrade durability.

For many paints, a 50µ dry film build is required to achieve optimal thickness, and typically this requires two layers of top-coat.

Paint should not be applied on wet days when condensation has not completely dried, or when ambient temperatures are expected to reach less than 10° or more than 30° within the drying period. Windy days are also not recommended, as curing is impaired.

Ridge ladders should be fitted with protective buffers or rubber pads as they can cause abrasion damage to pre-coated metal cladding. Where it is possible the painter should walk in the pan, but when it is necessary to step on the rib, (only at the purlin line) attention should be paid to sheet overlaps as these may spring up after a painter's weight is removed and reveal an unpainted line.

Decking profiles have a tight roll-formed bend at the top of the upstand and care is necessary to ensure the specified film build is applied in this area.

Brush Application:

The use of nylon brushes is advisable, and these should be wetted with water prior to use to avoid clogging, and in warm weather should be washed out completely at every rest break, or wrapped in cling film and refrigerated.

Roller Application:

Roller application is not preferred for profiled metal roofing as it tends to apply an uneven paint film thickness. The combined use of brush and roller can give good results with tray profiles.

Dampen the roller prior to use, apply with even pressure, and do not over-roll.

Spray Application:

Spray application in the hands of a skilled applicator can achieve the most consistent film builds. However, airless spray equipment can produce very high film builds giving rise to runs and uneven coatings. When using spray equipment on hot or windy days, the paint spray may dry before it has reached the metal, which leaves a sandy appearance and feel. This is not aesthetically acceptable and will not provide the even coating or durability required.

16.8.3 Unpainted Cladding

The practice of leaving metal-coated roof cladding to weather before painting is no longer required. With the latest developments in primers, roofs can now be painted immediately after installation.

- For un-weathered AZ-coated cladding, only acrylic galvanised iron primers should be used, as solvent-borne primers may damage the coating. A solvent-borne corrosion-resistant galvanised-iron primer should, however, be used for optimum performance on weathered AZ or galvanised-coated cladding. Wash and allow to dry (see preparation above).
- Apply primer.
- Apply two coats of acrylic roofing paint in the selected colour to provide the required paint thickness. (Typically two brush-applied coats achieve 50 µm).

16.8.4

Weathered Pre-Painted Cladding

Repainting painted cladding should be regarded as part of the maintenance programme to extend the life of all metal cladding.

The optimal time to overpaint weathered pre-painted cladding is when the colour has faded excessively, or the topcoat has eroded to the point that the primer is becoming exposed.

The gloss and weathering characteristics of oven-cured and air-dried paints are different, and over time a significant difference in colour may become apparent. Variations in natural light conditions will emphasise these differences producing unacceptable aesthetic variations. For this reason, the whole roof area should be painted and not patch-painted.

- If the over-painting is carried out while the topcoat is still in sound condition, there is no need to use a primer.
- Apply two coats of acrylic roofing paint in the selected colour to provide the paint thickness. (Typically two brush-applied coats achieve 50 µm).

16.8.5

Unweathered Pre-Painted Cladding

It is not easy to obtain adhesion to unweathered pre-painted metal cladding. To prepare such surfaces for painting, abrade all surfaces with fine grit sandpaper, stiff nylon bristle broom or similar, to improve the adhesion. Care should be exercised not to sand through the existing paint surface on external bends.

If the purpose of overpainting new cladding is to obtain a colour finish that is not available in pre-painted material, it is often more economical to order pre-primed material rather than try to overpaint an un-weathered pre-painted surface.

17

Testing and MRM Standards

The NZMRM employs specific testing methods and standards to evaluate the performance of metal roofing components and accessories.

Structural testing of profiled metal closely follows the standards AS 1562 and AS 4040, but differs in minor areas to suit NZ requirements. This testing is used to demonstrate compliance with NZBC B1 – Structure

Compliance with NZBC B2 – Durability is demonstrated by testing of profiled metal and fasteners. This testing is based on AS/NZS2728 and AS/NZS 3566 respectively, again with some modifications.

Also included, are the MRM soft edge standard, and testing and performance standard for pre-painted coil.

17.1 Metal Cladding Testing

This section sets out the testing methodology to evaluate the structural performance of sheet roof and wall cladding systems. Structural Testing covers uniformly distributed load (UDL) and concentrated (point load). These procedures apply to all metals and plastic sheeting.

The UDL test simulates wind uplift by subjecting test specimens to pressure from underneath.

UDL testing is typically carried out to simulate outward loads, where material is restrained by fasteners (or clips) at intermittent points; rather than inward loads where material is restrained linearly by purlins or girts. Even with asymmetrical trapezoidal profiles, failure adjacent to the fastener from the imposition of outward loads is inevitably cause of failure in typical applications.

Testing for inward load can also be conducted, if required.

17.1.1 Standards: AS Standards and COP Testing Standard

There is no specific New Zealand Standard for testing sheet roof and wall cladding. The MRM standard is broadly based on the Australian Standards AS 1562.1:2018 and the AS 4040 series. These Standards are inter-related; AS 1562.1 sets out the performance requirements to be achieved using the test methodology of AS 4040.

The MRM standard differs from the above standards in some significant aspects.

17.1.1.1 UDL Load Testing Standard

AS 1562.1 defines serviceability failure as a level of deflection under load.

In the COP standard, deflection testing is normative for wall cladding and informative for roof cladding. Additionally, the COP standard defines serviceability failure of pierce fastened roofing as permanent deformation, when permanent distortion or splitting occurs around the fastener head. The load at which permanent distortion occurs around the fastener head is defined as serviceability failure and the roof can still resist greater loads, but the damage would affect weather tightness.

17.1.1.1A Deflection Around a Fastener Under Load



17.1.1.1B Permanent Deformation Around a Fastener

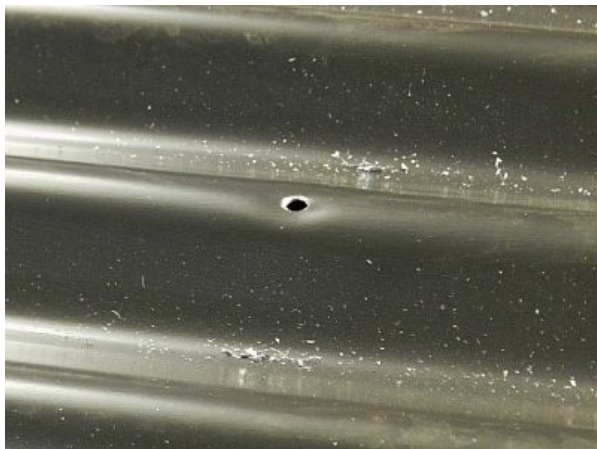

The COP standard does not require cyclic testing, but this can be done if required for other legislations and cyclonic areas.

17.1.1.2 Point Load Testing Standard

AS 1562.1 tests point load only in the path of traffic specified by the manufacturer; i.e., the pans of the profile, and across 2 ribs on narrow profiles.

The COP tests both in the pan (or two ribs) and a single rib, the latter being the less resistant to load. This is to assess the profile strength when laypeople or careless roof traffic fail to adhere to manufacturers' recommendations.

17.1.2 Test Requirements

17.1.2A Uniformly distributed Load (UDL)

1. Serviceability tests:
 - a. Deflection under load, $(\text{span}/120) + p/30$ where p is the maximum distance between fasteners on the support structure. (Informative for roofing, Normative for cladding), or by
 - b. Permanent deformation or cracking around fastener head, or de-indexing or de-clipping of clip fastened profiles. Serviceability failure of clip fastened products may occur when a clip disengages from the central rib, but weathertightness of the lap is not affected and roof can continue to resist increased loads.
2. Strength tests.

Strength tests are defined as: sheet unable to resist further loads i.e. pull-off from clips, buckling, tearing or pull-through of fasteners.

17.1.2B Point Load

1. Resistance to point load on the pan, or to two ribs of narrow profiles, at the weakest point.
2. Residual deflection after imposition of serviceability load, and application of strength load
3. Resistance to point load on a single rib at the weakest point.
4. Residual deflection after imposition of serviceability load, and application of strength load

Load is applied in a downwards direction through a rubber faced pad. The weakest point is generally mid span at rib/pan adjacent to underlap.

17.1.2.1 Supporting Structure and Equipment

17.1.2.1A Uniformly Distributed Load (UDL)

The design of the support system for wind load should consist of a rigid frame airbox, sealed on the bottom and four sides. A fan or blower is required, capable of controlling and maintaining the required test pressure, and pressure measuring devices. The deflection can be measured using several differential displacement transducers and traced and recorded coincidentally with the increasing load. Purlin and end wall positions can be changed to test for multiple spans of different dimensions.

The use of airbags rather than air pressure is not endorsed by the MRM COP

17.1.2.1B Point Load

For point load testing, a means of applying and measuring a continuously increasing load is positioned above the part of the material being tested.

17.1.2.2

Test Set-up

For tests to have value, testers should pay attention to the number of specimens, width of the testing sections, and the number of spans.

17.1.2.2.1

Number of Specimens

For new testing, at least two sets of specimens should be provided for each span-fastener combination. Three is preferred as it results in a higher confidence factor. At least three different spans must be tested, and four is preferred as it gives a more accurate gradient to load-span graphs. For confirmatory testing to review previous test results, smaller sample sizes are acceptable providing results are consistent with previous tests.

17.1.2.2.2

Width of Specimen

The width of a model or the test section of a lapped or interlocking system must be the width represented by at least two sheet side laps. The total width of the testing rig (2.1 m) must be covered by the test sample or other material.

17.1.2.2.3

Number of Spans

For testing continuous spans, the test specimen should incorporate no fewer than five spans; i.e., two end and three intermediate spans. End spans should be two-thirds of the span of internal spans. Tests using four spans (two end spans and two internal spans) or three equal spans may be validated by comparing results against a five-span test of the same sample and adjusting the resultant load tables accordingly.

17.1.3

Testing Procedure

Different testing regimens should be used for UDL testing or Point Load Testing.

17.1.3.1

UDL Testing

The samples are assembled on the testbed in accordance with how they are intended to be used, with the ends and sides sealed to minimise loss of air pressure. Measuring devices for deflection are placed at static points (fasteners) and pan centre at mid-span or as required to measure maximum deflection.

The air pressure is raised incrementally, and the point of deflection failure noted. With pierce-fastened products, signs of imminent deformation are observed. When product nears deformation failure, pressure may be periodically backed off to allow loosening of a fastener to inspect the integrity of cladding profile underneath. The pressure at these points should be noted. The maximum serviceability load test result is the recorded pressure level at the last observation before the onset of failure or the point before which the pressure level recorder showed a sudden small drop signifying profile movement.

More than one serviceability result may be recorded from separate fasteners during a single test if, at the discretion of the testing engineer, the loads imposed on subsequent failure points are equivalent to those imposed on the initial failure point

If lap screws are added for the purpose of attaining failure pressures by decreasing air leakage, these must not be positioned closer than 0.5 m to the nearest purlin.

Clip fastened sections that de-clip at the central rib or de-index on a lap but still resist increased pressure, represents a serviceability failure.

Load is then increased to establish the strength load result. This may be when pierce-fastened cladding pulls fasteners through the profile or clip fastened profile de-clips. Both these actions result in sudden and permanent loss of air pressure and terminate the test. The load at which this occurs, or maximum load achievable due to air leakage, is recorded.

If strength load limits cannot be attained by the testing apparatus, a load of at least 2.0 times the serviceability load must be imposed to demonstrate that the sample failure load is governed by serviceability rather than by strength. If serviceability/strength ratios exceed 2.0 for at least two different spans, it may be assumed that the ratio will be similar on all spans.

Fastener pull-out from testbed purlins is not recorded as a failure as this is independent of the profile strength and is relevant only to the condition of the purlin material on the testbed. Such fasteners may be replaced or repositioned and the test recommenced.

17.1.3.2

Point Load Testing

Concentrated load must be applied in a direction perpendicular to the roof through a circular steel disc of 100 mm diameter faced with a 20 mm thick rubber pad, with a Shore A Durometer hardness of 30-70, to the part of the profile judged to be least resistant to load. See [3.6.1A Point Load Test at the MRM](#).

Where the dimension of the sheeting profile does not allow the use of a 100 (±2) mm diameter pad, the shape must be spread over two ribs by way of a disc and pad of 100 mm width.

The pressure cell and deflection sensor are positioned above the profile pan or rib at mid-span. For Type A (unrestricted access) and B roofs (restricted access), the load is increased to 1.32 kN, the pressure is released and residual deflection measured after 1 minute. Residual deflection must be less than $S/1000$ or 1.5 mm, whichever is higher. The pressure is then increased to failure (or at least 2.41 kN) and noted.

For roofs only intended for Type C (non-trafficable) applications, the initial pressure requirement is 0.60 kN, and secondary load is 1.1 kN.

17.1.3.2A Point Load Testing: Various Profiles

Loads are imposed on the pan to represent controlled traffic

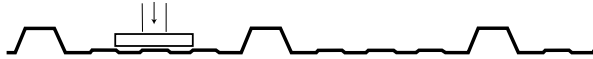

Loads are imposed on a single rib to represent uncontrolled traffic

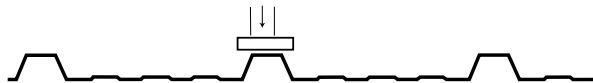

For closed-spaced profiles loads are imposed to both two ribs and one rib



For standard corrugate profiles loads are imposed to both two ribs and one rib



17.1.4 Test Report

The following information must be supplied in the report:

- a. The number of the report and the name of the client.
- b. The date and location of the test.
- c. The name of the testing officer.
- d. The test Procedure – referencing this section of the Code of Practice.
- e. Details of the material under test – Type/Profile/ Material/ thickness/ Spans.
- f. Critical dimensions, particularly crest height and spacing, are measured, recorded and compared to published profile data.
- g. Coil number of material used to run trial material.
- h. Fastener type and fixing pattern.
- i. UDL at deflection limit.
- j. Last noted load prior to UDL serviceability failure, and mode of failure.
- k. Last noted load prior to Strength failure, or maximum load reached
- l. Pass/fail for serviceability point load to pan
- m. Pass/fail for serviceability point load to rib
- n. Pass/fail for strength point load to pan
- o. Pass/fail for strength point load to rib

17.1.5 Publishing Results

Test results must not be published as load-span data. Before they can be offered as a design guide they must be checked and interpreted by an engineer and have suitable factors applied to the test result figures. It is highly desirable that this person has witnessed at least some of the tests being conducted. As fastener pull-out is not included in testing, published load-span tables should encourage the designer to check for pull out values of specified fasteners when fastening into timber or ply less than 30 mm thick, into composite materials, or into steel sections less than 1.2 mm thick.

17.1.5.1 Allowance for Variation

17.1.5.1A Factors to Allow for Variability of Structural Units

No of units tested	Coefficient of Variation (COV)			
	5%	10%	15%	20%
1	1.2	1.46	1.79	2.21
2	1.17	1.38	1.64	1.96
3	1.15	1.33	1.65	1.83
4	1.15	1.3	1.5	1.74
5	1.13	1.28	1.46	1.67
10	1.1	1.21	1.34	1.49
20	1.06	1.13	1.21	1.29
100	1.01	1.01	1.01	1.01

Coefficient of Variation (COV) is derived from Standard Dev / Av for a group of tests. The COV to be applied to a series of tests is the average overall spans measured during a test schedule conducted over a continuous period using identical material.

For serviceability loads, a coefficient of 5% may be assumed unless there is evidence that a higher figure is warranted. For strength loads, a coefficient of 10% may be assumed unless there is evidence that a higher figure is warranted. For clip-fastened products, the applied depreciation factor may not be less than 1.3.

The number of units tested relates to the number of valid results derived from a given fastener configuration and purlin spacing.

For values between those listed in the table, interpolation may be used.

17.1.5.2 Interpreting UDL Load Results

When using data from testing for producing graphs, tables, or other design aids, the following conditions apply:

- Data must not be extrapolated except where a minimum of four span-combinations within the limitations of (b) below can be shown to provide a statistically reliable load span graph. In such cases, an extrapolation of a further $\pm 10\%$ at either end may be calculated.
- Interpolation of data between different spans of a specific type of test is acceptable only in the following circumstances:

- <i> Where the data is taken from tests for a single type, size, and profile of cladding and type and spacing of fastener.
- <ii> Where at least three different spans or support spacings have been tested for the same type, size, and profile of cladding and fastener details, and that in all three tests the failure mode was the same.
- <iii> Where test loads were derived from the same test criteria.

17.1.5.3

Interpreting Point Load Results

Point load requirement for trafficable roofs is defined in NZS 1170 as 1.1 kN, which approximates a 100 kg person on one foot. (Note: many workers carrying tools or equipment exceed this limit.) To allow for statistical variation this is factored by 20% and a test load of 1.32 kN is applied to give a pass/fail.

Type A roof (unrestricted access roofs) is required to withstand a 1.32 kN test load on the rib without deformation or excessive deflection, (serviceability load) and a 2.41 kN strength load.

Type B roof (Restricted access roofs) is required to withstand a 1.32 kN test load in the pan or over two ribs without deformation or excessive deflection, (serviceability load) and a 2.41 kN strength load.

Type C Roof (non-trafficable) is required to withstand a 0.6 kN test load to the pan or over two ribs, and a 1.1 kN strength load. See [3.7.4 Roof Traffic](#).

17.2 MRM Fastener Performance Requirements and Testing

Durability testing of construction fasteners for external cladding, suitable for *Moderate, Severe, Very Severe, and Extreme Environments*.

Typical applications include the fixing of non-ferrous metals, metallic coated steel, and painted steel cladding products to a primary structure. The fasteners may be non-ferrous metal or metallic coated steel.

17.2.1 Requirements for Fastener Testing

17.2.1A Product performance Requirement

1. Fastener systems, including washer, must not deteriorate to the extent that their intended function is impaired, for a minimum of 15 years or the life of the cladding.
2. Fastener systems must not detrimentally affect the material being fastened for a minimum of 15 years or the life of the cladding.
3. Colour adhesion and colour fastness are required to be similar to that of the cladding for a minimum of 10 years.
4. Some shank corrosion is acceptable on screws with shanks exposed to the weather after 10 years.

17.2.1B Product Identification

The head mark on the self-drilling screw shall clearly show the manufacturer's unique head mark and identify the corrosion resistance classification.

17.2.2 Test Panel Requirements

The following is required: An outdoor exposure test site with known first-year mild steel corrosion rate assessed in accordance with ISO 9226.

17.2.2.1 Test Location

The outdoor corrosion test site shall be located in a cleared, well-drained area not subjected to shadowing from trees, buildings or structures. The site should not be subjected to direct splash from any water body or industrial pollution sources. If industrial or geothermal influences are present, the level at the site should be $<90 \mu\text{g}/\text{m}^3$.

17.2.2.2 Site Orientation

The zinc corrosion rate at the outdoor corrosion test site shall be determined in accordance with ASTM G92 and ISO 9226, using mild steel coupons orientated 45° from the horizontal, facing directly into the prevailing winds and surf.

The test panels must face the same direction as the steel coupons.

17.2.2.3 Preparation of Test Panel

A total of 100 screws shall be used for each of the test panel and for the control panel, of which 80 shall be crest fixed and 20 shall be valley-fixed in the configuration shown in [17.2.2.3A Fastener Test Rack](#). The screws may be of a different style, but all screws shall have identical coatings and sealing washers. Screws shall be power-driven into the test panel at their recommended driving speeds and hole shall not be predrilled.

The cladding used in the test panel shall be standard corrugated profile manufactured from metallic coated steel, pre-painted steel, or non-ferrous metal in accordance with the cladding types the fastener is designed for.

Control panels may be used to assess the compatibility of screws and any accessories with their other building materials or test fastener performance against known benchmarks.

17.2.2.3A Fastener Test Rack

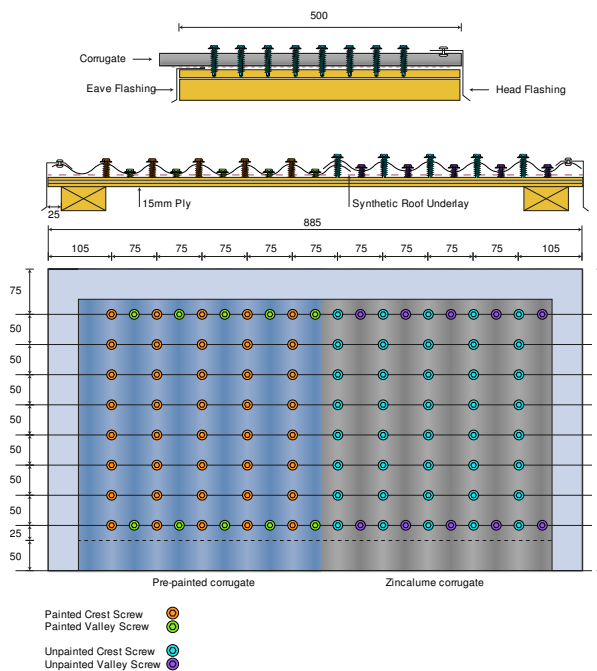

17.2.3 Fastener Performance Testing

All cladding fasteners must be compatible with the material, suitable for the environment and have a durability equivalent to that of the cladding material. All exposed fasteners must have a minimum durability of Class 4.

17.2.3.1 Site Testing

Representative samples shall be exposed in a test site in the manner described in [17.2.2 Test Panel Requirements](#) until 5% of samples show red rust on significant surfaces. The corrosion rating of the site (measured in first-year mild steel corrosion rate) and the time to failure will establish the screw class in accordance with the following graph.

Complete fastener assemblies, including washers and profiled washers, as appropriate, shall be tested as a system.

It cannot be assumed that colour match painted screws will perform as well as unpainted. Both painted and unpainted samples are required to be tested concurrently.

17.2.3.1A Time of Fastener Exposure in Different Environments to Establish Compliance with the MRM COP

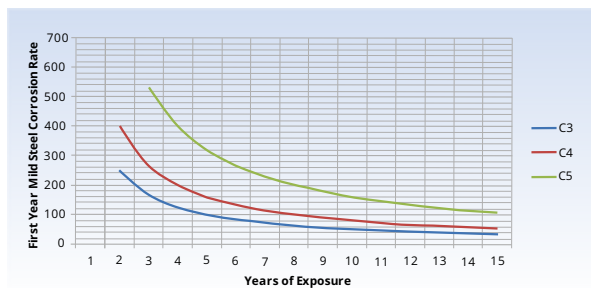

17.2.3.2 Field Performance Validation

The historical performance of fasteners exposed in a given environment over a number of years can be taken as a reliable measure of performance, but confirmatory testing in an approved, monitored location must also be done for validation.

17.2.3.3 Accelerated Testing

The MRM does not acknowledge accelerated testing as proof of performance. However, manufacturers may use it to compare similar coating systems, or for monitoring production quality control.

17.2.3.4 Fastener Shanks

Self-drilling screws which have the shanks and heads produced from the same parent material and undergo the same process and coating do not require the coatings on the shanks to be monitored. Self-drilling screws that have different head and shank material or processing shall require the corrosion resistance of the shank to be monitored as for the head.

17.2.3.5 Sealing Washer Conductivity

The maximum current flow through a sealing washer shall be equal to or below 0.5×10^{-6} A for all thermoset and thermoplastic materials, and shall be tested by the specified procedure in Appendix L. of AS/NZS 3566. Any current flow above this level shall be deemed as not meeting the requirements of this Standard.

17.2.4 Appearance

Ultra Violet Resistance

Fasteners must not fade at more than twice the rate of fade as the roofing material.

General Appearance

Paint coatings should evenly match that of the cladding in terms of colour, and be reasonably intact after installation with approved screw setting methods. The degree of paint loss during installation will be subject to the fasteners' visual exposure, but should not exceed 10% of the exposed surface in any circumstance.

Corrosion

Some visual corrosion is acceptable after 10 years exposure, to the degree that it doesn't affect the integrity of the fastener or the cladding material and appears over less than 10% of the fastener's surface.

17.2.5 Weatherproofing

17.2.5A Mechanical and Thermal Properties of Seals

Mechanical and thermal properties of thermoset and Thermoplastic seals – batch control tests on Finished sealing washer product

Test Standard	Test description	Thermoset seals	Thermoplastic seals
ASTM D2240	Durometer hardness (Shore A)	Tolerance ± 5	Tolerance ± 5
ASTM D412	Tensile strength (min. MPa) Ultimate Elongation (%)	6 Min. 125	3 Min. 200
ASTM D257	DC resistance of finished articles when tested at 1000 V	2000 M Ω	2000 M Ω
	Specific gravity	Tolerance ± 0.02	Tolerance ± 0.02

Every batch of seals shall be tested to meet these requirements. The nominal specific gravity and hardness shall be established for each product, and then tolerances in the table shall apply.

Sealing Properties

The seal for a self-drilling screw should prevent loss of vacuum for 30 seconds when using the test procedure in Appendix K of AS/NZS 3566.

17.2.6 Fastener Performance Test Report

The following information shall be included in the report:

- The report number and date.
- Reference to this test method
- Exposure site classification and identification.
- The date the test sample was exposed.
- The date of failure (5% showing red rust) was observed.
- Exposure time
- Fastener durability designation
- Name of a third-party auditor who monitored the test.
- Fastener Manufacturer and Product designation
- Test panel description, e.g., cladding material, base plates

17.3 MRM Soft Edge Standard

1. Compatibility
Edging materials must be compatible with the flashing and cladding material.
2. Durability
Edging material must have durability no less than the flashing material.
3. Formability
Edging must be able to be dressed to within 3 mm of the pan of all profiles, and 5 mm to the corner of trapezoidal profiles
4. Rigidity
Edging Material must be sufficiently rigid to maintain its form and function in normal wind conditions.
5. Backing
Metallic soft edge may be backed by an inert layer of other material to improve stiffness and shape retention. Perforated metallic soft edging without a back is also acceptable.

17.3.1 Soft Edge Product Technical Statement Requirements

1. Contact
Company name and contact details.
2. Currency
Version and date of PTS. Version and date of PTS which it replaces.
3. Name and description
Product name and brief description of use. How it may be identified from similar products. Materials present in its formulation.
4. Scope of Use
Scope of use including materials to which it may be applied, limitations in use and conditions of use.
5. Installation and maintenance
Installation instructions and maintenance requirements
6. Other
Optional inclusions to the PTS may include Quality Assurance, Product Support and Warranty information.

17.4 MRM Pre-Painted Coil Standard – Performance Requirements

Materials used by New Zealand Metal Roofing Manufacturers Inc. (MRM) members for the manufacture of roofing, cladding and accessories, for use on Residential, Commercial and Industrial buildings, shall comply with this standard.

17.4.1 Part 1: ASNZS/2728:2013

Compliance with the following sections of AS/NZS2728:2013 in their entirety is required. To be clear, if the following sections are interpreted as Informative in AS/NZS 2728:2013, they are considered Normative (i.e., must be complied with) in this NZMRM standard.

- Material must comply with Sections 2.1 through to 2.9 inclusive, including subsections, and section 2.10.2, of AS/NZS 2728:2013, with reference to Section 1 Scope and General.
- AS/NZS 2728:2013 appendices A, C, D, E, F, G, H, I (Cyclic corrosion test only), M and O are all integral parts of this standard.

17.4.2 Part 2: Additional Criteria

In addition to the requirements of Part 1, all prepainted materials must comply with the Hazardous Substances and New Organisms (HSNO) act 1996.

17.4.3 Commentary

Section 1 of AS/NZS 2728:2013 includes clauses on Scope, Referenced Documents, Definitions, Safety, Product Finishes, and Surface Protection

Sections 2.1 through 2.9 of AS/NZS 2728:2013 cover performance requirements. Specifically: Appearance, Gloss, Dry Film Thickness, Impact Resistance, Adhesion, Scratch Resistance, Durability of Organic Film, and Humidity Resistance.

Section 2.10.2 of AS/NZS 2728:2013 is the Cyclic Corrosion test. Note the MRM standard does not include the 2.10.1 Salt Spray Test.

17.4.4 Appendices of AS/NZS 2728:2013 included as Normative in the MRM Standard

- A Purchasing Guidelines** – Gives additional information, specific requirements and fitness for purpose.
- C Atmospheric Environments** – Categorises environments for determination of performance level requirements of clause 2.8.
- D Test Panels** – Specifies preparation of test samples for exposure testing.
- E Reverse Impact Testb** – Procedure required for testing impact resistance to the reverse side

F T-Bend Adhesion Test – Procedure to be used for T bend adhesion

G Ball Adhesion Test – Adhesion test procedure for laminate products.

H Durability and Corrosion Resistance – Procedure for 4 year exposure test to determine resistance to UV exposure and marine environment. Note: Compliance with this test has been interpreted as being Informative in AS/NZS 2728:2013. This test procedure is required for demonstration of compliance with this MRM standard.

I Accelerated Corrosion test – Note the MRM standard only requires that the Cyclic corrosion test be carried out.

M Safety Requirements – Guidelines on safe applications of paint coatings

O Colour Durability – This four year Colour Durability Expectations is Normative in the MRM standard and Informative in AS/NZS 2728:2013.

17.4.5

Appendices of AS/NZS2728:2013 considered Informative in the MRM Standard:

B Demonstrating Compliance – Statistical sampling and Product Certification.

J Test Sites – Categorisation of specific test sites for testing

K Advice on weathering performance – Loss of Gloss, Chalking, Checking, Colour Fade and Erosion.

L Storage and Handling

17.4.6

Copyright Acknowledgement

The referenced standard AS/NZS NZS 2728:2013 – *Prefinished/prepainted sheet metal products for interior/exterior building applications – performance requirements* is provided by Standards New Zealand under licence 001027. Please refer to the Standard for full details, available for purchase from www.standards.co.nz

18

Useful Information

Useful tools and tables to do calculations and conversions for roof and wall cladding. Just choose the correct online calculator, input your values, and get the answer.

18.1 Conversion Factors

1	=	1013.25
		millibar

18.1A Measurement Conversions

<i>To convert from this</i>	<i>into this</i> <i>To convert this back</i>	<i>multiply by this</i> <i>divide by this</i>
<i>atmosphere</i>	<i>millibar</i>	<i>1013.25</i>
<i>atmosphere</i>	<i>pascal</i>	<i>101.325</i>
<i>cubic foot</i>	<i>cubic metre</i>	<i>0.028317</i>
<i>cubic inch</i>	<i>cubic millimetre</i>	<i>16387.1</i>
<i>cubic yard</i>	<i>cubic metre</i>	<i>0.764555</i>
<i>foot</i>	<i>metre</i>	<i>0.3048</i>
<i>foot per minute</i>	<i>metre per minute</i>	<i>0.3048</i>
<i>foot per minute</i>	<i>metre per second</i>	<i>0.00508</i>
<i>foot per second</i>	<i>metre per second</i>	<i>0.3048</i>
<i>foot pound force per second</i>	<i>watt</i>	<i>1.35582</i>
<i>gallon (Imp)</i>	<i>litre</i>	<i>4.54609</i>
<i>gallon (US)</i>	<i>litre</i>	<i>3.78541</i>
<i>inch</i>	<i>metre</i>	<i>0.0254</i>
<i>inch</i>	<i>millimetre</i>	<i>25.4</i>
<i>inch mercury</i>	<i>kilopascal</i>	<i>3.38638</i>
<i>inch water gauge</i>	<i>kilopascal</i>	<i>0.248642</i>
<i>kilogram</i>	<i>kN</i>	<i>102</i>
<i>kilometre per hour</i>	<i>knot</i>	<i>0.539</i>
<i>knot</i>	<i>kilometre per hour</i>	<i>1.852</i>
<i>knot</i>	<i>nautical mile/h</i>	<i>1</i>
<i>knot</i>	<i>ft/h</i>	<i>6080</i>
<i>knot</i>	<i>metre per second</i>	<i>0.515</i>
<i>metre Head of water</i>	<i>kPa</i>	<i>9.8</i>
<i>mile</i>	<i>kilometre</i>	<i>1.609344</i>
<i>mile per hour</i>	<i>kilometre per hour</i>	<i>1.609344</i>
<i>millimetre mercury</i>	<i>kilopascal</i>	<i>0.133322</i>
<i>millimetre water gauge</i>	<i>pascal</i>	<i>9.78904</i>
<i>MPa</i>	<i>kip</i>	<i>6.895</i>
<i>ounce</i>	<i>gram</i>	<i>28.3495</i>
<i>ounce per square foot</i>	<i>gram per square metre</i>	<i>305.152</i>
<i>ounce per square yard</i>	<i>gram per square metre</i>	<i>33.9057</i>
<i>pound</i>	<i>kilogram</i>	<i>0.45359237</i>
<i>pound force</i>	<i>newton</i>	<i>4.44822</i>

<i>To convert from this</i>	<i>into this To convert this back</i>	<i>multiply by this divide by this</i>
<i>pound force foot</i>	<i>newton.metre</i>	<i>1.35582</i>
<i>pound force inch</i>	<i>newton.metre</i>	<i>0.112985</i>
<i>pound force per square foot</i>	<i>kilopascal</i>	<i>0.0479</i>
<i>pound force per square inch</i>	<i>bar</i>	<i>0.69</i>
<i>pound force per square inch</i>	<i>pascal</i>	<i>6894.76</i>
<i>pound force per square inch</i>	<i>kilopascal</i>	<i>6.89476</i>
<i>pound force per square inch</i>	<i>megapascal</i>	<i>0.006895</i>
<i>pound per cubic foot</i>	<i>kilogram per cubic metre</i>	<i>16.0185</i>
<i>pound per foot</i>	<i>kilogram per metre</i>	<i>1.48816</i>
<i>pound per square foot</i>	<i>kilogram per square metre</i>	<i>4.882</i>
<i>square foot</i>	<i>square metre</i>	<i>0.092903</i>
<i>square foot per ton</i>	<i>square metre per tonne</i>	<i>0.091436</i>
<i>square inch</i>	<i>square millimetre</i>	<i>645.16</i>
<i>square mile</i>	<i>square kilometre</i>	<i>2.59</i>
<i>square yard</i>	<i>square metre</i>	<i>0.836127</i>
<i>Steel thickness in mm</i>	<i>Weight of steel kgs/m²</i>	<i>7.85</i>
<i>ton</i>	<i>tonne</i>	<i>1.01605</i>
<i>ton force foot</i>	<i>kilonewton metre</i>	<i>3.03703</i>
<i>ton force per square inch</i>	<i>megapascal</i>	<i>15.4443</i>
<i>ton per cubic yard</i>	<i>tonne per cubic metre</i>	<i>1.32894</i>
<i>ton, freight (40 ft³)</i>	<i>cubic metre</i>	<i>1.13267</i>
<i>yard</i>	<i>kilometre</i>	<i>0.000914</i>

Water 0° – 100° increases in volume by 4.4%

1 litre = 1 kg = 0.001 m³

1 m³ = 1000 litres

Weight of steel kgs/m² = thickness in mm x 7.85

1 kN = 102 kg

1 kip = 6.895 MPa

18.2 Pitch & Rise Calculator

The relationship between the pitch, fall or rise and the horizontal, is the relationship between the opposite and the adjacent sides of a right angled triangle.

This is known as the tangent of the angle. ($\tan \phi$) with the opposite side being the rise and the adjacent side the horizontal distance.

Enter any two values on the illustration for live calculations.

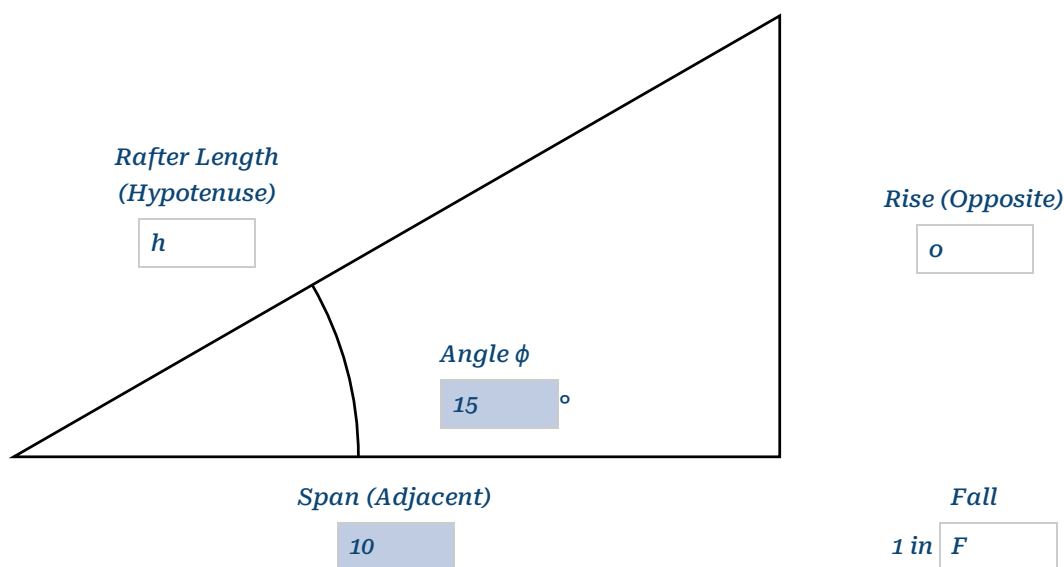

18.2A Rafter, Hip and Rise Chart

Pitch	Rafter length per metre span	Hip/Valley Length per metre span	Vertical Rise per metre span	Valley Angle
0.5	1.000	1.414	0.009	179°
1	1.000	1.414	0.017	179°
1.5	1.000	1.414	0.026	178°
2	1.001	1.415	0.035	177°
3	1.001	1.415	0.052	176°
4	1.002	1.416	0.070	174°
5	1.004	1.417	0.087	173°
6	1.006	1.418	0.105	172°
7	1.008	1.420	0.123	170°
8	1.010	1.421	0.141	169°
9	1.012	1.423	0.158	167°
10	1.015	1.425	0.176	166°
11	1.019	1.428	0.194	164°
12	1.022	1.430	0.213	163°

13	1.026	1.433	0.231	162°
14	1.031	1.436	0.249	160°
15	1.035	1.439	0.268	159°
16	1.040	1.443	0.287	158°
17	1.046	1.447	0.306	156°
18	1.051	1.451	0.325	155°
19	1.058	1.456	0.344	153°
20	1.064	1.460	0.364	152°
21	1.071	1.465	0.384	151°
22	1.079	1.471	0.404	149°
23	1.086	1.477	0.424	148°
24	1.095	1.483	0.445	147°
25	1.103	1.489	0.466	145°
26	1.113	1.496	0.488	144°
27	1.122	1.503	0.510	143°
28	1.133	1.511	0.532	141°
29	1.143	1.519	0.564	140°
30	1.155	1.528	0.577	139°
31	1.167	1.537	0.601	137°
32	1.179	1.546	0.625	136°
33	1.192	1.556	0.649	135°
34	1.206	1.567	0.675	133°
35	1.221	1.578	0.700	132°
36	1.236	1.590	0.727	131°
37	1.252	1.602	0.754	130°
38	1.269	1.616	0.781	128°
39	1.287	1.630	0.810	127°
40	1.305	1.644	0.839	126°
41	1.325	1.660	0.869	125°
42	1.346	1.677	0.900	124°
43	1.367	1.694	0.933	122°
44	1.390	1.712	0.966	121°
45	1.414	1.732	1.000	120°
46	1.440	1.753	1.036	119°
47	1.466	1.775	1.072	118°
48	1.494	1.798	1.111	117°
49	1.524	1.823	1.15	115°
50	1.556	1.849	1.192	114°
51	1.589	1.877	1.235	113°
52	1.624	1.907	1.280	112°
53	1.662	1.939	1.327	111°
54	1.701	1.973	1.376	110°
55	1.743	2.010	1.428	109°
56	1.788	2.049	1.483	108°
57	1.836	2.091	1.540	107°
58	1.887	2.136	1.600	106°

59	1.942	2.184	1.664	105°
60	2.000	2.236	1.732	104°

18.3

Material Density, Melting Point, Expansion And Modulus

18.3A Density, Melting Point, Expansion and Young Modulus

Material	Density kg/m ³	Melting point °C	Expansion mm/10m/100°C	Youngs modulus Gpa
Air	1.29			
Air acetylene		2500*		
Aluminium, rolled	2710	658	24	69
Brass	8330	900	18	
Carbon Dioxide 0°C	1.99			
Cement	1281			
Concrete, reinforced 2% steel	2420			
Copper	8938	1083	17	131
Glass	2787	850	9	
Gold	19290	1063	14	
Hydrogen 0°C	0.0897			
Helium 0°C	0.178			
Ice	913	0		
Iron, cast	7208	1530	12	179
Lead, rolled	11325	327	29	16
Nitrogen 0°C	1.25			
Oxygen 0°C	1.43			
Oxy acetylene		4400*		
Pinus Radiata	609			6
Polycarbonate	1244	133	64	
Polyester	1299	245	80#	
P.V.C.	1465	86	140	
Silver	10500	960	19	
Silver solder		735		
Easy-flo		630		
Solder Lead 50%	9302	210		
(Eutectic) Lead 33%/tin 67%	8615	180		
Snow: fresh	96	1		
wet compact	320			
Stainless Steel 304	8080	1425	17	193
Stainless Steel 316	8080	1385	16	193
Steel, low carbon	7850	1350	12	200
Tin	7280	231	27	
Water: fresh 4°C	1000			
Water: fresh 20°C	988			
Water: fresh 100°C	958			
Water: salt	1009-1201			
Zinc: rolled	7192	419	29	

* max flame temperature

glass reinforced polyester GRP expansion = 22

To convert Centigrade to Farenheit.

To convert Farenheit to Centigrade.

$$C^{\circ} = F^{\circ} - 32^{\circ} \times .56$$

$$F^{\circ} = C^{\circ} \times 1.8 + 32^{\circ}$$

18.3.1 Thermal Conductivity K

18.3.1A Thermal Conductivity

Material	W/mK
Copper	385
Aluminium	205
Zinc	108
Steel	50
Lead	35
Stainless Steel	16
Ice	2
Glass	1.05
Concrete	0.94
Brick	0.8
Water (20°C)	0.56
Timber (Pine)	0.14
Snow	0.1
Kraft building paper	0.07
Fibreglass	0.035
Rockwool	0.035
Polystyrene	0.035
Air (20°C)	0.025
Polyurethane (Rigidised)	0.016

18.4 Decadic Number System

18.4A Decadic Numbers

Symbol	Designation	Long Measure		Multiplier
T	Tera	Billion (Trillion		10^{12}
G	Giga	Milliard (Billion USA)		10^9
M	Mega	Million		10^6
ma	Myria	Ten thousand	mam Myriametre	10^4
k	Kilo	Thousand	km Kilometre	10^3
h	Hecto	Hundred	hm Hectometre	10^2
da	Deca	Ten	dam Decametre	10
		One	m Metre	1
d	Deci	Tenth	dm Decimetre	10^{-1}
c	Centi	Hundredth	cm Centimetre	10^{-2}
m	Milli	Thousandth	mm Millimetre	10^{-3}
µ	Micro	Millionth	Micrometre (Micron)	10^{-6}
n	Nano	Milliardth	nm Nanometre	10^{-9}
p	Pico	Billionth	pm	10^{-12}

18.4.1 International Symbols

18.4.1A The Greek Alphabet

Upper		Lower		Greek
A	A	α	a	alpha
B	B	β	b	beta
Γ	G	γ	g	gamma
Δ	D	δ	d	delta
E	E	ε	e	epsilon
Z	Z	ζ	z	zeta
H	H	η	h	eta
Θ	Q	θ	q	theta
I	I	ι	i	iota
K	K	κ	k	kappa
Λ	L	λ	l	lambda
M	M	μ	m	mu
N	N	ν	n	nu
Ξ	J	ξ	j	xi
O	O	ο	o	omicron
Π	P	π	p	pi
P	R	ρ	r	rho
Σ	S	σ	s	sigma
T	T	τ	t	tau
Υ	Y	υ	y	upsilon
Φ	F	φ	f	phi
X	X	χ	x	chi
Ψ	C	ψ	c	psi
Ω	V	ω	v	omega

18.5 Geometry And Measurement

Enter values below for automatic calculations

a	= area		
b	= base	<input type="text"/>	
d	= diameter	<input type="text"/>	<input type="text"/>
h	= height	<input type="text"/>	
l	= length	<input type="text"/>	
r	= radius	<input type="text"/>	
π	= 3.1416		
c	= circumference = $2\pi r$ or $22/7d$		

Areas

Circle	= πr^2 or $0.7854 d^2$
Square, rectangle, rhombus or rhomboid	= bh
Triangle	= .5 bh
Trapezoid	= .5 two parallel sides x h
Side of square of area equal to circle	= 0.8862 d
Diameter of circle equal in area to square	= 1.1284 side of square
Parabola	= .66 bh
Ellipse	= 0.7854 d1 d2

Area of any figure of four or more unequal sides is found by dividing it into triangles, finding areas of each and adding together.

Surface Area

Cube	= $6b^2$
Sphere	= πd^2
Lateral surface area of regular figure	= .5 cbh (<i>slant height</i>)
Cylinder (Lateral surface area)	= πdh
Cylinder (Total surface area)	= $\pi dh + 2\pi r^2$
Cone (Total surface area)	= ab + c of base x .5h (<i>slant height</i>)

Volume

Cube	= b^3
Sphere	= $0.5236 d^3$
Pyramid	= .33 abh
Cone	= .33 abh
Cylinder	= $\pi r^2 h$

Table of polygons

S	= side of polygon.
R	= Radius of circumscribed circle.
r	= Radius of inscribed circle.
A	= Angle formed by the intersection of the sides.

Name	No of sides	Angle
Trigon	3	60°
Pentagon	5	108°
Hexagon	6	120°
Octagon	8	135°
Decagon	10	144°

Area of any regular polygon = Radius of inscribed circle x 1/2 number of sides x length of one side.

Right Angle Triangles

Enter any two values on the illustration for live calculations.

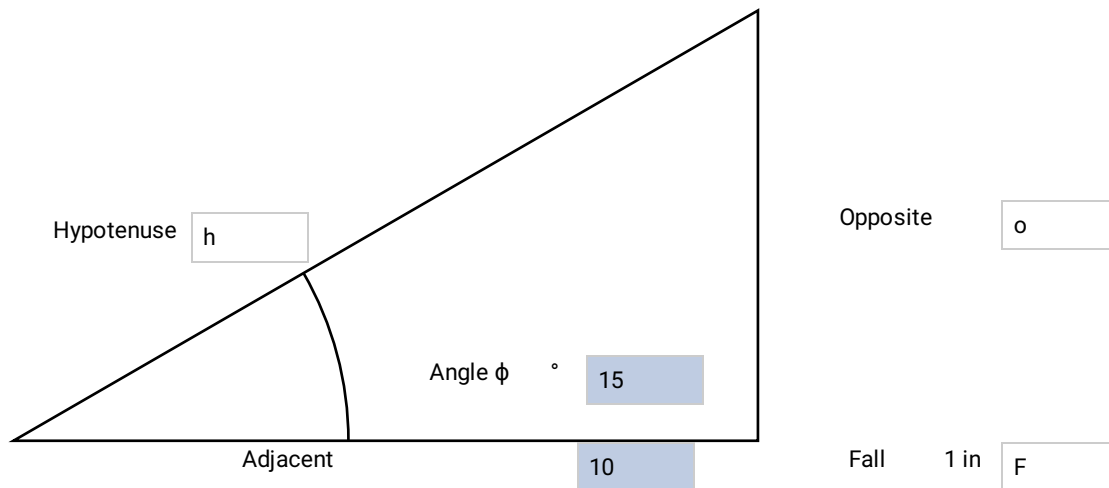

18.5A Triangle Values

Right angle triangles

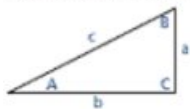

Find	Given	Solution
A	a, b	$\tan A = a / b$
	a, c	$\sin A = a / c$
	b, c	$\cos A = b / c$
B	a, b	$\tan B = b / a$
	a, c	$\cos B = a / c$
	b, c	$\sin B = b / c$
a	A, b	$b \tan A$
	A, c	$c \sin A$
	b, c	$\sqrt{c^2 - b^2}$

b	A, a	$a / \tan A$
	A, c	$c / \cos A$
	a, c	$\sqrt{c^2 - a^2}$
c	A, a	$a / \sin A$
	A, b	$b / \cos A$
	a, b	$\sqrt{a^2 + b^2}$
Area	a, b	$ab / 2$

18.5B To Find a Right Angle

Draw a line ab 3x long. At point a scribe an arc 4x long.
At point b scribe an arc 5x long to intersect a c.
Join ac and b, ac and ab are at 90°.

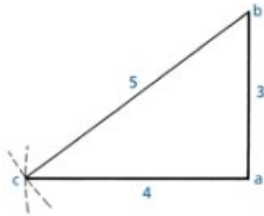

18.6 Velocities

18.6A Velocity

Unit	m/s	kms/h	mile/h
mile / hour	0.44704	1.60934	1
m/s	1	3.6	2.23694
km/h	0.277778	1	0.62137

Velocity is the distance travelled in one second (m/s).

The following speeds are approximate and are assumed to be constant and in a straight direction and therefore are also the velocity.

Description marked R are speed records.

18.6B Velocity Comparison

	<i>m/s</i>	<i>km/h</i>	<i>mile/hour</i>	<i>Beaufort Scale</i>
<i>Calm</i>	0	<1	0	<i>Smoke rises vertically</i>
<i>Light Air</i>	0.8	3	2	<i>1 Smoke rises on angle</i>
<i>Man walking</i>	1.5	5.5	3.5	
<i>Light breeze</i>	2.5	9	5.6	<i>2 Feel wind on face</i>
<i>Gentle breeze</i>	4.5	16	10	<i>3 Flags extend</i>
<i>Moderate breeze</i>	7	25	15.5	<i>4 Raises dust</i>
<i>Fresh breeze</i>	10	35	22	<i>5 Trees sway, waves</i>
<i>Runner 100m R</i>	10	35	22	
<i>Strong breeze</i>	12.5	45	28	<i>6 Telegraph wires whistle</i>
<i>Racehorse trotting R</i>	15	54	33	
<i>Moderate gale</i>	15.5	56	35	<i>7 Difficult to walk</i>
<i>Fresh gale</i>	18.5	67	42	<i>8 Branches break</i>
<i>Racehorse R</i>	19	68	42.5	
<i>Ostrich</i>	20	72	45	
<i>Racing cyclist R</i>	22	79	49	
<i>Strong gale</i>	23	82	51	<i>9 Slight building damage</i>
<i>Whole gale</i>	26.5	96	60	<i>10 Trees uprooted</i>
<i>N.Z. Road speed limit</i>	28	100	62.5	
<i>Skier downhill</i>	28	100	62.5	
<i>Storm</i>	31	111	69	<i>11 Widespread damage</i>
<i>Low wind speed NZS 3604</i>	32	115	71	
<i>Hurricane</i>	33.5	120	75	<i>12 Severe damage</i>
<i>Medium wind speed NZS 3604</i>	37	133	83	
<i>High wind speed NZS 3604</i>	44	158	98	
<i>AS/NZS 1170</i>	45	162	101	

	<i>m/s</i>	<i>km/h</i>	<i>mile/hour Beaufort Scale</i>
<i>Swift - fastest bird</i>	47	169	105
<i>Very high wind speed NZS 3604</i>	50	180	111
<i>AS/NZS 1170 (Cook Strait)</i>	51	184	114
<i>Moderate cyclone</i>	55	198	153
<i>Tennis serve R</i>	66	238	148
<i>Bullet train (Japan)</i>	69	248	154
<i>Severe tropical cyclone</i>	70	252	157
<i>TGV express train</i>	77	277	172
<i>Wind R</i>	103	371	230
<i>Boeing 747</i>	256	920	572
<i>Sound in air</i>	333	1199	743
<i>Land speed R</i>	341	1228	763
<i>Rotation of earth at equator</i>	465	1674	1040
<i>Concorde</i>	649	2336	1452
<i>303 Bullet</i>	792	2851	1772
<i>Lockheed Blackbird R</i>	981	3529	2193
<i>Moon round the earth</i>	1000	3600	2237
<i>Sound through steel</i>	5100	18360	11408
<i>To escape earth's gravity</i>	7823	28163	17500
<i>Fastest man has travelled</i>	11176	40234	25000
<i>Earth round the sun</i>	29700	106920	66437
<i>Pioneer space probe</i>	66720	240192	149248
<i>Light and electric waves</i>	299388000	1077614064	669600000 186,000 miles/sec

18.7 Cricket Penetration Patterns

When cricket and diverter penetration flashings are used, the pitch of the cricket valley will always be less than the pitch of the roof.

To find the pitch of a roof or valley, a simple method is to use a 1m long level measuring stick and measure the rise as shown in drawing 18.7A **Measuring Stick Method**. The relationship between the rise and the horizontal distance is known as the tangent of the angle and is calculated by using $\tan f = O/A$ (being the opposite side divided by the adjacent side). See 18.2 **Pitch & Rise Calculator**.

18.7A Measuring Stick Method

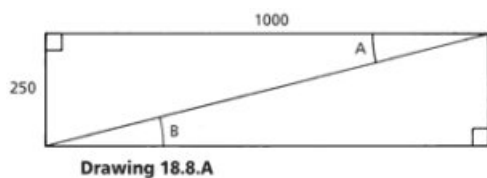

$$250/1000 = 0.25 = 14^\circ \text{ (1 in 4)}$$

N.B. Angles A and B are equal.

It is possible to obtain the length of the hypotenuse by using $\sqrt{a^2 + b^2}$

Cricket flashings as described in section 6 can be made to suit any penetration width, any cricket flashing depth to width ratio and roof pitch down to 3°. For simplicity, three angles have been selected.

$$f X = 45^\circ$$

$$f Y = 27^\circ$$

$$f Z = 18^\circ$$

VARIATION OF CRICKET VALLEY DESIGN DEPENDENT ON DEPTH AND ROOF PITCH

Penetration Width = 2A

Depth = D

Valley = V

18.7B Cricket Variations

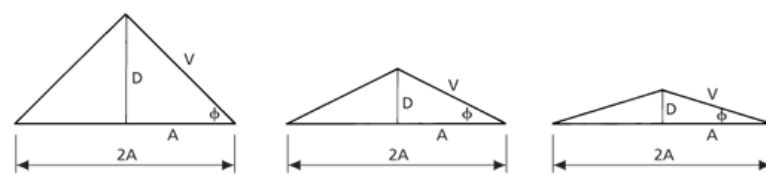

$f X = 45^\circ$	$f Y = 27^\circ$	$f Z = 18^\circ$
$D = A$	$D = 1/2A$	$D = 1/3A$
$V = \sqrt{2} = 1.42$	$V = \sqrt{1.25} = 1.118$	$V = \sqrt{1.11} = 1.054$

To find the cricket valley pitch when the roof pitch is known, it is necessary to find the depth (D) of the cricket. If the depth of the cricket is half of the width of the penetration, as shown for 'Cricket X' the angles are at 45° and there is a defined relationship between the length of the valley of the cricket and the width of the penetration and also between the pitch of the valley of the cricket and the pitch of the roof.

This is $1 : \sqrt{2} = 1.42$, which means that to maintain the desired 3° fall in the cricket valley, the minimum roof pitch (4°) can be calculated using table 15.8.

If the depth of the cricket is a quarter or a sixth of the width of the penetration, there are also defined relationships between the pitch of the valley of the cricket and the pitch of the roof.

These are described in table 18.7C Relationships between the pitch of the valley of the cricket and the pitch of the roof as 'Cricket Y' and 'Cricket Z'.

All figures comply with the minimum fall of 1.5° , but all the bold figures will provide a 3° cricket valley pitch. This methodology is valid for all sizes of penetration. However, there is a point at which, having a design with a wide penetration and a low pitch, it becomes uneconomic to pursue the ideal 3° fall in the cricket valley. When the roof pitch is known, the minimum allowable fall of the cricket valley pitch (1.5°) can then be read from table 15.8.

It is permissible to lower the valley pitch because 1.5° allows sufficient fall to clear debris from the valley and therefore qualifies as a warrantable flashing.

A diverter flashing without a cricket design only shifts the position of the cricket to the top over-flashing of the penetration as shown on drawing 9.7.6B Cricket Flashings, unless the penetration is rotated 45° as shown on drawing 9.7.6C Diverter Flashings.

18.7C Relationships between the pitch of the valley of the cricket and the pitch of the roof

ROOF PITCH	3°	4°	5°	6°	7°	8°	9°	10°
TANGENT	.0524	.0699	.0875	.1051	.1228	.1405	.1584	.1763
CRICKET X	2°	3°	3.5°	4.5°				10°
CRICKET Y	1.5°	1.75°	2.25°	2.75°	3.25°	8°	9°	10°
CRICKET Z	n/a	n/a	1.5°	2°	2.25°	2.5°	3°	3.5°

PROCEDURE TO MAKE A HALF PATTERN FOR A CRICKET PENETRATION FLASHING

Example:

A net penetration width is 550 mm wide and gross width to the flat of the pans is 620 mm (2A).

The back curb is required to have a fall of 3°.

The roof pitch is 7°.

From Table 18.7C Relationships between the pitch of the valley of the cricket and the pitch of the roof . select the cricket - Type Y

Given:

Half the width of the cricket

$$A = 310\text{mm}$$

Depth of the Y cricket from drawing 15.8.B ($D=1/2A$)

$$D = 155\text{mm}$$

Height of the side curb

$$H = 130\text{mm}$$

Height to the top of the cricket

$$Hc = 70\text{mm}$$

$$H - Hc = Hr$$

$$Hr = 60\text{mm}$$

From Drawing 15.8.C

Find the length of V, S and R.

Right angle triangle, therefore, the length of V.

$$\begin{aligned} V &= \sqrt{A^2 + D^2} \\ &= 346 \text{ mm} \end{aligned}$$

Right angle triangle, therefore, the length of R.

$$\begin{aligned} R &= \sqrt{Hc^2 + D^2} \\ &= 170 \text{ mm} \end{aligned}$$

Right angle triangle, therefore, the length of S.

$$\begin{aligned} S &= \sqrt{A^2 + Hc^2} \\ &= 318 \text{ mm} \end{aligned}$$

18.7D Cricket Pattern

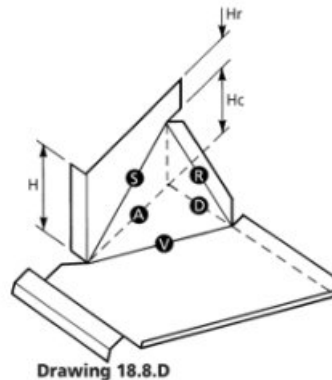
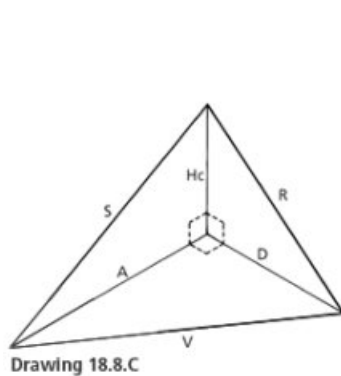

DRAW A HALF PATTERN

1. Draw a dotted line K - L length equal to A
2. From L draw a dotted line at right angles L - M length equal to D
3. Draw the line K - M (length equal to V)
4. With centre M scribe an arc length equal to R

5. With centre *K* scribe an arc length equal to *S*
6. From their point of intersection, *N* draw a line to *K* and also to *M*
7. With centre *K* scribe an arc length equal to *H*.
8. With centre *N* scribe an arc length equal to *Hr*.
9. Draw a line as a tangent to the two arcs
10. From point *K*, draw a line at right angles to intersect this line at *O*.
11. From *O* measure length *A* to a point *P*
12. The shape *K-M-N-P-O* is the net cricket pattern

18.7E Drawing a Cricket Half-Pattern

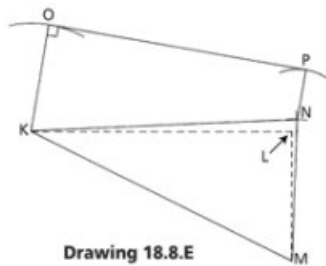

Drawing 18.8.E

18.7F Assembling a Cricket Penetration

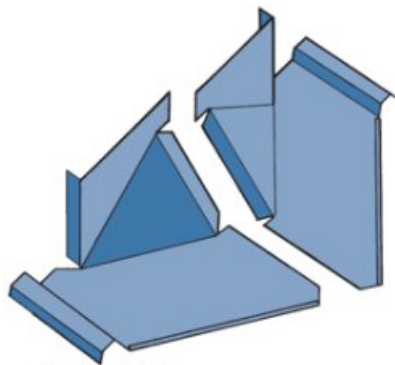

Drawing 18.8.F

18.8 Sheet Metal Work For Roofing Contractors.

When forming various flashings in sheet-metal the Roofing Contractor is required to know how to cut the material in order to obtain the desired shape.

Basic knowledge of geometrical drawing and mensuration is required and this section explains the methods which are employed to ensure accurate results.

A straight line. A straight line is a line drawn in the shortest manner between two given points, so any other line between these points is a curved line.

18.8A Parallel Lines



Parallel lines are lines which, when extended, do not touch. Given a line CD, to draw a parallel line set a compass to the required distance apart and with C and D as centres, describe two arcs. A line drawn as a tangent to both arcs will be a parallel line to CD.

18.8B Perpendicular Line

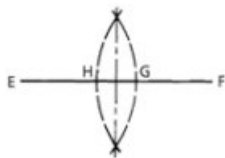

To draw a perpendicular line. Given a straight line EF, set a compass to any distance more than half the distance EF and, with E and F as centres, describe arcs of radius EG and FH.

A line drawn through the points of intersection of these arcs is perpendicular to EF and bisects the distance EF.

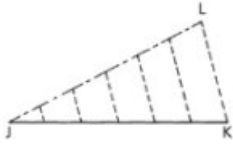
18.8C Dividing a line into equal parts

To divide a line into any number of equal parts. Given a straight line JK , draw another line JL at any suitable angle and no particular length. Set off on JL , at any reasonable distance apart, a number of equal spaces similar in number to the parts into which JK is to be divided.

Connect L and K with a line, and parallel to this draw other lines through points on JL . These divide JK into the required number of equal parts.

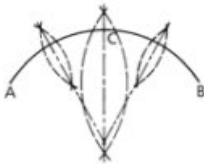
18.8D Bisecting and Arc

Given an arc AB , set a compass to a distance a little more than half that between the ends and with A and B as centres, describe arcs of equal radii.

A line drawn through the points of intersection will bisect AB . This method can be employed to divide the arc into any number of even parts by repetition. Further, the method may be used to find the centre of any given arc by further bisecting AC and CB .

Lines taken through the intersecting points of these latter arcs, when produced, will intersect at the centre of the arc AB .

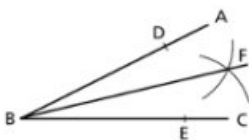
18.8E Bisecting an Angle

Given an angle ABC , set off equal distances BD and BE and with D and E as centres and a compass set at any reasonable radius, describe arcs to intersect in F . A line drawn through B and F bisects the angle.

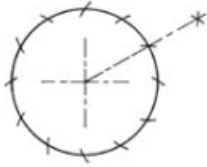
18.8F Dividing a Circle into Six Equal Parts

Set a compass to the radius of the circle and step this distance off along the circumference. Further division into 12 parts may be done by bisecting one part, and again stepping off with the radius of the circle

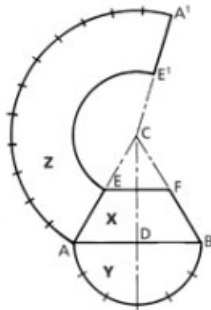
18.8G Developing the Frustum of a True Cone

Draw the elevation X with base diameter AB, the vertical height CD to the desired cone angle and add the section line EF to the elevation. With centre D and radius DA describe a semicircle Y on the base, and divide the circumference of this into six equal parts.

To draw the development Z: With centre C and radius CB, describe an arc AA' whose length equals the circumference of cone base.

This may be obtained by marking off along the arc from A spaces equal to parts in the semicircle Y but double in number.(12)

With C as centre and radius CE, draw the arc EE1 and add the line CA'.

The figure AA1E1E is the development Z of the frustum.

To do this, drop a perpendicular from F to F¹ and extend the base line AB.

An offset diagram is now made by measuring distances B¹F¹, B¹G, and B¹H, setting these off from F¹ on base line AB and drawing lines to F.

The lengths FF¹, FG, and FH, etc., are now true lengths.

To draw the development Z:

Draw a centre line C¹O. At right angles to C¹ draw A²B² equal to AB.

From C¹, set off distance C¹F¹, equal to FB.

Join A² and B² to F¹. With centre A² and radius F¹G, draw a short arc to be cut by an arc of F¹G

radius struck from F^1 to obtain point G^1 .

Similarly, with A^2 as centre and radius FH , draw an arc, to be cut by an arc of GH radius struck from point G^1 , thus obtaining point H^1 .

Draw a line through, A^2 and H^1 and produce same to intersect the centre line C^1O at O .

Repeat the process with, B^2 as centre for long radii, thus completing one quarter of the whole development.

To complete the pattern, draw a curve through points $H^1G^1F^1$ and repeat in the other sections of the development.

18.8H Developing a Square Base to a Circular Top

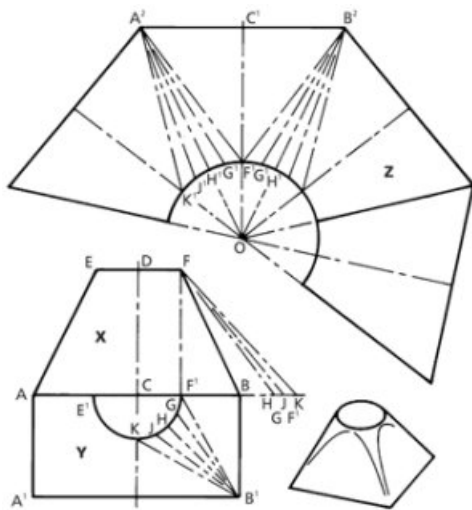

Draw the elevation X , making the base AB , vertical height CD , and diameter of top EF .

Draw a half plan Y on the base, drawing the semicircle E^1F^1 and dividing one half of this into a number of equal parts, F^1G , GH , HJ , and JK .

Through points F^1 , G , H , J , and K , draw lines to B^1 .

Before proceeding to the development it is necessary to find the true lengths of B^1K , B^1J , B^1H , B^1G , and B^1F^1 .

19

Revision History

Policy for Updates to NZ Metal Roof and Wall Cladding Code Practice.

All revisions to clauses of the COP after June 2018 are recorded at [19 Revision History](#), including a brief explanation of the change.

See sub-clauses for detail of revisions at particular dates.

Revisions are split into 3 categories for simple assessment by users:

19A Revision Categories

Category	Description	Notification
Category 1 - Minor Errata	Correction to spelling, grammar or formatting that have no bearing on on the substance of the clause.	Recorded on website only - not individually included in emailed update
Category 2 - Editing and rearrangement	A clause or section of clauses has been rewritten to some extent for better articulation of the existing recommendation. Existing citations of the COP in project documentation may be less clear as a result, but recommendations are not altered.	Recorded on website, and will be cited in emailed update as either specific or summary information as appropriate.
Category 3 - Substantial change to recommendation	A substantial change in a specific recommendation of the COP has taken place. A review of existing project documentation against the new clause is considered essential.	Recorded on website, and explained with detail in emailed update

19.1 2023 – September

The following revisions to the NZ Metal Roof and Wall Cladding Code of Practice were published on 1 September 2023.

Versioning and presentation:

- Beginning with this revision the Code of Practice updates its version number with each update, to make it clear when the current update was published.
The version numbering uses a year.month pattern: for example this update is v23.09, where 23 indicates the year (2023) and 09 indicates the month (September).
Refer to [19 Revision History](#) for a log of specific changes in each update.
- An overall upgrade to styling for improved typeface readability and better contrast in headings.
- Additionally there are new "Quick Actions" on the COP Home page for reference to updates and interactive tools, and the registration process has been streamlined.

Substantial change to recommendations:

- [16 Maintenance](#) and all its sub-clauses have been comprehensively revised.
- [5.6.2 Sumps](#): Added recommendation to seal internal sumps against the sides and soles of the gutter.
- [14.19.3 Correctly Installed Gutters](#): Changed recommendation for gutter drainage to be more consistent with MBIE tolerances.
- In [3 Structure](#), tables and graphs have been rearranged to correspond to whether the design is under NZS3604 or AS/NZS1170:
 - [3.10 Fastening Pattern Tables – Designs to NZS 3604](#)
 - [3.11 Wind Load/Span Graphs – Designs to AS/NZS1170](#)

Editing and rearrangement:

- [8.5.4 Apron Flashings](#): Corrected name for chase and face fastened flashing to *Reglet flashings*. Added definition to the *Glossary*.
- [9.4.2.6 Sheetmetal Flashings on Trapezoidal Profiles](#): Clarified recommendations for trapezoidal sheet cover above the flashing when using under-soaker flashings.
- Revised the Introduction to [3 Structure](#) to make it easier for users to find the correct fastening pattern for NZS3604 or Wind Load/Span Graphs for SED (AS/NZS 1170) designs.
- [3.9 Fastener Requirements and Overhangs](#): renamed the clause.
- [4.9.4 Compatibility Table](#): Correction to use caution for contact between concrete and steel.
- Revised [8.2A Notched Flashing](#) illustration to recommend a screw fastener to the purlin in preference to a rivet.
- [7.3.2B Unfavourable Circumstances for Controlling Expansion](#): inserted vertical axis label: sheet length (m). Removed Pan Fixing as unfavourable condition for expansion control.
- [15.4.8 Standing Seam Roofing Wind Loads](#): Renamed table – Generic Standing Seam Clip Spacing.
- [12.2 Purlin Creasing](#): Copy editing for clarity.
- [8.2.1 Flashing Edges](#): Removed recommendation to provide longitudinal flashings with an anti-capillary gap, as this is impractical.

The rest of the updates consisted of minor corrections and edits.

19.1A Revision Detail - 2023 - September

Category	Clause Number (prior to update)	Clause (As of current publication)	Details
2 - Editing and rearrangement	1	1 Introduction	Updated Revisions Message
2 - Editing and rearrangement	1.1	1.1 Disclaimer and Copyright	Removed copy explaining the update-policy and created a new subclause for those explanations.
4 - Clause Inserted		1.1.1 Code of Practice Update-Policy	Outline the update policy, new Version numbering scheme, and process for requesting archival content
2 - Editing and rearrangement	2.1	2.1 Definitions	Added definition for Reglet flashing.
4 - Clause Inserted		3.11 Wind Load/Span Graphs – Designs to AS/NZS1170	New clause to group 3.11.1 Steel Cladding Wind Load Span Graphs and 3.11.2 Aluminium Cladding Wind Load Span Graphs for designs to AS/NZS 1170.
2 - Editing and rearrangement	3	3 Structure	Revision of the introductory clause to clarify uses of 3.10 Fastening Pattern Tables – Designs to NZS 3604 and 3.11 Wind Load/Span Graphs – Designs to AS/NZS1170 .
1 - Minor Errata	3.2.1	3.2.1 AS/AZS 1170.2:2011	Fixed typo: amendments. Completed the last sentence and formatted the link to 3.7 Modes of Failure properly.
1 - Minor Errata	3.6.2.1	3.6.2.1 Wind Load	Resized photographs so they display the same.
1 - Minor Errata	3.6.2.2	3.6.2.2 Snow Loads	Grammatical fix for clarity.
1 - Minor Errata	3.7.2	3.7.2 Deflection	Fixed typo: distributed and roofing.
2 - Editing and rearrangement	3.9	3.9 Fastener Requirements and Overhangs	Clause has been renamed.
4 - Clause Inserted		3.10 Fastening Pattern Tables – Designs to NZS 3604	New clause to group 3.10.1 G550 Steel Cladding Fastening Pattern Tables and 3.10.2 Aluminium Fastening Pattern Tables for NZS3604-designs.
3 - Substantial change to recommendation	4.9.4	4.9.4 Compatibility Table	Correction to "use with caution" for contact between concrete and steel. Removed brand names in favour of generic descriptive terms.
4 - Clause Inserted	4.15.1	4.15.1 Ground Clearance	New clause under 4.15 Clearances .
3 - Substantial change to recommendation	5.5.7	5.5.7 Valley Capacity Calculator	Enabled valley calculations for roofs at pitches below 3° - enforces a minimum freeboard of 30mm

Category	Clause Number (prior to update)	Clause (As of current publication)	Details
3 - Substantial change to recommendation	5.6.2	5.6.2 Sumps	Added recommendation for internal sumps to be sealed against the sides and sole of the gutter. Some typo fixes.
1 - Minor Errata	6.2	6.2 Compliance	Fixed a missing link to: 7 External Moisture Roofing , 8 External Moisture Flashings , and 9 External Moisture Penetrations .
2 - Editing and rearrangement	8.2	8.2 Flashing Design	Revised 8.2A Notched Flashing illustration to recommend a screw fastener to the purlin in preference to a rivet.
2 - Editing and rearrangement	8.2.1	8.2.1 Flashing Edges	Removed recommendation to provide longitudinal flashings with an anti-capillary gap, as this is impractical.
4 - Clause Inserted		8.3 Metal Fascias and Facades	A new clause providing guidance for purpose-made Metal Fascias and Facades.
2 - Editing and rearrangement	8.4.4	8.5.4 Apron Flashings	Corrected name for 8.5.4H Parapet – Reglet Flashing, Chase Cut and 8.5.4I Parapet – Reglet Flashing, Face Fixed .
2 - Editing and rearrangement	9.4.2.6	9.4.2.6 Sheetmetal Flashings on Trapezoidal Profiles	Clarifying text for fixing under-soaker flashing added to 9.4.2.6B Level Under-Soaker: Trapezoidal ,
1 - Minor Errata	12	12 Fitness For Purpose	Fixed typo: Addition
1 - Minor Errata	13.3	13.3 Working on Roofs	Edited the caption under 13.3A Working on Roofs Safety Systems .
1 - Minor Errata	14.3	14.3 Accepting Delivery	Added clarifying statement to contact the supplier when the condition of the product is in doubt.
1 - Minor Errata	14.13.1	14.13.1 Nails	Photo of Nail Pull-Out rotated.
3 - Substantial change to recommendation	14.19.3	14.19.3 Correctly Installed Gutters	Changed recommendation for gutter drainage to be more consistent with MBIE tolerances.
1 - Minor Errata	15.1.1	15.1.1 Spring Curving	Updated reference to the tables in this clause.
1 - Minor Errata	15.1.6	15.1.6 Concave Roofs	Removed reference to a redundant table. Some grammar fixes.
1 - Minor Errata	15.1.9	15.1.9 Crimp Curving	Fixed a broken link to 16.8 Overpainting .
2 - Editing and rearrangement	15.4.8	15.4.8 Standing Seam Roofing Wind Loads	Renamed table, it is now called: Generic Standing Seam Clip Spacing and inserted Medium Wind Zone.
1 - Minor Errata	15.4.12.4	15.4.12.4 Finishing at Ridges and Eaves of Tray Roofing	Typo fix.

Category	Clause Number	Clause (As of current publication) (prior to update)	Details
1 - Minor Errata	16	16 Maintenance	Some editing for accuracy.
4 - Clause Inserted		16.1 Maintenance Compliance	New clause inserted.
0 - Clause Removed	16.1	Improved Durability	Clause removed during the over-all revision of 16 Maintenance .
0 - Clause Removed	16.2	Normal Maintenance	This clause was removed during the over-all revision of 16 Maintenance
4 - Clause Inserted		16.3 Reactive Maintenance	New clause created during the over-all revision of 16 Maintenance .
3 - Substantial change to recommendation	16.3	16.4 Scheduled Maintenance	The clause was revised as part of the overall revision of 16 Maintenance .
3 - Substantial change to recommendation	16.4	16.5 Preventative Maintenance	This clause was revised during the overall revision of 16 Maintenance .
3 - Substantial change to recommendation	16.5	16.6 Special Maintenance	This clause was revised during the overall revision of 16 Maintenance .
3 - Substantial change to recommendation	16.6	16.2 Inspection	Clause revised as part of the over-all revision of 16 Maintenance .
3 - Substantial change to recommendation	16.7	16.7 Washing	This clause was revised during the overall revision of 16 Maintenance .
3 - Substantial change to recommendation	16.7.1	16.7.1 Lichen And Mould	This clause was revised during the overall revision of 16 Maintenance .
2 - Editing and rearrangement	16.7.2	16.7.2 Graffiti	This clause was revised during the overall revision of 16 Maintenance .
3 - Substantial change to recommendation	16.8	16.8 Overpainting	This clause was revised during the overall revision of 16 Maintenance .
4 - Clause Inserted		16.8.1 Preparation for Overpainting	New clause created during the overall revision of 16.8 Overpainting .
3 - Substantial change to recommendation	16.8.1	16.8.3 Unpainted Cladding	This clause has been revised during the overall revision of 16 Maintenance .
2 - Editing and rearrangement	16.8.2	16.8.4 Weathered Pre-Painted Cladding	This clause was revised during the overall revision of 16 Maintenance .
2 - Editing and rearrangement	16.8.3	16.8.1.1 White Corrosion	This clause has been revised during the overall revision of 16 Maintenance .
2 - Editing and rearrangement	16.8.4	16.8.1.2 Red Corrosion	This clause was revised during the overall revision of 16 Maintenance .

Category	Clause Number	Clause (As of current publication) (prior to update)	Details
4 - Clause Inserted		16.8.5 Unweathered Pre-Painted Cladding	New clause created during the overall revision of 16 Maintenance .
3 - Substantial change to recommendation	16.8.5	16.8.2 Application	This clause has been renamed and completely revised during the overall revision of 16 Maintenance , previously independent clauses have also been incorporated. They are: Brush Application, Roller Application, Spray Application
0 - Clause Removed	16.8.6	Brush Application	This clause has been removed during the overall revision of 16 Maintenance . Brush Application is now discussed in 16.8.2 Application .
0 - Clause Removed	16.8.7	Roller Application	This clause has been removed during the overall revision of 16 Maintenance . Roller Application is now discussed in 16.8.2 Application .
0 - Clause Removed	16.8.8	Spray Application	This clause has been removed during the overall revision of 16 Maintenance . Spray Application is now discussed in 16.8.2 Application .
0 - Clause Removed	16.9	Material Selection	This clause was removed during an overall revision of 16 Maintenance .
0 - Clause Removed	16.9.1	Residential	This clause was removed during an overall revision of 16 Maintenance .
0 - Clause Removed	16.9.2	Commercial	This clause was removed during an overall revision of 16 Maintenance .
0 - Clause Removed	16.9.3	Responsibility and Liability	This clause was removed during an overall revision of 16 Maintenance .
0 - Clause Removed	16.9.4	Special Environments And Exclusions	This clause was removed during an overall revision of 16 Maintenance .
0 - Clause Removed	16.11	Storage	This clause was removed during an overall revision of 16 Maintenance . Storage is dealt with through various clauses under 14 Installation .
2 - Editing and rearrangement	18.2	18.2 Pitch & Rise Calculator	Renamed from "Roof Pitch Tangent" to "Pitch & Rise Calculator" for clarity.
2 - Editing and rearrangement	18.5	18.5 Geometry And Measurement	Renamed from "Geometry And Mensuration" to "Geometry And Measurement".
4 - Clause Inserted		19.1 2023 – September	New clause listing revisions for September 2023.

19.2 2023 – June

The following revisions to the NZ Metal Roof and Wall Cladding Code of Practice were published on 1 June 2023.

Substantial change to recommendations:

The main section **3 Structure** has been comprehensively revised.

- The revision comprises several changes throughout the main clause and sub-clauses.
- Several clauses were revised in part or completely and illustrations were updated.
- Clauses dealing with fastening patterns and SED Wind Load/Span Graphs are currently being reviewed pending ongoing MRM testing.
- An interactive filter for fastener patterns and load/span graphs is now available in these clauses.

Design	Steel	Aluminium
NZS 3604	3.10.1 G550 Steel Cladding Fastening Pattern Tables	3.10.2 Aluminium Fastening Pattern Tables
SED	3.11.1 Steel Cladding Wind Load Span Graphs	3.11.2 Aluminium Cladding Wind Load Span Graphs

Other important updates:

- A new clause discusses [12.3 Flashing Buckling](#) in more detail, while the old clause has been renamed Compression Timber.
- *Standing Seam Cladding* has been renamed [15.4 Tray Roofing](#) and the entire clause and its sub-clauses have been reviewed.
- The definition of *standing seam* roofing (a form of tray roofing installed on solid sarking, using traditional seaming tools) has been clarified.

The rest of the updates consisted of minor corrections and edits.

19.2B Revision Detail - 2023 - June

Category	Clause Number	Clause (As of current publication) (at time of update)	Details
2 - Editing and rearrangement	1	1 Introduction	Updated Revisions Message
2 - Editing and rearrangement	2.1	2.1 Definitions	Clarified the definition of <i>Standing Seam Profile</i> .
3 - Substantial change to recommendation	3	3 Structure	The main clause Structure has been comprehensively revised. The revision comprises several changes throughout the main clause and sub-clauses
4 - Clause Inserted		3.2 Standards	New clause to group the standards referred to in 3 Structure in the COP.

Category	Clause Number	Clause (As of current publication) (at time of update)	Details
0 - Clause Removed	3.2	General	This clause has been merged with the introductory clause for 3 Structure .
3 - Substantial change to recommendation	3.3	3.2.1 AS/AZS 1170.2:2011	This clause has been revised as part of the overall revision of 3 Structure .
3 - Substantial change to recommendation	3.4	3.2.2 NZS 3604:2011	Changed the description of what NZS 3604 includes. Removed the statement that NZS 3604 is location specific.
4 - Clause Inserted		3.2.3 NASH Standard	New clause to mention the NASH Standard in relation to B1/AS1.
4 - Clause Inserted		3.3 Performance	New clause. This clause was filled with information previously available in the old clause 3.5.1 Understanding Loads
4 - Clause Inserted		3.3.1 Section Properties	New sub-clause discussing how to determine profile strength under load.
3 - Substantial change to recommendation	3.15	3.4 Profiles	This clause has been revised as part of the overall revision of 3 Structure . Some copy has been moved to 3.5.6 Section Properties
2 - Editing and rearrangement	3.15.1	3.4.1 Corrugate Profile	The clause has been revised as part of the overall revision of Structure.
2 - Editing and rearrangement	3.15.2	3.4.2 Trapezoidal Profile	revised as part of the overall revision of 3 Structure .
3 - Substantial change to recommendation	3.15.5	3.4.3 Miniature Profiles	Deleted reference to metrical or imperial sizing of miniture profiles.
3 - Substantial change to recommendation	3.15.3	3.4.4 Secret-fixed Profiles	Clause renamed and combined with 3.15.4 Standing Seam (removed). Added an illustration
3 - Substantial change to recommendation	3.13	3.4.5 Material Grade	Content had been revised and edited as part of the overall revision of 3 Structure .
3 - Substantial change to recommendation	3.14	3.4.6 Material Thickness	The content of this clause was revised as part of the overall revision of 3 Structure .
4 - Clause Inserted		3.5 Loads	New introductory clause leading into various clauses dealing with different loads.

Category	Clause Number	Clause (As of current publication) (at time of update)	Details
3 - Substantial change to recommendation	3.5	3.5.1 Understanding Loads	The clause has been revised and edited as part of the overall revision of 3 Structure . The illustration of 3.3A Profiled Steel – Flanges and Webs and some content have been moved to 3.4 Profiles . The illustration 3.5.1A Compression, Tensile and Shear Force
0 - Clause Removed	3.5.1	Point Load	This clause has been removed as part of the overall revision of 3 Structure . Instead of two clauses
0 - Clause Removed	3.5.6	Section Properties	This clause was removed as part of the overall revision of 3 Structure . The information previous contained in this clause has been spread throughout other clauses.
3 - Substantial change to recommendation	3.5.8	3.5.1.1 Continuity	The content of this clause was revised and edited as part of the overall revision of 3 Structure . The illustration for 3.5.1.1A Continuity
2 - Editing and rearrangement	3.5.4	3.5.1.2 Load Distribution	The 3.5.1.2 Load Distribution -clause has been revised and edited as part of the overall revision of 3 Structure .
0 - Clause Removed	3.5.2	Wind Load	This clause was merged with 3.6.2.1 Wind Load as part of the overall revision of 3 Structure .
0 - Clause Removed	3.5.5	Yield Strength	This clause has been assimilated into a new clause
3 - Substantial change to recommendation	3.6	3.6 Types of Load	Clauses describing types of load have been rearranged and revised for clarity and easy of use. Content previously contained to this clause was distributed among it's sub-clauses.
2 - Editing and rearrangement	3.6.1	3.6.1 Point Load	This clause revised as part of the overall revision of 3 Structure .
3 - Substantial change to recommendation	3.7	3.6.2.1 Wind Load	Two clauses that previously discussed wind load were merged into one as part of the overall revision of 3 Structure . The content of both clauses were revised and edited to facilitate the merger.
3 - Substantial change to recommendation	3.7.1	3.6.2.1.1 Local Pressure Factor (Kl)	Corrected illustration 3.6.2.1.1A Local Pressure for Low-Pitch Roofs and deleted C Local Pressure Factors C .

Category	Clause Number	Clause (As of current publication) (at time of update)	Details
2 - Editing and rearrangement	3.7.2	3.6.2.1.2 Conversion of Wind Speed To Pressure	The content of this clause has been edited as part of a overall revision of 3 Structure .
2 - Editing and rearrangement	3.8	3.6.2.2 Snow Loads	This contents in this clause has been edited for conciseness as part of the overall revision of 3 Structure .
2 - Editing and rearrangement	3.7.3	3.6.2.3 Roof Weight	The content os this clause has been edited for clarity.
3 - Substantial change to recommendation	3.3.1	3.7 Modes of Failure	The contents of this clause has been edited as part of the overall revision of 3 Structure .
4 - Clause Inserted		3.7.1 Serviceability and Ultimate Failure	Newly created clause discussing <i>Serviceability and Ultimate Failure</i> .
3 - Substantial change to recommendation	3.5.3	3.7.2 Deflection	The content of this clause has been revised as part of the overall revision of 3 Structure . The contents have been merged with 3.5.5 Yield Strength
4 - Clause Inserted		3.7.3 Deformation	New clause made up of merged content from 3.7.2 Deflection and 3.5.5 Yield Strength .
3 - Substantial change to recommendation	3.6.2	3.7.4 Roof Traffic	The content of this has been edited to include a load of 2 kPa applied for accessible roofs.
3 - Substantial change to recommendation	3.9	3.7.5 Dead Loads	The content of this clause has been edited as part of the overall revision of 3 Structure .
2 - Editing and rearrangement	3.1	3.7.6 Construction Loads	The content is this clause has been revised as part of the overall revision of 3 Structure . A photo to illustrate rib damage due to construction loads was added.
3 - Substantial change to recommendation	3.5.7	3.7.7 Fatigue and Brittle Failure	The content of this clause has been revised as part of the overall revision of 3 Structure
4 - Clause Inserted		3.8 Fasteners	New introductory clause to sub-clauses dealing with structural requirements for fasteners.
3 - Substantial change to recommendation	3.11	3.8.1 Fastener Loads	The content is this clause has been revised as part of the overall revision of 3 Structure .
3 - Substantial change to recommendation	3.12.1.1	3.8.2 Steel Purlins	This clause has been renamed and merged with 3.12.1 Screw Fasteners and 3.12.1.2 Steel Purlins Thicker Than 1 mm .

Category	Clause Number (at time of update)	Clause (As of current publication)	Details
3 - Substantial change to recommendation	3.12.2	3.8.4 Pull-over Values	The content of this clause has been edited as part of the overall revision of 3 Structure . The copy was revised and the table A Typical Pull over values for crest fixing (serviceability failure) was removed.
2 - Editing and rearrangement	3.11.1	3.8.5 Load-spreading Washers	This clause has been moved as part of the overall revision of 3 Structure . It now follows 3.8.4 Pull-over Values .
0 - Clause Removed	3.12	Fastener Performance	This clause has been merged with 3.8.1 Fastener Loads .
0 - Clause Removed	3.12.1	Screw Fasteners	This clause has been merged with 3.8.2 Steel Purlins .
0 - Clause Removed	3.12.1.2	Steel Purlins Thicker Than 1 mm	This clause was merged with 3.8.2 Steel Purlins .
0 - Clause Removed	3.15.4	Standing Seam	Clause was combined with 3.4.4 Secret-fixed Profiles .
1 - Minor Errata	4	4 Durability	Fixed typo.
3 - Substantial change to recommendation	4.9.4	4.9.4 Compatibility Table	Correction to the combination of <i>Stainless Steel</i> with <i>Zinc or Zinc coated steel</i> , where runoff from <i>Stainless Steel</i> is not suitable. Amendment of some material descriptions to more common industry terms (<i>Galvanised steel</i> , <i>Colorsteel®/Colorcote®</i> , <i>Zincalume®</i>). Addition of <i>Painted Galvanised Steel</i> .
2 - Editing and rearrangement	5.5.1	5.5.1 Valley Fixing	Rearranged layout.
3 - Substantial change to recommendation	5.5.6	5.5.6 Asymmetrical Valleys	Added recommendation for valley baffles where roof pitches exceed 10°.
3 - Substantial change to recommendation	8.4.3	8.5.3 Parapet Cappings	This clause was comprehensively reviewed and all the illustrations were updated.
1 - Minor Errata	8.4.4	8.5.4 Apron Flashings	Edited for clarity. Removed mention of 'hidden flashings' and inserted mention of B2/AS1.
1 - Minor Errata	8.4.4.4	8.5.4.4 Eaves Flashing	The illustration of 8.5.4.4A Gutter-Eaves Flashing has been amended to align with measurements from E2/AS1.
2 - Editing and rearrangement	8.8	8.9 Compression Timber	Clause renamed. Flashing buckling is discussed in 12.3 Flashing Buckling .

Category	Clause Number	Clause (As of current publication) (at time of update)	Details
4 - Clause Inserted		12.3 Flashing Buckling	New clause discussing buckling of flashings.
1 - Minor Errata	14.11	14.11 Overhang	Drawing tidy up.
3 - Substantial change to recommendation	15.4	15.4 Tray Roofing	The entire clause 15.4 Tray Roofing
2 - Editing and rearrangement	15.4.1	15.4.1 Tray Profile Materials	Renamed the couse to <i>Tray Profile Materials</i> .
2 - Editing and rearrangement	15.4.2	15.4.2 Standing Seam Profiles	15.4 Tray Roofing has been revised and renamed to <i>Self-Support and Standing Seam Profiles</i> .
4 - Clause Inserted		15.4.3 Standing Seam Design	New clause discussing standing seam design.
3 - Substantial change to recommendation	15.4.3	15.4.4 Tray Fixings	<i>Standing Seam Fixings</i> has been reviewed
1 - Minor Errata	15.4.5	15.4.6 Sarking	Provided full terminology for CPD (Control Panel Directive).
2 - Editing and rearrangement	15.4.6	15.4.7 Tray Ventilation	<i>Standing Seam Ventilation</i> has been renamed <i>Tray Ventilation</i> .
2 - Editing and rearrangement	15.4.7	15.4.8 Standing Seam Roofing Wind Loads	The clause <i>Standing Seam Roofing Wind Loads</i> has been renamed <i>Tray Roofing Wind Loads</i> .
4 - Clause Inserted		15.4.8.1 Tray Roofing Wind Noise	New Clause for <i>Tray Roofing Wind Noise</i> .
2 - Editing and rearrangement	15.4.8	15.4.9 Penetrations on Tray Roofing	The clause <i>Penetrations on Standing Seam Cladding</i> has been renamed to <i>Penetrations on Tray Roofing</i> .
3 - Substantial change to recommendation	15.4.10.3	15.4.10 Tray Roof Flashing	1. Clause and illustraions have been renamed
2 - Editing and rearrangement	15.4.9	15.4.11 Canning and Purlin Creasing	Removed last line to avoid confusion .
2 - Editing and rearrangement	15.4.10	15.4.12 Installing Tray Cladding	Clause renamed
4 - Clause Inserted		15.4.12.2 Commence Laying Tray Cladding	New clause discussing laying of tray cladding.
2 - Editing and rearrangement	15.4.10.2	15.4.12.3 Provision for Expansion – Tray Roofing	Photo from <i>Installing Standing Seam Cladding</i> has been moved to 15.4.12.3 Provision for Expansion – Tray Roofing . Clause has been renamed for consistency.

Category	Clause Number	Clause (As of current publication) (at time of update)	Details
4 - Clause Inserted		15.4.12.4 Finishing at Ridges and Eaves of Tray Roofing	New clause describing tray roofing sheet end treatment.
1 - Minor Errata	17.1.5.1	17.1.5.1 Allowance for Variation	Corrected depreciation factor for clip-fastened products from 30% to 1.3.
4 - Clause Inserted		19.2 2023 – June	New clause with revision details for 1 June 2023.

19.3 2023 – March

The following revisions to the NZ Metal Roof and Wall Cladding Code of Practice were published on 1 March 2023.

Substantial changes to recommendations:

- **5.4.7 Gutter Capacity Calculator** extended to include secret gutters, and gutter fall greater than 1:100.
- New clause **5.2A Roof Drainage Terminology as used in the COP**.
- Opinion on small sheds and bay windows that do not require spouting.
- Reviewed table **7.1.1 Minimum Roof Cladding Pitch** and added maximum run.
- Added design advice for scuppers in **5.4.5.1 Internal Gutter Design Features**
- Added advice for minimising roof noise in **15.4.8 Standing Seam Roofing Wind Loads**.

Editing and rearrangement:

- Freeboard for Internal Gutters has been increased to 30mm to align with COP calculator and E1/AS1
- **14.11A Minimum Overhang** updated drawing. No change to recommendations.
- **14.17 Turndowns (Drip Forming or Drip Edging)** reviewed copy to provide guidance for difficult-to-turn-down profiles, such as deep corrugated profiles.
- **2 Glossary** added definitions for freeboard, internal gutters, hidden gutters, secret gutters, and raked spouting.
- Updated illustrations detailing
8.5.2C Stepped Fascia Corrugate Over Barge, 8.5.2B Stepped Fascia Corrugate Under Barge, 8.5.2E Stepped Fascia Trapezoidal Over Barge, 8.5.2D Stepped Fascia Trapezoidal Under Barge, 8.5.4H Parapet – Reglet Flashing, Chase Cut, 8.5.4I Parapet – Reglet Flashing, Face Fixed, 8.5.2F Tray Roofing-Wall Connection and 5.5.6A Valley Baffle.

Other changes consisted of small fixes for clarity and grammar.

19.3A Revision Detail - 2023 - March

Category	Clause Number	Clause (As of current publication)	Details
3 - Substantial change to recommendation	5.3.7	5.4.7 Gutter Capacity Calculator	Gutter Capacity Calculator now supports calculation where gutter fall is greater than 1:100, and has an option for Secret Gutters (i.e. where a roof slopes towards a raking wall or barge).
3 - Substantial change to recommendation	7.1.1	7.1.1 Minimum Roof Cladding Pitch	Revised and renamed table 7.1.1A Minimum Pitch for Generic Metal Roofing .
4 - Clause Inserted		5.2 Roof Drainage Terminology	New clause to clarify COP usage of terminology pertaining to Roof Drainage.

Category	Clause Number	Clause (As of current publication) (at time of update)	Details
4 - Clause Inserted		5.3.2.1 Designing for Climate Change	Newly introduced clause, recommending NIWA's HIRDS-tool.
4 - Clause Inserted		5.4.1.1 Bay Windows	New clause discussing drainage for Bay Windows.
4 - Clause Inserted		5.4.1.2 Outbuildings	New clause to give guidance on roof drainage for outbuildings.
2 - Editing and rearrangement	1	1 Introduction	Updated Revisions Message
2 - Editing and rearrangement	2.1	2.1 Definitions	Added definitions for Freeboard, Internal gutter, Hidden gutter, Secret gutter, and Raking Spouting.
1 - Minor Errata	3.5.2	3.5.2 Wind Load	Fixed broken link.
2 - Editing and rearrangement	5.3.5.1	5.4.5.1 Internal Gutter Design Features	Added clarifying text regarding scuppers.
2 - Editing and rearrangement	5.4.6	5.5.6 Asymmetrical Valleys	Included details drawing for installing a .
2 - Editing and rearrangement	8.3	8.4 Flashing Cover	Added clarification of rib cover to 8.4K Apron Flashing Cover – Trapezoidal .
2 - Editing and rearrangement	8.4.2	8.5.2 Barge And Verges	Added illustrations showing details for: 8.5.2B Stepped Fascia Corrugate Under Barge ; 8.5.2C Stepped Fascia Corrugate Over Barge ; 8.5.2D Stepped Fascia Trapezoidal Under Barge ; 8.5.2E Stepped Fascia Trapezoidal Over Barge ; and 8.5.2F Tray Roofing-Wall Connection .
2 - Editing and rearrangement	8.4.4	8.5.4 Apron Flashings	Added illustration showing 8.5.4H Parapet – Reglet Flashing, Chase Cut and 8.5.4I Parapet – Reglet Flashing, Face Fixed .
1 - Minor Errata	14.16	14.16 Stop-ends	Minor edit for clarity.
2 - Editing and rearrangement	14.17	14.17 Turndowns (Drip Forming or Drip Edging)	Edited copy to provide guidance for difficult to turn down profiles, such as deep corrugated profiles.
4 - Clause Inserted		19.3 2023 – March	Revision and updates active 1 March 2023.

19.4 2022 – November

In a major update, effective 1 November 2022, the Clause 15.5 – previously 'Insulated Panels' – has been revised and extended.

The main clause has been renamed **15.5 Warm Roofs**, and it now includes sub-clauses dealing with **15.5.1 Insulated Panels** **15.5.2 Composite Systems** and **15.5.3 Spray-On Systems**.

Other notable updates include:

- Changed recommendations for **5.5.6 Asymmetrical Valleys**.
- Changed recommendations for **15.4.8 Standing Seam Roofing Wind Loads** to minimise wind noise.
- The performance requirements quoted from **5.1 NZBC: Clause E1 – Surface Water** has been expanded to better reflect the intent of NZBC E1 – Surface Water.
- The **3.6.2.2B Altitudes for Snow Loading Design** was renamed to remove ambiguity.
- Roofing products with adhered absorbent fleece were added to **10.10 Ventilation Pathways**.
- **15.4.10 Tray Roof Flashing** details added to **15.4 Tray Roofing**.

The rest of the updates consist of minor edits for clarity and layout.

19.4A Revision Detail - 2022 - November

Category	Clause Number	Clause (As of current publication) (at time of update)	Details
2 - Editing and rearrangement	1	1 Introduction	Updated Revisions Message
2 - Editing and rearrangement	3.8	3.6.2.2 Snow Loads	Table 3.6.2.2B Altitudes for Snow Loading Designn was renamed to remove ambiguity.
1 - Minor Errata	3.15	3.4 Profiles	Renamed Tray/Deck profiles to Standing Seam/Tray Profiles.
1 - Minor Errata	5.1	5.1 NZBC: Clause E1 – Surface Water	Expanded performance requirement in accordance with E1– Surface Water.
3 - Substantial change to recommendation	5.4.6	5.5.6 Asymmetrical Valleys	Changed recommendation in line with the most recent 5.5.7 Valley Capacity Calculator .
2 - Editing and rearrangement	10.1	10.10 Ventilation Pathways	Added fleece lined products.
1 - Minor Errata	12.1.1	12.1.1 Wind Noise	Added recommendation to reduce Underlay Flutter, by adding spray-on foam insulation.
2 - Editing and rearrangement	15.3.2	15.3.2 Valleys	Updated Reference to 5.5.7 Valley Capacity Calculator
2 - Editing and rearrangement	15.4.6	15.4.7 Tray Ventilation	Replaced 15.4.7A Standing Seam Ventilation with better quality image.

Category	Clause Number (at time of update)	Clause (As of current publication)	Details
3 - Substantial change to recommendation	15.4.7	15.4.8 Standing Seam Roofing Wind Loads	Change in recommendation.
4 - Clause Inserted		15.4.10 Tray Roof Flashing	Newly created clause.
3 - Substantial change to recommendation	15.5	15.5 Warm Roofs	The main clause Insulated Panels have been renamed Warm Roofs. In addition to insulated panels, the clause also features composite roofs and spray-on systems.
2 - Editing and rearrangement	15.5.1	15.5.1.1 Insulated Panel Manufacturing	The clause Design under Insulated Panels has been comprehensively reviewed and edited. It is now called Insulated Panel manufacturing. The rest of the content is available in smaller sub-clauses throughout the new clause 15.5.1 Insulated Panels .
4 - Clause Inserted		15.5.1 Insulated Panels	Newly created clause for Insulated Panels.
4 - Clause Inserted		15.5.1.2 Insulated Panel Composition	Newly created clause.
4 - Clause Inserted		15.5.1.3 Insulated Panel Face Profiles	Newly created clause.
4 - Clause Inserted		15.5.1.6 Insulation Panel Insulation Values	Newly created clause.
4 - Clause Inserted		15.5.1.8 Natural Lighting for Insulated Panels	Newly created clause.
4 - Clause Inserted		15.5.1.11 Insulated Panels Fitness for Purpose	Newly created clause.
4 - Clause Inserted		15.5.1.12 Insulated Panel Installation	Newly created clause.
4 - Clause Inserted		15.5.1.13 Insulated Panel Installation Safety	Newly created clause.
4 - Clause Inserted		15.5.1.15 Insulated Panel Penetrations	Newly created clause.
4 - Clause Inserted		15.5.1.17 Insulated Panel End Laps	Newly created clause.
2 - Editing and rearrangement	15.5.2	15.5.1.4 Insulated Panel Face Materials	The clause has been comprehensively reviewed and edited.
4 - Clause Inserted		15.5.2 Composite Systems	Newly created clause.

Category	Clause Number (at time of update)	Clause (As of current publication)	Details
4 - Clause Inserted		15.5.2.1 Composite Systems Composition	Newly created clause.
4 - Clause Inserted		15.5.2.2 Composite System Installation	Newly created clause.
2 - Editing and rearrangement	15.5.3	15.5.1.5 Insulated Panel Core Materials	The clause has been comprehensively reviewed and edited.
4 - Clause Inserted		15.5.3 Spray-On Systems	Newly created clause.
4 - Clause Inserted		15.5.3.1 Ventilation of Spray-on Systems	Newly created clause.
2 - Editing and rearrangement	15.5.4	15.5.1.7 Insulation Panel Structure	This clause has been comprehensively reviewed and edited.
2 - Editing and rearrangement	15.5.4.1	15.5.1.14 Insulated Panels Supporting Structure	The clause has been comprehensively reviewed and renamed.
0 - Clause Removed	15.5.5	Thermal	Clause was removed during the revision of Insulated Panels.
0 - Clause Removed	15.5.5.1	Fire	Clause was removed during a revision of Insulated Panels.
2 - Editing and rearrangement	15.5.6	15.5.1.10 Insulated Panels and Internal Moisture	This clause has been comprehensively reviewed and renamed.
2 - Editing and rearrangement	15.5.7	15.5.1.9 Insulated Panel Acoustics	This clause has been comprehensively reviewed and edited.
3 - Substantial change to recommendation	15.5.8	15.5.1.16 Fixing Insulated Panels	This clause has been comprehensively revised and renamed.
2 - Editing and rearrangement	15.5.9	15.5.1.18 Insulated Panel Flashings	This clause has been comprehensively revised and renamed.
2 - Editing and rearrangement	17.3	17.3 MRM Soft Edge Standard	Editing for clarity.
4 - Clause Inserted		19.4 2022 – November	Revision summary for the November 2022 update.

19.5 2022 – June

The following revisions to the NZ Metal Roof and Wall Cladding Code of Practice were published on 1 June 2022.

Revised clauses:

Clause [15.4 Tray Roofing](#) and all its sub-clauses were comprehensively revised for this update.

Change in recommendation:

- [3.10.2 Aluminium Fastening Pattern Tables](#): Corrected minimum depth of corrugated aluminium to 17 mm instead of 27 mm.
- Added H36 to the headings for correct identification and product selection.

The rest of the updates consisted of minor changes, grammar fixes, and minor edits to improve clarity.

19.5A Revision Detail - 2022 - June

Category	Clause Number (at time of update)	Clause (As of current publication)	Details
3 - Substantial change to recommendation	3.2	3.10.2 Aluminium Fastening Pattern Tables	Corrected minimum depth of corrugated aluminium to 17 mm instead of 27 mm. Added H36 to the headings for correct identification and product selection.
3 - Substantial change to recommendation	7.1.1	7.1.1 Minimum Roof Cladding Pitch	Added corrugated profiles with a height of more than 35 mm to 7.1.1A Minimum Pitch for Generic Metal Roofing .
3 - Substantial change to recommendation	8.3	8.4 Flashing Cover	Increased recommended cover for 8.4E Barge Flashing Cover – Trapezoidal and Secret Fixed and 8.4G Barge Flashing Cover – Corrugate Category C from 50 mm to 75 mm.
3 - Substantial change to recommendation	15.4	15.4 Tray Roofing	The entire clause 15.4 Tray Roofing , including all sub-clauses, had been revised.
3 - Substantial change to recommendation	15.4.3	15.4.1 Tray Profile Materials	This sub-clause has been entirely revised as part of the revision of the main clause 15.4 Tray Roofing .
4 - Clause Inserted		15.4.2 Standing Seam Profiles	New clause, inserted as part of a comprehensive revision of 15.4 Tray Roofing .
4 - Clause Inserted		15.4.4 Tray Fixings	New clause, inserted as part of a comprehensive revision of 15.4 Tray Roofing .

Category	Clause Number (at time of update)	Clause (As of current publication)	Details
4 - Clause Inserted		15.4.5 Standing Seam End Laps	New clause, added as part of the comprehensive revision of 15.4 Tray Roofing .
4 - Clause Inserted		15.4.6 Sarking	New clause, introduced as part of a comprehensive revision of 15.4 Tray Roofing .
4 - Clause Inserted		15.4.7 Tray Ventilation	New clause, introduced during a comprehensive review of 15.4 Tray Roofing .
4 - Clause Inserted		15.4.8 Standing Seam Roofing Wind Loads	New clause, introduced during comprehensive revision of 15.4 Tray Roofing .
4 - Clause Inserted		15.4.9 Penetrations on Tray Roofing	New clause, introduced during a comprehensive review of 15.4 Tray Roofing .
4 - Clause Inserted		15.4.11 Canning and Purlin Creasing	New clause, introduced as part of a comprehensive revision of 15.4 Tray Roofing .
4 - Clause Inserted		15.4.12 Installing Tray Cladding	New clause, introduced as part of a comprehensive revision of 15.4 Tray Roofing .
4 - Clause Inserted		15.4.12.1 Standing Seam Cladding Set Out	New clause, introduced a during a comprehensive revision of 15.4 Tray Roofing .
4 - Clause Inserted		15.4.12.3 Provision for Expansion – Tray Roofing	New clause, introduced during a comprehensive revision of 15.4 Tray Roofing .
4 - Clause Inserted	19.1	19.5 2022 – June	Revision message June – 2022.
2 - Editing and rearrangement	1	1 Introduction	Update Revisions Message
2 - Editing and rearrangement	3.18	3.10.1 G550 Steel Cladding Fastening Pattern Tables	Edited table headings for improved readability. Inserted a table explaining wind speed as per NZS 3604.
1 - Minor Errata	9.4.2.3	9.4.2.3 Cricket Back Curbs	Grammar fix. Rewrote the last sentence.
1 - Minor Errata	17.1.2.2.3	17.1.2.2.3 Number of Spans	Clarification.
0 - Clause Removed	15.4.1	Self-Supporting Cladding	Clause removed during a comprehensive revision of 15.4 Tray Roofing . The subject is now discussed through various new sub-clauses.

Category	Clause Number (at time of update)	Clause (As of current publication)	Details
0 - Clause Removed	15.4.2	Fully Supported Roof And Wall Cladding	Clause removed during a comprehensive revision of 15.4 Tray Roofing . For information about the subject, see 15.4.6 Sarking .
0 - Clause Removed	15.4.2.1	Types	Clause removed as part of the overall revision of 15.4 Tray Roofing .
0 - Clause Removed	15.4.2.2	Traditional Architectural Metal Panels	Clause removed as part of the overall revision of 15.4 Tray Roofing .
0 - Clause Removed	15.4.2.3	Long Length Strip Roof Cladding	Clause removed as part of the overall revision of 15.4 Tray Roofing .
0 - Clause Removed	15.4.2.4	Types Of Joints	Clause removed as part of the overall revision of 15.4 Tray Roofing .
0 - Clause Removed	15.4.2.5	Standing Seam	Clause removed as part of the overall revision of 15.4 Tray Roofing .
0 - Clause Removed	15.4.2.6	Angled Seam	Clause removed as part of the overall revision of 15.4 Tray Roofing .
0 - Clause Removed	15.4.2.7	Roll Cap	Clause removed as part of the overall revision of 15.4 Tray Roofing .
0 - Clause Removed	15.4.2.8	Transverse Laps	Clause removed as part of the overall revision of 15.4 Tray Roofing .
0 - Clause Removed	15.4.3.1	Copper	Clause removed as part of the overall revision of 15.4 Tray Roofing . For information about this material, see 4.16.5 Copper .
0 - Clause Removed	15.4.3.2	Zinc	Clause removed as part of the complete revision of 15.4 Tray Roofing . For information about this material see 4.16.4 Zinc .
0 - Clause Removed	15.4.3.3	Aluminium	Clause removed as part of the complete revision of 15.4 Tray Roofing . For information about this material see 4.16.3 Aluminium .
0 - Clause Removed	15.4.3.4	Stainless Steel	Clause removed as part of the complete revision of 15.4 Tray Roofing . Information about this material can be found at 4.16.2 Stainless Steel .
0 - Clause Removed	15.4.3.5	Coated Steel	Clause removed as part of the revision of 15.4 Tray Roofing , information about this product is still available in 4.16.1 Steel .
0 - Clause Removed	15.4.4	Loadings	Clause removed as part of the overall revision of 15.4 Tray Roofing .

Category	Clause Number	Clause (As of current publication) (at time of update)	Details
0 - Clause Removed	15.4.4.1	Fixing	Clause removed as part of the overall revision of 15.4 Tray Roofing .
0 - Clause Removed	15.4.4.2	Substrate	Clause removed as part of the overall revision of 15.4 Tray Roofing .
0 - Clause Removed	15.4.4.3	Fasteners	Clause removed as part of the overall revision of 15.4 Tray Roofing .
0 - Clause Removed	15.4.5	Underlay	Clause removed during a comprehensive revision of 15.4 Tray Roofing . Information about underlay can be found in 10.11 Underlay .
0 - Clause Removed	15.4.6	Ventilation	Clause removed during a comprehensive revision of 15.4 Tray Roofing . The subject is now discussed in 15.4.7 Tray Ventilation .
0 - Clause Removed	15.4.7	Drainage	Clause removed during a comprehensive revision of 15.4 Tray Roofing . For information about drainage, see 5 Roof Drainage .
0 - Clause Removed	15.4.7.1	Valleys	Clause removed as part of the overall revision of 15.4 Tray Roofing .
0 - Clause Removed	15.4.8	Facade Cladding	This clause was removed during a comprehensive revision of 15.4 Tray Roofing . The subject is now discussed through various other sub-clauses.
0 - Clause Removed	15.4.9	Edge Finishes	This clause was removed during a comprehensive revision of 15.4 Tray Roofing , please see the new sub-clause 15.4.5 Standing Seam End Laps .
0 - Clause Removed	15.4.9.1	Ridge And Hip	Clause removed as part of the overall revision of 15.4 Tray Roofing .
0 - Clause Removed	15.4.9.2	Apron Or Abutment	Clause removed as part of the overall revision of 15.4 Tray Roofing .
0 - Clause Removed	15.4.9.3	Eaves And Verge	Clause removed as part of the overall revision of 15.4 Tray Roofing .
0 - Clause Removed	15.4.9.4	Penetrations	Clause removed as part of the overall revision of 15.4 Tray Roofing .
0 - Clause Removed	15.4.9.5	Cappings	Clause removed as part of the overall revision of 15.4 Tray Roofing .
0 - Clause Removed	15.4.10	Durability	Clause removed during a comprehensive revision of 15.4 Tray Roofing . For durability issues, see 15.4.10 Durability .

Category	Clause Number	Clause (As of current publication)	Details
0 - Clause Removed	15.4.10.1	Patina Formation	Clause removed as part of the overall revision of 15.4 Tray Roofing .
0 - Clause Removed	15.4.10.2	Copper Patination	Clause removed as part of the overall revision of 15.4 Tray Roofing .
0 - Clause Removed	15.4.10.3	Zinc Patination	Clause removed as part of the overall revision of 15.4 Tray Roofing .

19.6 2022 – April

The following revisions to the NZ Metal Roof and Wall Cladding Code of Practice were published on 1 April 2022.

Change in recommendation:

4.9.1 Dissimilar Metals: Gutters and spouting made from materials which are incompatible with the roof cladding to include special provisions such as a gap between spouting and fascia, using leaf deflectors, and considering low fronted spouting.

Revised clauses:

- **8.4 Flashing Cover:** Revision of the minimum requirements for flashing cover in the Metal Roofing Code of Practice. Drawings have been updated and a *category C* added for SED Wind Zones up to 60 m/s on all pitches.
- **10.10 Ventilation Pathways** has completely revised for clarity. The revision includes a new recommendation to provide additional ventilation for trough or tray section roofs.

The rest of the updates consisted of minor changes, editing, and new drawings for **14 Installation**, without any changes in recommendations.

19.6A Revision Detail - 2022 - April

Category	Clause Number (at time of update)	Clause (As of current publication)	Details
3 - Substantial change to recommendation	4.9.1, 4.10.1	4.9.1 Dissimilar Metals	Change of recommendation for spouting and roof cladding made from incompatible material.
3 - Substantial change to recommendation	8.3	8.4 Flashing Cover	Clause has been completely revised.
3 - Substantial change to recommendation	10.1	10.10 Ventilation Pathways	Clause revised for clarity.
2 - Editing and rearrangement	1	1 Introduction	Update Revisions Message
1 - Minor Errata	2.1, 2.1	2.1 Definitions	Added definition for SED Wind Zone.
2 - Editing and rearrangement	3.15, 3.13	3.4 Profiles	Inserted new Drawing: Profile Types –
2 - Editing and rearrangement	5.3.7	5.4.7 Gutter Capacity Calculator	Enabled Profile Description Field to describe product.
1 - Minor Errata	5.4.7	5.5.7 Valley Capacity Calculator	Standardise internal structure - no user facing or operational changes.
1 - Minor Errata	5.6.3	5.7.3 Downpipe Capacity Calculator	Standardise internal structure - no user facing or operational changes.

Category	Clause Number (at time of update)	Clause (As of current publication)	Details
2 - Editing and rearrangement	5.7.1	5.8.1 Maximum Area Above Spreader Calculator	Enabled Profile Description Field to describe product.
2 - Editing and rearrangement	7.1.4	7.1.4 Maximum Run Calculator	Enabled Profile Description Field to describe product.
2 - Editing and rearrangement	8.3.2	8.2.1 Flashing Edges	Copy moved from 8.4 Flashing Cover to this clause.
4 - Clause Inserted		8.4.1 Apron Upstands	New clause created from 8.4 Flashing Cover .
4 - Clause Inserted		8.4.2 Clearances	New clause created from 8.4 Flashing Cover .
4 - Clause Inserted		8.4.3 Ridging and Other Transverse Flashings	New clause created from 8.4 Flashing Cover .
1 - Minor Errata	8.4.4.4	8.5.4.4 Eaves Flashing	Corrected reference typo E1/AS1 to E2/AS1.
2 - Editing and rearrangement	9.4.4	9.4.4 Maximum Area Above Penetration Calculator	Enabled Profile Description Field to describe product.
1 - Minor Errata	10.10.1.2	10.10.1.2 Fascia Vents	Grammar fix.
4 - Clause Inserted		10.10.1.4 Vented Soft Edge	New clause.
2 - Editing and rearrangement	10.10.1	10.10.1 Methods of Ventilation	Clause renamed.
1 - Minor Errata	10.10.2	10.10.2 Battens	Grammatical fix for clarity.
4 - Clause Inserted		10.10.3 Applied Fleeces	New Clause.
2 - Editing and rearrangement	14.13.2	14.13.2 Screws	Updated drawings: 14.13.2D Screw Gauge and 14.13.2E Threads per Inch (TPI) .
2 - Editing and rearrangement	14.16	14.16 Stop-ends	Drawings updated: 14.16A Dog-eared Stop-ends , 14.16B Pull-up Stopends , and 14.16C Corrugate Stop-ends .
2 - Editing and rearrangement	14.17	14.17 Turndowns (Drip Forming or Drip Edging)	Updated drawing: 14.17A Profile Turndown
2 - Editing and rearrangement	14.19.1	14.19.1 Roof Cladding Damage	Drawing updated: 14.19.1A Sealed and Riveted Saddle
2 - Editing and rearrangement	14.3.1	14.3.1 Unloading	Drawing updated: 14.3.1A Sling with Spreader Bar .
2 - Editing and rearrangement	14.6	14.6 Walking On Roofs	Drawings updated: 14.6A Walking in the Pan and 14.6B Spreading Weight over two Ribs .
4 - Clause Inserted		19.6 2022 – April	Revision message – April 2022.

19.7 2021 – December

The following revisions to the NZ Metal Roof and Wall Cladding Code of Practice were published on 1 December 2021.

Summary of Changes in this update:

- Update to **5A Capacity Calculations**: These have now all been updated to require input of both 10 and 50 year ARI. This allows the calculators to automatically incorporate the correct ARI for the specifics of the project. Both values are retained when you select a different calculator or return for another project.
- Complete revision of clause **12.1 Roof Noise**.
- Complete revision of clause **4.10.3 Solar Collectors and Other Roof Mounted Structures**.
- Change of recommendation for **3.10.1 G550 Steel Cladding Fastening Pattern Tables** in Extra High Wind Zones. Recommendation amended from C2 pattern to C3.

The rest of this update comprises minor edits and fixes.

19.7A Revision Detail - 2021 - December

Category	Clause Number (at time of update)	Clause (As of current publication)	Details
3 - Substantial change to recommendation	3.17.1	3.11.1.1 Corrugated Steel – 0.40	Drawing edited to change C2 recommendation to stay below Very High.
3 - Substantial change to recommendation	3.17.2	3.11.1.2 Corrugated Steel – 0.55	Changed recommendation for C2, to only be used below Very High Wind Zones.
3 - Substantial change to recommendation	4.10.3	4.10.3 Solar Collectors and Other Roof Mounted Structures	Clause has been completely revised.
3 - Substantial change to recommendation	8.8	8.9 Compression Timber	Changed recommended minimum moisture content to 12% following advice from Scion .
3 - Substantial change to recommendation	12.1	12.1 Roof Noise	This clause has been substantially revised. Some-subsections have been promoted to headings and some had been deleted a part of the revision.
4 - Clause Inserted		12.1.1 Wind Noise	New clause, raised and revised from former sub-sub clause of Roof Noise.
4 - Clause Inserted		12.1.2 Precipitation Noise	Newly created clause from the revised Roof Noise.
4 - Clause Inserted		12.1.3 Thermal Noise	New clause, information elevated from the revised Roof Noise.
4 - Clause Inserted		19.7 2021 – December	Revision message for the 1 December 2021 Update.

Category	Clause Number (at time of update)	Clause (As of current publication)	Details
2 - Editing and rearrangement	1	1 Introduction	Update Revisions Message
2 - Editing and rearrangement	5.3.7	5.4.7 Gutter Capacity Calculator	All calculators now require input of both 50 year and 10 year ARI.
2 - Editing and rearrangement	5.4.7	5.5.7 Valley Capacity Calculator	All calculators now require input of both 50 year and 10 year ARI.
2 - Editing and rearrangement	5.6.3	5.7.3 Downpipe Capacity Calculator	All calculators now require input of both 50 year and 10 year ARI.
2 - Editing and rearrangement	5.7.1	5.8.1 Maximum Area Above Spreader Calculator	All calculators now require input of both 50 year and 10 year ARI.
2 - Editing and rearrangement	7.1.4	7.1.4 Maximum Run Calculator	All calculators now require input of both 50 year and 10 year ARI.
2 - Editing and rearrangement	9.4.4	9.4.4 Maximum Area Above Penetration Calculator	All calculators now require input of both 50 year and 10 year ARI.
1 - Minor Errata	1.3	1.3 Standards and Related Documents	Fixed column spacing.
1 - Minor Errata	2.1	2.1 Definitions	Clarified definitions for tray, trough, standing seam, and secret fixed profiles.
1 - Minor Errata	3.6.2	3.7.4 Roof Traffic	Changed "trademan" to trades people for gender neutrality.
1 - Minor Errata	3.18	3.10.1 G550 Steel Cladding Fastening Pattern Tables	Fixed grammar for consistency. Fixed drawings to show C2 fastening pattern.
2 - Editing and rearrangement	4.6.2	4.6.2 Environmental Guides	Envrimental guides redone for improved display on all browsers.
1 - Minor Errata	15.1	15.1 Curved Roofs	Grammar fix.
1 - Minor Errata	16.8	16.8 Overpainting	slight formatting change for improved reading.

19.8 2021 – September

The following revisions to the NZ Metal Roof and Wall Cladding Code of Practice were published on 1 September 2021.

Summary of Changes in this update:

- In an important update, the recommendation for freeboard for internal gutters on the [5.4.7 Gutter Capacity Calculator](#) was changed to 30mm to align with E1/AS1 and E1/AS2.
- The recommendation for minimum suitable pitch for [9.1 Penetrations Minimum Pitch](#), has been amended to include modern proprietary profiles.
- New clauses with easy-to-use fastener pattern reference tables. The tables would cover most standard corrugated and trapezoidal cladding, for [3.10.1 G550 Steel Cladding Fastening Pattern Tables](#) and [3.10.2 Aluminium Fastening Pattern Tables](#).
- Other new clauses were for [5.5.4 Intersecting Valleys](#) and [14.8 Double Lapping](#).
- The drawing in [5.8 Downpipe Spreaders](#) was replaced to give a clearer reflection of the downpipe design and using the online downpipe spreader capacity calculator.

The rest of this update consisted of fixing minor errors.

19.8A Revision Detail - 2021 - September

Category	Clause Number (at time of update)	Clause (As of current publication)	Details
2 - Editing and rearrangement	1	Introduction	Update Revisions Message
4 - Clause Inserted		3.10.1 G550 Steel Cladding Fastening Pattern Tables	New clause aimed at easy reference of fastening patterns.
4 - Clause Inserted		3.10.2 Aluminium Fastening Pattern Tables	New clause for easy referencing of fastening patterns for aluminium cladding.
1 - Minor Errata		3.7.4 Roof Traffic	Changed "tradesman" to trades people for gender neutrality.
1 - Minor Errata		3.6.2 Uniformly Distributed Load (Wind or Induced Action)	Corrected spelling of "Uniformly. Included a full term before the abbreviation for UDL in the first sentence.
2 - Editing and rearrangement		5.4.3 Internal Corners	Clause moved from Valleys to Gutters.
3 - Substantial change to recommendation		5.4.7 Gutter Capacity Calculator	The minimum Freeboard on internal gutter calculations has been changed to 30mm to align with E1/AS1 and E1/AS2.
1 - Minor Errata		5.5.2 Valley Design	Inserted cross-reference link to Internal Corners.
4 - Clause Inserted		5.5.4 Intersecting Valleys	New clause showing the correct way to intersect valleys.
2 - Editing and rearrangement		5.8 Downpipe Spreaders	Replaced Downpipe Spreader Design-drawing with a more detailed one.
3 - Substantial change to recommendation		9.1 Penetrations Minimum Pitch	Revised first sentence to make allowance for modern profiles and proprietary profiles.
4 - Clause Inserted		14.8 Double Lapping	New clause.
4 - Clause Inserted		19.8 2021 – September	New Revision clause

19.9 2021 – June

The following updates to the NZ Metal Roof and Wall Cladding Code Practice (COP), are effective 1 June 2021.

COP Clauses [11 Natural Light](#) and [14 Installation](#) were comprehensively reviewed and revised for this update. Users are advised to reread those clauses for the most up-to-date information and recommendations.

Other updates included minor fixes to grammar, layout, and updated drawings and dividing [4.9.4 Compatibility Table](#) into smaller, more usable clauses (with no change to recommendations).

19.9A Revision Detail - 2021 - June

Category	Clause Number (at time of update)	Clause (As of current publication)	Details
2 - Editing and rearrangement	1	1 Introduction	Update Revisions Message
1 - Minor Errata	3.5.2	3.5.2 Wind Load	Some rewording for clarity.
1 - Minor Errata	4.10.1	4.9.1 Dissimilar Metals	Editing for clarity.
2 - Editing and rearrangement	4.10.3	4.9.4 Compatibility Table	The clause was split for ease of use.
3 - Substantial change to recommendation	5.2.2.2	5.3.2.3 Allowance for Short-Term Intensities	Updated Short-term Intensity Factor Explanation.
1 - Minor Errata	5.4.2	5.5.2 Valley Design	UPdated link to the Valley Capacity Calculator.
2 - Editing and rearrangement	8.4.4.4	8.5.4.4 Eaves Flashing	Inserted a paragraph recommending eaves flashings in Marine Environments.
2 - Editing and rearrangement	10.9	10.9 Minimising Ingress of Water Vapour into the Ceiling Cavity	Clause renamed and revised for clarity.
3 - Substantial change to recommendation	11	11 Natural Light	COP Clause 11. Natural Light has been completely revised.
3 - Substantial change to recommendation	11.1	11.1 Clause G7 NZBC	COP Clause 11. Natural Light has been entirle revised.
3 - Substantial change to recommendation	11.2	11.2 Natural Light Materials	COP clause 11. Natural Light has been revised, which includes the clause previously titled "Materials".

Category	Clause Number (at time of update)	Clause (As of current publication)	Details
0 - Clause Removed	11.3	Types Of Roof Lights	This clause was removed as part of an overall revision of COP clause 11. Natural Light. Illustration of different rooflights can be found in Thermal Expansion and
3 - Substantial change to recommendation	11.4	11.5 Light Transmission	Clause has been revised as part of an overall revision of COP Clause 11. Natural Light.
0 - Clause Removed	11.5	Weathering And Durability	This clause has been removed as part of an overall revision of COP Clause 11. Natural Light. Information about translucent sheeting durability can now be found at Natural Light Performance - Durability,
3 - Substantial change to recommendation	11.6	11.3 Performance – Structure	Clause renamed and content added.
2 - Editing and rearrangement	11.6.1	11.3.1 Point Load on Translucent Sheets	Clause revised and renamed as part of the overall revision of COP Clause 11. Natural Light.
2 - Editing and rearrangement	11.6.2	11.3.2 Distributed Loads on Translucent Sheeting	Clause revised and renamed as part of the overall revision of COP Clause 11. Natural Light.
3 - Substantial change to recommendation	11.7	11.4 Thermal Resistance	Clause has been revised as part of an overall revision of COP Clause 11. Natural Light.
3 - Substantial change to recommendation	14	14 Installation	COP Clause 14. Installation has been significantly reviewed and revised.
1 - Minor Errata	14.1	14.11 Overhang	Drawing tidy up.
3 - Substantial change to recommendation	14.1	14.1 Pre- Installation	This clause has been revised as part of an overall revision of COP Clause 14. Installation.
3 - Substantial change to recommendation	14.2.2	14.2.2 Ordering	This clause has been reviewed as part of a substantial revision of COP Clause 14. Installation.
3 - Substantial change to recommendation	14.2.3	14.2.3 Transportation	This clause has been reviewed as part of a substantial revision of COP Clause 14. Installation.
3 - Substantial change to recommendation	14.3	14.3 Accepting Delivery	This clause has been reviewed as part of a substantial revision of COP Clause 14. Installation.

Category	Clause Number (at time of update)	Clause (As of current publication)	Details
3 - Substantial change to recommendation	14.3.1	14.3.1 Unloading	This clause has been reviewed as part of a substantial revision of COP Clause 14. Installation.
3 - Substantial change to recommendation	14.3.2	14.3.2 Wet Storage Damage	This clause has been reviewed as part of a substantial revision of COP Clause 14. Installation.
3 - Substantial change to recommendation	14.6	14.6 Walking On Roofs	This clause has been reviewed as part of a substantial overall revision of COP Clause 14. Installation.
3 - Substantial change to recommendation	14.6.1	14.6.1 Footwear	This clause has been reviewed as part of a substantial revision of COP Clause 14. Installation.
3 - Substantial change to recommendation	14.7	14.7 Strippable Films	This clause has been reviewed as part of a substantial revision of COP Clause 14. Installation.
4 - Clause Inserted	14.7.1	14.7.1 Storing Product with Strippable Film	This clause has been removed as part of a substantial revision of COP Clause 14. Installation. For handling and storage of products with strippable film, please see Strippable Films.
0 - Clause Removed	14.7.2	Using Strippable Film	This clause has been removed as part of a substantial revision of COP Clause 14. Installation. For using and handling products with strippable film, please see Strippable Films.
1 - Minor Errata	14.9	14.10 Marking and Cutting	This clause has been reviewed as part of a substantial revision of COP Clause 14. Installation.
2 - Editing and rearrangement	14.12.2	14.13.2 Screws	Added "Reduced Diameter Drill Point" to Screw Points. This clause has been reviewed as part of a substantial revision of COP Clause 14. Installation.
1 - Minor Errata	14.12.3	14.13.3 Clip Fasteners	This clause has been reviewed as part of a substantial revision of COP Clause 14. Installation.
3 - Substantial change to recommendation	14.12.4	14.13.4 Rivets	This clause has been reviewed as part of a substantial revision of COP Clause 14. Installation.
1 - Minor Errata	14.13	14.14 Fastener Installation	This clause has been reviewed as part of a substantial revision of COP Clause 14. Installation.

Category	Clause Number (at time of update)	Clause (As of current publication)	Details
4 - Clause Inserted	14.15	14.16 Stop-ends	This clause has been reviewed as part of a substantial revision of COP Clause 14. Installation.
1 - Minor Errata	14.16	14.17 Turndowns (Drip Forming or Drip Edging)	This clause has been reviewed as part of a substantial revision of COP Clause 14. Installation.
1 - Minor Errata	14.18	14.19 Avoiding Problems	This clause has been renamed as part of an overall revision of COP Clause 14. Installation.
3 - Substantial change to recommendation	14.18.1	14.19.1 Roof Cladding Damage	This clause has been reviewed as part of a substantial revision of COP Clause 14. Installation.
3 - Substantial change to recommendation	14.18.2	14.19.2 Water Ponding	This clause has been reviewed as part of a substantial revision of COP Clause 14. Installation.
3 - Substantial change to recommendation	14.18.3	14.19.3 Correctly Installed Gutters	This clause has been reviewed as part of a substantial revision of COP Clause .
3 - Substantial change to recommendation	14.18.4	14.19.4 Swarf Damage	This clause has been reviewed as part of a substantial revision of COP Clause 14. Installation.
0 - Clause Removed	14.18.4.1	Identifying Swarf Stains	This clause has been removed as part of a substantial revision of COP Clause 14. Installation.
3 - Substantial change to recommendation	14.18.4.2	14.19.4.1 Preventing Swarf Damage	This clause has been reviewed as part of a substantial revision of COP Clause 14. Installation.
0 - Clause Removed	14.18.4.3	Swarf Effect on Performance	This clause has been reviewed as part of an overall revision of COP Clause 14. Installation. For more information about swarf effects, please read Swarf Staining and Cut Edge Corrosion.
0 - Clause Removed	14.18.4.4	Repairing Swarf Damage	This clause has been reviewed as part of an overall revision of COP Clause 14. Installation. For more information about dealing with swarf, see Swarf Damage.
2 - Editing and rearrangement	14.18.5	14.19.5 Colour Matching Paint	Inserted picture. This clause has been reviewed as part of an overall revision of COP Clause 14. Installation.

Category	Clause Number (at time of update)	Clause (As of current publication)	Details
2 - Editing and rearrangement	14.18.7	14.19.7 Sunscreen	Inserted photo of sunscreen damage. This clause has been reviewed as part of an overall revision of COP Clause 14. Installation.
0 - Clause Removed	14.18.8	Removing Lichen	This clause has been removed as part of an overall revision of COP Clause 14. Installation. For information about Lichen, see Lichen.
0 - Clause Removed	14.18.9	Gutter Installation	This clause has been removed as part of an overall revision of COP Clause 14. Installation. For Information about gutters, see Gutters.
1 - Minor Errata	14.19	14.20 Fixing Aluminium Sheeting	Grammar fix. This clause has been reviewed as part of an overall revision of COP Clause 14. Installation.
1 - Minor Errata	14.19.2	14.20.2 Recommendations for Fixing Aluminium	Fixed a link.
4 - Clause Inserted		11.8 Flatsheet Rooflights	New clause created as part of an overall revision of COP Clause 11. Natural Light.
4 - Clause Inserted		14.12.2 Side Laps	New clause created as part of a substantial revision of COP Clause 14. Installation.
4 - Clause Inserted		11.7 Stand-Alone Rooflights	New clause created as part of an overall revision of COP Clause 11. Natural Light.
4 - Clause Inserted		11.6 Installing Translucent Sheets	New clause under COP Clause 11. Natural Light.
4 - Clause Inserted		Natural Light Performance - Durability	New clause.
4 - Clause Inserted		11.1.1 Compliance	New clause dealing with natural light and compliance to NZBC G7.
4 - Clause Inserted		19.9 2021 – June	Revision message for the update on 1 June 2021.

19.10 2021 – March

The addition of an interactive calculator for asymmetrical valleys constitutes the most important inclusion in this update.

The other capacity calculators have all been refined and positioned for improved usability.

19.10A Capacity Calculators

Gutter Capacity	5.4.7 Gutter Capacity Calculator
Valley Capacity (both symmetrical and asymmetrical)	5.5.7 Valley Capacity Calculator
Downpipe Capacity	5.7.3 Downpipe Capacity Calculator
Maximum Area Above Spreaders	5.8.1 Maximum Area Above Spreader Calculator
Maximum Area Above Penetrations	9.4.4 Maximum Area Above Penetration Calculator
Maximum Run	7.1.4 Maximum Run Calculator

In addition, various drawings have been updated for accuracy and correctness.

The rest of this update consisted of fixing minor errors and improvements for clarity.

19.10B Revision Detail - 2021 - March

Category	Clause Number (at time of update)	Clause (As of current publication)	Details
2 - Editing and rearrangement	1	1 Introduction	Update Revisions Message
1 - Minor Errata	2.1	2.1 Definitions	Added definitions for Translucent, Transparent, Opalescent, and Opaque.
1 - Minor Errata	3.13	3.4.5 Material Grade	Minor revision for Aluminium.
0 - Clause Removed	4.8	Biological Corrosion	Clause removed. 4.8.4 Lichen is now in 4.8 Paint Durability , and 4.10.9 Gutter Leaf Guard is now in 4.10 Other Causes of Corrosion .
2 - Editing and rearrangement	5.3.7	5.5.7 Valley Capacity Calculator	Updated calculator to support Asymmetrical Valley calculations, including dynamic illustration.

Category	Clause Number (at time of update)	Clause (As of current publication)	Details
2 - Editing and rearrangement	5.5.2	5.8.1 Maximum Area Above Spreader Calculator	Clause edited, new clause (Downpipe Spreaders) introduced with explanatory text about spreaders. Trapezoidal illustration updated to show effective pan-depth area.
2 - Editing and rearrangement	5.6	5.4.2 Gutter Capacity Design	Clause renamed and moved to Types of Gutter.
1 - Minor Errata	5.6.2	5.4.2.3 Gutter Support Systems	Clause moved to Gutter Installation and Maintenance.
2 - Editing and rearrangement	5.6.3	14.18.9 Gutter Installation	Clause renamed and moved to Pre-empting Problems.
2 - Editing and rearrangement	5.7.1	5.8 Downpipe Spreaders	Previously removed clause, now reinstated and updated to align with the new Maximum Area Above Spreader Calculator.
1 - Minor Errata	5.7.2	5.4.2.1 Gutter Fall	Clause moved to Gutter Installation and Maintenance.
2 - Editing and rearrangement	5.7.5	5.7.3 Downpipe Capacity Calculator	Illustration updated to show effective head.
2 - Editing and rearrangement	5.8	5.4.7 Gutter Capacity Calculator	Rectangular Gutter illustration updated to show effective gutter area. Clause renamed to refine search results.
0 - Clause Removed	6.2	Acceptable Solution NZBC E2/AS1	Clause removed as it pertains to E2, which is discussed in NZBC Clause E2 External Moisture (Extract).
2 - Editing and rearrangement	6.2.1	6.2 Compliance	Clause promoted, replacing ES/AS1 at position 6.2, and content of clause reviewed.
2 - Editing and rearrangement	7.1.4	7.1.4 Maximum Run Calculator	Trapezoidal illustration updated to show effective pan-depth area.
2 - Editing and rearrangement	7.4	7.4 End Laps	Drawing deleted, replaced with a reference to 14.12.1 Sealing End Laps .
2 - Editing and rearrangement	8.7	8.8 Profile Closures	Clause revised. Recommendations have not changed. Drawings replaced with more accurate depictions.
2 - Editing and rearrangement	9.4.4	9.4.4 Maximum Area Above Penetration Calculator	Trapezoidal illustration updated to show effective pan-depth area.
2 - Editing and rearrangement	14.11.1	14.12.1 Sealing End Laps	Drawing replaced with with more accurate depiction of correctly and incorrectly sealed end laps.
1 - Minor Errata	15.4.4.2	15.4.4.2 Substrate	Removed empty link.

Category	Clause Number (at time of update)	Clause (As of current publication)	Details
4 - Clause Inserted		19.10 2021 – March	New Revision clause.

19.11 2020 – December

The following revisions to the NZ Metal Roof and Wall Cladding Code of Practice were published on 1 December 2020.

Summary of Changes in this update:

We introduced three more responsive tools to aid in roof drainage design. They are:

- **7.1.4 Maximum Run Calculator:** Calculating the maximum roof length of any profile, at any pitch, and for any rainfall intensity to achieve effective roof drainage.
- **5.8.1 Maximum Area Above Spreader Calculator:** To calculate the maximum allowable area feeding into spreaders.
- **9.4.4 Maximum Area Above Penetration Calculator:** To calculate the maximum allowable area above roof penetrations.

The rest of this update consisted of fixing minor errors and improvements for clarity.

19.11A Revision Detail - 2020 - December

Category	Clause Number	Clause (As of current publication) (at time of update)	Details
2 - Editing and rearrangement	1	1 Introduction	Update Revisions Message
1 - Minor Errata	1.3	1.3 Standards and Related Documents	Clause renamed.
1 - Minor Errata	4.10.1	4.9.1 Dissimilar Metals	Formatting fix.
1 - Minor Errata	4.10.3	4.9.4 Compatibility Table	Removed reference to Butly Rubber into its own clause 4.9.3 Compatibility with Non-Metallic Substances .
2 - Editing and rearrangement	4.12	4.11 Inert Catchment	Inserted photo "Localised Damage due to Inert Catchment".
1 - Minor Errata	5.2.4.6	5.5.6 Asymmetrical Valleys	Punctuation fix.
2 - Editing and rearrangement	5.2.5	7.1.3 Roof Drainage Capacity	Clause renamed to more accurately reflect its content.
4 - Clause Inserted	5.4.3	5.8.1 Maximum Area Above Spreader Calculator	New online tool for calculating maximum drainage areas for spreaders.
1 - Minor Errata	5.5	5.4.2 Gutter Capacity Design	Grammar fix.
2 - Editing and rearrangement	5.6.3	5.3.2 Rainfall Intensity	Rainfall intensity maps have been added to this clause. Links to rainfall maps have been included in the calculators.
1 - Minor Errata	5.6.3.2	5.3.2.3 Allowance for Short-Term Intensities	Updated short-term intensity multiplication factors.

Category	Clause Number (at time of update)	Clause (As of current publication)	Details
2 - Editing and rearrangement	5.7	5.4.7 Gutter Capacity Calculator	Renamed the clause. Other capacity calculators have been moved closer to the relevant information dealing with each topic.
0 - Clause Removed	5.7.1	North Island 50-year ARI, 10-minute Rainfall Intensity Map	Map moved to 5.3.2 Rainfall Intensity .
0 - Clause Removed	5.7.2	South Island 50-year ARI, 10-minute Rainfall Intensity Map	Map moved to 5.3.2 Rainfall Intensity .
3 - Substantial change to recommendation	7.1.2	7.1.2 Runoff	Clause completely revised.
4 - Clause Inserted	7.1.3	7.1.4 Maximum Run Calculator	New online tool to calculate maximum run for drainage of different roofing profiles.
2 - Editing and rearrangement	8.4.4.4	8.5.4.4 Eaves Flashing	Inserted a paragraph recommending eaves flashings in Marine Environments.
1 - Minor Errata	9.4.2	9.4.2 Curb Design	Introductory copy added.
4 - Clause Inserted	9.4.4	9.4.4 Maximum Area Above Penetration Calculator	New online tool for calculating the maximum area above a penetration.
1 - Minor Errata	17.2.3.1	17.2.3.1 Site Testing	Updated the graph.
4 - Clause Inserted		4.9.3 Compatibility with Non-Metallic Substances	A new clause, previously part of "4.10.3 Compatibility Table". Information was split since this is not part of the table or online tool.
4 - Clause Inserted		5.5.7 Valley Capacity Calculator	New clause created for Valley Capacity Calculator. The calculator was previously part of Capacity Calculators.
4 - Clause Inserted		5.7.3 Downpipe Capacity Calculator	New clause for Downpipe Capacity Calculators.
4 - Clause Inserted		19.11 2020 – December	New clause showing updates effective on 1 December 2020.

19.12 2020 – September

The following updates to the NZ Metal Roof and Wall Cladding Code Practice (COP) were published on 1 September 2020.

Summary of Changes in this update:

- New standard added for [17.4 MRM Pre-Painted Coil Standard – Performance Requirements](#).
- Additional information on salt contamination added to [4.2 Metal Corrosion](#).
- Revised [2.1 Definitions](#) of Gutter and Valley.
- The rest of this update consisted of fixing minor errors and improvements for clarity.

19.12A Revision Detail - 2020 - September

Category	Clause Number (at time of update)	Clause (As of current publication)	Details
2 - Editing and 1 rearrangement		1 Introduction	Update Revisions Message
2 - Editing and 2.1 rearrangement		2.1 Definitions	Revised definitions of Gutter and Valley.
2 - Editing and 4.2 rearrangement		4.2 Metal Corrosion	Added paragraph about salt contamination.
1 - Minor Errata	5.7	5.4.7 Gutter Capacity Calculator	Clarity improvement. Inserted the Comment: "Please read with Roof Drainage Design "
1 - Minor Errata	9.3	9.3 Penetration Durability and Compatibility	Renamed clause to be more reflective of its content.
1 - Minor Errata	12.4.1	12.5.1 Touch-Up	Changed punctuation in heading for consistency.
2 - Editing and 15.2 rearrangement		15.2 Mounting Air Conditioning, Aerials, and Solar Units	Clause has been renamed and new copy included.
2 - Editing and 17 rearrangement		17 Testing and MRM Standards	Added introduction.
1 - Minor Errata	18.6	18.6 Velocities	Removed extra heading.
1 - Minor Errata	18.7	18.7 Cricket Penetration Patterns	Fixed headings.
4 - Clause Inserted		17.4 MRM Pre-Painted Coil Standard – Performance Requirements	New clause.
4 - Clause Inserted		17.4.1 Part1: ASNZS/2728:2013	New clause.

Category	Clause Number (at time of update)	Clause (As of current publication)	Details
4 - Clause Inserted		17.4.2 Part 2: Additional Criteria	New clause.
4 - Clause Inserted		17.4.3 Commentary	New clause.
4 - Clause Inserted		17.4.4 Appendices of AS/NZS 2728:2013 included as Normative in the MRM Standard	New clause.
4 - Clause Inserted		17.4.5 Appendices of AS/NZS2728:2013 considered Informative in the MRM Standard:	New clause.
4 - Clause Inserted		17.4.6 Copyright Acknowledgement	New clause.

19.13 2020 – June

The following updates to the NZ Metal Roof and Wall Cladding Code Practice (COP), are effective 1 June 2020.

New clauses:

- In this update, we included new clauses concerning [17.2 MRM Fastener Performance Requirements and Testing](#) and [17.3 MRM Soft Edge Standard](#).
- We updated [3.9 Fastener Requirements and Overhangs](#) to include [3.11.2 Aluminium Cladding Wind Load Span Graphs](#).
- We added a new table [5.3.3 Minimum Freeboard Values](#) to [5.3 Roof Drainage Design](#) and implemented interface refinements to [5.4.7 Gutter Capacity Calculator](#).

The rest of this update consists of minor improvements, such as tidying up drawings and edits for clarity and grammar.

19.13A Revision Detail - 2020 - June

Category	Clause Number	Clause (As of current publication) (at time of update)	Details
2 - Editing and rearrangement	1	1 Introduction	Update Revisions Message
2 - Editing and rearrangement	3.16.4	3.9.4 Fastener Patterns	Fastener pattern illustrations updated for clarity - no change to intent.
2 - Editing and rearrangement	3.16.5	3.11.1 Steel Cladding Wind Load Span Graphs	Clause renamed.
2 - Editing and rearrangement	3.16.5.1	3.11.1.1 Corrugated Steel – 0.40	Clause renamed and Fastener pattern illustrations updated for clarity - no change to intent.
2 - Editing and rearrangement	3.16.5.3	3.11.1.2 Corrugated Steel – 0.55	Clause renamed and Fastener pattern illustrations updated for clarity - no change to intent.
2 - Editing and rearrangement	3.16.5.2	3.11.1.3 Trapezoidal Five Rib Steel – 0.40	Clause renamed and Fastener pattern illustrations updated for clarity - no change to intent.
2 - Editing and rearrangement	3.16.5.4	3.11.1.4 Trapezoidal Five Rib Steel – 0.55	Clause renamed and Fastener pattern illustrations updated for clarity - no change to intent.
2 - Editing and rearrangement	3.16.5.5	3.11.1.5 Trapezoidal Six Rib Steel – 0.40	Clause renamed and Fastener pattern illustrations updated for clarity - no change to intent.
2 - Editing and rearrangement	3.16.5.6	3.11.1.6 Trapezoidal Six Rib Steel – 0.55	Clause renamed and Fastener pattern illustrations updated for clarity - no change to intent.

Category	Clause Number (at time of update)	Clause (As of current publication)	Details
4 - Clause Inserted		3.11.2 Aluminium Cladding Wind Load Span Graphs	New clause.
4 - Clause Inserted		3.11.2.1 Corrugated Aluminium – 0.70	New Clause for Aluminium Cladding Wind Load Span Graphs.
4 - Clause Inserted		3.11.2.2 Corrugated Aluminium – 0.90	New Clause for Aluminium Cladding Wind Load Span Graphs.
4 - Clause Inserted		3.11.2.3 Trapezoidal Five Rib Aluminium – 0.70	New Clause for Aluminium Cladding Wind Load Span Graphs.
4 - Clause Inserted		3.11.2.4 Trapezoidal Five Rib Aluminium – 0.90	New Clause for Aluminium Cladding Wind Load Span Graphs.
3 - Substantial change to recommendation	5.6.3	5.3.2 Rainfall Intensity	Clause had been completely revised, with updated Rainfall Intensity Maps at the end of the main Clause, Roof Drainage.
1 - Minor Errata	5.6.3.1	5.3.2.2 Duration	Replaced comparison chart with a simplified one.
2 - Editing and rearrangement	8.3	8.4 Flashing Cover	Added minimum flashing cover values for change of pitch junctions.
4 - Clause Inserted		17 Testing and MRM Standards	New clause.
2 - Editing and rearrangement	17	17.1 Metal Cladding Testing	Clause renamed.
1 - Minor Errata	17.5.1	17.1.5.1 Allowance for Variation	Fixed "overall" to "over all"
4 - Clause Inserted		17.2 MRM Fastener Performance Requirements and Testing	New clause.
4 - Clause Inserted		17.2.1 Requirements for Fastener Testing	New clause.
4 - Clause Inserted		17.2.2 Test Panel Requirements	New Clause.
4 - Clause Inserted		17.2.2.1 Test Location	New Clause.
4 - Clause Inserted		17.2.2.2 Site Orientation	New Clause.
4 - Clause Inserted		17.2.2.3 Preparation of Test Panel	New Clause.
4 - Clause Inserted		17.2.3 Fastener Performance Testing	New Clause.
4 - Clause Inserted		17.2.3.1 Site Testing	New clause.

Category	Clause Number	Clause (As of current publication) (at time of update)	Details
4 - Clause Inserted		17.2.3.2 Field Performance Validation	New clause.
4 - Clause Inserted		17.2.3.3 Accelerated Testing	New clause.
4 - Clause Inserted		17.2.3.4 Fastener Shanks	New clause.
4 - Clause Inserted		17.2.3.5 Sealing Washer Conductivity	New clause.
4 - Clause Inserted		17.2.4 Appearance	New clause.
4 - Clause Inserted		17.2.5 Weatherproofing	New Clause.
4 - Clause Inserted		17.2.6 Fastener Performance Test Report	New clause.
4 - Clause Inserted		17.3 MRM Soft Edge Standard	New clause.
4 - Clause Inserted		17.3.1 Soft Edge Product Technical Statement Requirements	New clause.
4 - Clause Inserted		19.13 2020 – June	New clause. Revision detail.
0 - Clause Removed	5.5	Gutters	The clause had been removed. Gutters are now discussed in more detail in a separate clause for each type, under the main clause Types of Gutter.

19.14 2020 – March

The following updates to the NZ Metal Roof and Wall Cladding Code Practice (COP), are effective 1 March 2020.

This update contains only minor revisions, mostly concerning grammar and punctuation fixes.

Editing and rearrangement for clarity

- Corrected "upstand angles" of valleys to 90°, removed "Upstand Angles" from Internal Valley Angle Table.
- Replaced Comparison of 10-Minute Published Intensity with 1-Minute and 2-Minute Intensities-chart with a simplified chart only showing comparison for 10-year and 50-year ARI.

19.14A Revision Detail - 2020 - March

Category	Clause Number (at time of update)	Clause (As of current publication)	Details
2 - Editing and 1 rearrangement		1 Introduction	Update Revisions Message
1 - Minor Errata	5.2	5.4 Gutters	Easier to read layout options.
1 - Minor Errata	5.2.1	5.4.1 External Gutters (Spouting)	Grammar fix.
1 - Minor Errata	5.2.3	5.4.5 Internal Gutters	Grammar fix.
2 - Editing and 2 rearrangement	5.2.4.2	5.5.2 Valley Design	Removed references to "Upstand Angle B" and replaced drawing "Common Valley Shapes"
1 - Minor Errata	5.2.4.6	5.5.6 Asymmetrical Valleys	Punctuation fix.
1 - Minor Errata	5.3.1	5.6.1 Rainwater Heads	Punctuation fix.
1 - Minor Errata	5.3.2	5.6.2 Sumps	Typo fix.
1 - Minor Errata	5.4	5.7 Outlets and Downpipes	Punctuation fix.
1 - Minor Errata	5.5.3	14.18.9 Gutter Installation	Minor Typo Fix.
1 - Minor Errata	5.6.2	5.4.2.1 Gutter Fall	Typo fix.
1 - Minor Errata	5.6.3.1	5.3.2.2 Duration	Replaced comparison chart with a simplified one.
1 - Minor Errata	8.9.1	8.10.1 Flashing Expansion	Grammar fix.

19.15 2019 – December

The following updates to the NZ Metal Roof and Wall Cladding Code Practice (COP), are effective 1 December 2019.

Major Revisions

- For this update, the COP section **5 Roof Drainage** and all its sub-clauses have been substantially revised. The updates focussed heavily on creating new online tools for calculating *Roof Drainage*, *Gutter Capacity*, *Downpipe Capacity* and *Valley Capacity*, which are located in **5.4.7 Gutter Capacity Calculator**.

Summary of other changes in this update

- All the content in **5 Roof Drainage** has been updated to provide clarity and brevity, and detail drawings are updated.
- The previous methods of capacity calculations, using two distinct methods based on standard sizes, have been removed and replaced by online calculator in **5.4.7 Gutter Capacity Calculator**.
- New clauses have been added for **17.1.3.2 Point Load Testing** and **17.1.1.2 Point Load Testing Standard** under **17.1 Metal Cladding Testing**.
- The Glossary has been updated with **2.1A Definitions** for Swiss Gable, Finial, and Profiled Washer; and some minor edits to refine definitions and grammar fixes.

19.15A Revision Detail - 2019 - December

Category	Clause Number	Clause (As of current publication)	Details
2 - Editing and rearrangement	1	1 Introduction	Update Revisions Message
2 - Editing and rearrangement	2.1	2.1 Definitions	Revised definition of "Load Spreading Washer", added a new item "Profiled Washer", added definition for "Finial", minor grammatical fixes.
2 - Editing and rearrangement	5	5 Roof Drainage	The entire Roof Drainage-clause had been revised.
1 - Minor Errata	5.1	5.1 NZBC: Clause E1 – Surface Water	Formatting
4 - Clause Inserted		5.4 Gutters	New clause.
4 - Clause Inserted		5.4.1 External Gutters (Spouting)	New clause.
2 - Editing and rearrangement	5.5.5	5.4.4 Concealed Fascia Gutters	This clause had been completely revised and renamed.
2 - Editing and rearrangement	5.5.4	5.4.5 Internal Gutters	Clause completely revised.

Category	Clause Number (at time of update)	Clause (As of current publication)	Details
4 - Clause Inserted		5.4.5.1 Internal Gutter Design Features	New clause.
2 - Editing and rearrangement	5.6	5.5 Valleys	Valleys had been completely revised and divided into smaller, more specific, sections.
4 - Clause Inserted		5.5.1 Valley Fixing	New clause.
4 - Clause Inserted		5.5.2 Valley Design	New clause.
4 - Clause Inserted		5.4.3 Internal Corners	New clause.
2 - Editing and rearrangement	5.6.2	5.5.3 Bifurcated Valleys	The clause had been revised. Valleys are now discussed in smaller, more specific, clauses.
4 - Clause Inserted		5.5.5 Changing Angles in Valleys	New clause.
4 - Clause Inserted		5.5.6 Asymmetrical Valleys	New clause.
4 - Clause Inserted		7.1.3 Roof Drainage Capacity	New clause.
3 - Substantial change to recommendation	5.5.7	5.4.6 Secret Gutters	Clause revised, for brevity and clarity.
4 - Clause Inserted		5.6 Rainwater Heads, Sumps, and Overflows	New clause.
2 - Editing and rearrangement	5.8.1	5.6.1 Rainwater Heads	Clause revised, now providing more information.
2 - Editing and rearrangement	5.8	5.6.2 Sumps	This clause has been revised.
2 - Editing and rearrangement	5.8.2	5.6.3 Overflows	Clause renamed, Outlets are now discussed under Outlets and Downpipes.
4 - Clause Inserted		5.7 Outlets and Downpipes	New clause.
4 - Clause Inserted		5.7.1 Placement of Downpipes	New clause.
4 - Clause Inserted		5.7.2 Capacity Table for Common Size Downpipes	New clause.
2 - Editing and rearrangement	5.5.1	5.4.2 Gutter Capacity Design	Clause has been revised and edited.
4 - Clause Inserted		5.4.2.2 Maximum Gutter Length	New clause.

Category	Clause Number (at time of update)	Clause (As of current publication)	Details
2 - Editing and rearrangement	5.5.2	5.4.2.3 Gutter Support Systems	Clause revised.
4 - Clause Inserted		14.18.9 Gutter Installation	New clause.
2 - Editing and rearrangement	5.2	5.3 Roof Drainage Design	Clause had been completely revised.
2 - Editing and rearrangement	5.3.1	5.3.1 Catchment Area	Caluse has been completely revised. All calculations are now under a new clause Capacity Calculations.
2 - Editing and rearrangement	5.5.8	5.4.2.1 Gutter Fall	Clause revised and renamed.
3 - Substantial change to recommendation	5.3	5.3.2 Rainfall Intensity	Clause had been completely revised, with updated Rainfall Intensity Maps at the end of the main Clause, Roof Drainage.
4 - Clause Inserted		5.3.2.3 Allowance for Short-Term Intensities	New clause.
4 - Clause Inserted		5.3.2.2 Duration	New clause
2 - Editing and rearrangement	5.3.2	5.4.7 Gutter Capacity Calculator	The old clause, Capacity Calculations, replaced by a new clause of the same name but including new online tools.
4 - Clause Inserted		5.7.1 North Island 50-year ARI, 10-minute Rainfall Intensity Map	New clause.
4 - Clause Inserted		5.7.2 South Island 50-year ARI, 10-minute Rainfall Intensity Map	New clause.
4 - Clause Inserted	8.3	8.4 Flashing Cover	Adjusted spacing in Table 8.3A
2 - Editing and rearrangement	8.4.4.3	8.5.4.3 Step Apron	Removed reference to "Fortress Fasteners" in drawing A: Step Apron Details.
4 - Clause Inserted	8.4.4.4	8.5.4.4 Eaves Flashing	Drawing 8.4.4.4A renamed to Gutter Flashing.
2 - Editing and rearrangement	12.2	12.2 Purlin Creasing	Inserted photograph.
4 - Clause Inserted	17.1.2	17.1.1.2 Point Load Testing Standard	New Clause.
4 - Clause Inserted	17.3.2	17.1.3.2 Point Load Testing	New clause.
1 - Minor Errata	18.8	18.8 Sheet Metal Work For Roofing Contractors.	Clause revised for gender neutrality. No significant changes.

Category	Clause Number	Clause (As of current publication) (at time of update)	Details
4 - Clause Inserted		19.15 2019 – December	Summary of Changes – December 2019
0 - Clause Removed	5.3.2.1	Method 1: Gutter and Downpipe Capacity Determined by Graph	These methods have been replaced by online capacity calculating tools.
0 - Clause Removed	5.3.2.3	Method 2: Gutter and Downpipe Capacity Determined by Calculations	These methods have been replaced by online capacity calculating tools.
0 - Clause Removed	5.3.3	Roof Cladding Capacity	These methods have been replaced by online capacity calculating tools.
0 - Clause Removed	5.4	Snow	Clause removed, Snow and hail are comprehensively discussed in Snow Loads.
0 - Clause Removed	5.4.1	Hail	Clause removed. Leaf guards and maintenance are discussed under Gutter Maintenance.
0 - Clause Removed	5.5	Gutters	The clause had been removed. Gutters are now discussed in more detail in a separate clause for each type, under the main clause Types of Gutter.
0 - Clause Removed	5.5.3	Eaves Gutters	Clause deleted. Now discussed under External Gutters.
0 - Clause Removed	5.6.1	Valley Catchment	This clause had been replaced with the newly developed online tool in Valley Capacity Calculations.
0 - Clause Removed	5.7	Downpipes	Information previously contained in this clause is now discussed in Outlets and Downpipes.
Out-of-band updates 16/12/2019			
2 - Editing and rearrangement	5.4.2A	5.7.2 Capacity Table for Common Size Downpipes	Removed obsolete column for Roof Area Drained as the online calculator replaces this.
2 - Editing and rearrangement	5.7	5.4.7 Gutter Capacity Calculator	Added link to Common Sized Downpipes.

19.16 2019 – August

The following updates to the NZ Metal Roof and Wall Cladding Code Practice (COP), are effective 1 August 2019.

Major Revisions

1. The main clause **17.1 Metal Cladding Testing** was substantially revised to give more practical guidance for testing in accordance with the NZ MRM Code of Practice.
2. The main clause **13 Safety** has been substantially revised and updated to closer reflect the Health and Safety at Work Act 2015, referencing the documents Worksafe: Working on Roofs and **Worksafe: Working at Height in New Zealand**.
3. The sub-clause **14.20A Fixing Aluminium** has been substantially revised to better reflect good trade practice and manufacturers' recommendations.

Summary of other changes in this update

- **9.4 Penetration Design** has been reorganised so sheetmetal back curb designs are now shown in different clauses for corrugated and trapezoidal profiles.
- **9.4 Penetration Design** now includes an easy-use-use guide for penetration flashing design.
- Previously missing design details have been added for **9.4.2.6F Cricket Under-Soaker: Trapezoidal** and **9.4.2.6D Arrowhead Under-Soaker: Trapezoidal**.
- Trough Section and Standing Seam have been added to **3.4 Profiles** descriptions in Structure.

19.16A Revision Detail - 2019 - August

Category	Clause Number	Clause (As of current publication) (at time of update)	Details
4 - Clause Inserted		19.16 2019 – August	Summary of Changes – August 2019
1 - Minor Errata	10.5	10.5 Building Airtightness	Minor errata: changed 36.2 to 3602
0 - Clause Removed	9.4	Penetration Positioning	Clause is now included in Penetration Design.
2 - Editing and rearrangement	9.5	9.4 Penetration Design	Revised clause. Penetration Positioning is now included in this clause.
1 - Minor Errata	14.8	14.9 Setting Out	Typo correction
4 - Clause Inserted	9.6	9.5 Boot Flashings	Changed the word profile to profiles for consistency with the rest of the document.
4 - Clause Inserted		9.4.2.4 Sheetmetal Penetration-Flashings Reference	New clause to compare penetration flashing options.
2 - Editing and rearrangement	9.5.3	9.4.1.2 Under-Soaker Back Flashings	Clause renamed for consistency.

Category	Clause Number (at time of update)	Clause (As of current publication)	Details
1 - Minor Errata	9.5.4.3	9.4.2.3 Cricket Back Curbs	Changed kerb to curb for consistency.
1 - Minor Errata	8.3	8.4 Flashing Cover	Corrected a misprint, removed <20mm from aprons, category B.
1 - Minor Errata	14.13.4	14.14.4 Fastener Allowance for Expansion	Fixed 8 mm for style consistency.
2 - Editing and rearrangement	14.12.1	14.13.1 Nails	Photo of Nail Pull-Out inserted.
4 - Clause Inserted		14.20.1 Painted Aluminium	Newly created clause dealing with Painted Aluminum products
4 - Clause Inserted		14.20.2 Recommendations for Fixing Aluminium	Newly created clause setting out COP recommendations for fixing aluminium cladding.
0 - Clause Removed	13	Site Practice	Clause removed. Topics previously discussed in Site Practice is now dealt with in more detail in various clauses under Installation.
3 - Substantial change to recommendation	13.1	13 Safety	Safety has been updated in accordance with the Health and Safety at Work Act 2015 (HSWA 2015).
3 - Substantial change to recommendation	13.1.1	13.2 Responsibilities	Clause updated in accordance with the Health and Safety at Work Act (HSWA) 2015.
3 - Substantial change to recommendation	13.1.7	13.4.1 Scaffolding	Clause has been substantially revised in accordance with Worksafe: Working at height in New Zealand.
3 - Substantial change to recommendation	13.1.10	13.4.3 Safety Mesh	This clause has been substantially revised in accordance with Worksafe: Working at Height in New Zealand.
4 - Clause Inserted		13.4.6 Safety Harness	New clause.
4 - Clause Inserted		13.4.7 Soft Landing Systems	New clause.
2 - Editing and rearrangement	14.21	14.22 Tools Of The Trade	Picture added: Turn Up and Turn Down Tools.
2 - Editing and rearrangement	9.5.2	9.4.1.1 Over-Flashed (Watershed) Back Flashings	Clause has been renamed.
0 - Clause Removed	13.1.2	Training	Clause removed. Whole main clause (Safety) has been substantially revised in accordance with HSWA 2015 and Worksafe guidelines.

Category	Clause Number	Clause (As of current publication) (at time of update)	Details
0 - Clause Removed	13.1.5	Limitations Of Fall Arrest And Travel Restraint	Clause removed. Whole main clause (Safety) has been substantially revised in accordance with HSWA 2015 and Worksafe guidelines.
0 - Clause Removed	13.1.4	Residential And Light Commercial Roofing	Clause removed. Whole main clause (Safety) has been substantially revised in accordance with HSWA 2015 and Worksafe guidelines.
0 - Clause Removed	13.1.13	Roof Access During Construction	Clause removed. Whole main clause (Safety) has been substantially revised in accordance with HSWA 2015 and Worksafe guidelines.
0 - Clause Removed	13.1.12	Joining Safety Mesh	Clause removed. Whole main clause (Safety) has been substantially revised in accordance with HSWA 2015 and Worksafe guidelines.
0 - Clause Removed	13.1.11	Steel Fixing	Clause removed. Whole main clause (Safety) has been substantially revised in accordance with HSWA 2015 and Worksafe guidelines.
0 - Clause Removed	13.1.9	Personal Safety	Clause removed. Whole main clause (Safety) has been substantially revised in accordance with HSWA 2015 and Worksafe guidelines.
0 - Clause Removed	13.1.8	Mobile Scaffolds	Clause removed. Whole main clause (Safety) has been substantially revised in accordance with HSWA 2015 and Worksafe guidelines.
0 - Clause Removed	13.1.6	Access	Clause removed. Whole main clause (Safety) has been substantially revised in accordance with HSWA 2015 and Worksafe guidelines.
4 - Clause Inserted		13.4.5 Mechanical Access Plant	New clause.
4 - Clause Inserted		13.4.4 Safety Netting	New clause.
4 - Clause Inserted		13.3.3 Weather Conditions	New clause.
4 - Clause Inserted		13.3.2 Assessment of Existing Roof Cladding	New clause.
4 - Clause Inserted		13.3.1 Safe Access to Roofs	New clause.

Category	Clause Number	Clause (As of current publication) (at time of update)	Details
4 - Clause Inserted		13.3 Working on Roofs	New clause.
4 - Clause Inserted		13.2.4.1 Other People's Responsibilities	New clause.
4 - Clause Inserted		13.2.4 Other People	New clause.
4 - Clause Inserted		13.2.1 PCBU	New clause.
4 - Clause Inserted		13.2.3.1 Workers' Responsibilities	New clause.
4 - Clause Inserted		13.2.3 Workers	New clause.
4 - Clause Inserted		13.2.2.1 Officer Responsibilities	New clause.
4 - Clause Inserted		13.2.2 Officers	New clause.
4 - Clause Inserted		13.2.1.1 PCBU Responsibilities	New clause.
4 - Clause Inserted	9.5.5	9.4.2.5 Sheetmetal Flashings on Corrugated Profiles	This clause has been revised and renamed to specifically show sheetmetal flashings on corrugated profiles.
4 - Clause Inserted		3.15.4 Standing Seam	New clause.
4 - Clause Inserted		3.4.4 Secret-fixed Profiles	New clause.
2 - Editing and rearrangement	14.3.2	14.3.2 Wet Storage Damage	Removed reference to "Fretting".
2 - Editing and rearrangement	2.1	2.1 Definitions	Updated Glossary item: "Fretting"
2 - Editing and rearrangement	4.12	4.11 Inert Catchment	Inserted photo "Localised Damage due to Inert Catchment".
1 - Minor Errata	14.4	14.4 Site Safety	Fixed link: Safety
1 - Minor Errata	14.5	14.5 Handling	Minor grammatical fix.
1 - Minor Errata	14.7.1	14.7.1 Storing Product with Strippable Film	Grammar fix.
1 - Minor Errata	14.7.2	14.7.2 Using Strippable Film	Grammar fix.
1 - Minor Errata	14.1	14.11 Overhang	Drawing tidy up.
4 - Clause Inserted		17.1 Metal Cladding Testing	New Clause, to replace Testing.

Category	Clause Number	Clause (As of current publication) (at time of update)	Details
4 - Clause Inserted		17.1.1 Standards: AS Standards and COP Testing Standard	New clause.
4 - Clause Inserted		17.1.2 Test Requirements	New Clause
4 - Clause Inserted		17.1.2.1 Supporting Structure and Equipment	New Clause
4 - Clause Inserted		17.1.2.2 Test Set-up	New clause.
4 - Clause Inserted		17.1.2.2.1 Number of Specimens	New clause.
4 - Clause Inserted		17.1.2.2.2 Width of Specimen	New clause.
4 - Clause Inserted		17.1.2.2.3 Number of Spans	New clause.
4 - Clause Inserted		17.1.3 Testing Procedure	New clause.
4 - Clause Inserted		17.1.3.1 UDL Testing	New clause.
4 - Clause Inserted		17.1.5 Publishing Results	New clause.
4 - Clause Inserted		17.1.5.1 Allowance for Variation	New clause.
0 - Clause Removed	17	Testing	The entire clause Testing has been substantially revised and published as Structural Testing to give better guidance on testing according to the Code of Practice Standards.
0 - Clause Removed	17.2	Background to Scope	The entire clause Testing has been substantially revised and published as Structural Testing to give better guidance on testing according to the Code of Practice Standards.
0 - Clause Removed	17.1	Scope	The entire clause Testing has been substantially revised and published as Structural Testing to give better guidance on testing according to the Code of Practice Standards.

Category	Clause Number	Clause (As of current publication) (at time of update)	Details
0 - Clause Removed	17.3	General Methods Of Testing Sheet Roof And Wall Cladding	The entire clause Testing has been substantially revised and published as Structural Testing to give better guidance on testing according to the Code of Practice Standards.
0 - Clause Removed	17.4	Commentary On 16.3	The entire clause Testing has been substantially revised and published as Structural Testing to give better guidance on testing according to the Code of Practice Standards.
0 - Clause Removed	17.5	Determining Wind load Span Graphs	The entire clause Testing has been substantially revised and published as Structural Testing to give better guidance on testing according to the Code of Practice Standards.
0 - Clause Removed	17.6	Specific Methods Of Testing Sheet Roof And Wall Cladding	The entire clause Testing has been substantially revised and published as Structural Testing to give better guidance on testing according to the Code of Practice Standards.
0 - Clause Removed	17.7	Wind and Point Load Testing	The entire clause Testing has been substantially revised and published as Structural Testing to give better guidance on testing according to the Code of Practice Standards.
0 - Clause Removed	17.8	Method: Resistance To Wind Pressures For New Zealand	The entire clause Testing has been substantially revised and published as Structural Testing to give better guidance on testing according to the Code of Practice Standards.
0 - Clause Removed	17.9	Background to wind load testing	The entire clause Testing has been substantially revised and published as Structural Testing to give better guidance on testing according to the Code of Practice Standards.
4 - Clause Inserted		17.1.5.3 Interpreting Point Load Results	New clause.
4 - Clause Inserted		17.1.3.2 Point Load Testing	New clause.
4 - Clause Inserted		17.1.1.1 UDL Load Testing Standard	New clause.

Category	Clause Number	Clause (As of current publication) (at time of update)	Details
4 - Clause Inserted		9.4.2.7 Cricket Over-Flashing More Than 1 m Wide	New clause.
4 - Clause Inserted		9.4.3 Dormer Details	New clause.
4 - Clause Inserted		17.1.1.2 Point Load Testing Standard	New Clause.
1 - Minor Errata	14.2.2	14.2.2 Ordering	Punctuation fix.
3 - Substantial change to recommendation	13.1.3.1	13.4.2 Roof Edge Protection	Clause has been substantially revised in accordance with Worksafe: Working at Height in New Zealand.
3 - Substantial change to recommendation	13.1.3	13.4 Working At Height	Clause has been substantially revised in accordance with the HSWA 2015.
4 - Clause Inserted		9.4.2.6 Sheetmetal Flashings on Trapezoidal Profiles	New clause, specifically showing penetration flashings on trapezoidal profiles.
3 - Substantial change to recommendation	14.19	14.20 Fixing Aluminium Sheeting	Section comprehensively revised to better reflect good trade practice and Manufacturer's recommendations.
2 - Editing and rearrangement	3.15	3.4 Profiles	Inserted new Drawing: Profile Types
2 - Editing and rearrangement	3.15.2	3.4.2 Trapezoidal Profile	Removed drawing in favour of a more descriptive drawing: Profile Types.
4 - Clause Inserted	9.5.1	9.4.1 Sheetmetal Penetration Back Flashings	Table removed.
4 - Clause Inserted		17.1.4 Test Report	New clause.
4 - Clause Inserted		17.1.5.2 Interpreting UDL Load Results	New clause.
4 - Clause Inserted		17.1.3.2 Point Load Testing	New clause.

19.17 2019 – May

The following updates to the NZ Metal Roof and Wall Cladding Code Practice (COP), are effective 1 May 2019.

Important updates:

The main clause Roof Ventilation was renamed **10 Internal Moisture** and completely revised and updated. The revised clause recommends designing and installing roof cladding to allow natural ventilation in residential buildings and requires design to enable ventilation in skillion, sarked, and low-pitched residential roofs.

Summary of other changes in this update

- The main clause **14 Installation** was revised and updated for clarity.
- Some clauses from **13 Site Practice** were moved to be included in the more relevant clause Installation. Site Practice now contains mainly **13 Safety**.
- Some clauses in **17 Testing** were renamed and renumbered to fix broken links and reflect content more accurately. A major revision of **17 Testing** is underway.
- Other changes are Category 1 updates, which fixed minor errata such as grammar, spelling, and layout.

19.17A Revision Detail - 2019 - May

Category	Clause Number (at time of update)	Clause (As of current publication)	Details
2 - Editing and rearrangement	2.1	2.1 Definitions	Updated Glossary to include the terms: "Square Stopping".
2 - Editing and rearrangement	3.5.4	3.5.1.2 Load Distribution	Minor edit to drawing (3.5.1.2C Deflection and the Square of Depth)
1 - Minor Errata	3.12.1.1	3.8.2 Steel Purlins	Edited for Consistency – changed 1.1 mm to 1 mm.
1 - Minor Errata	4.1	4.1 NZBC Clause B2 (Extract)	Revised for clarity.
1 - Minor Errata	4.1.1	4.1.1 B2 Objective	Reformatting
1 - Minor Errata	4.1.2	4.1.2 B2 Functional Requirements	Reformatting
1 - Minor Errata	4.1.3	4.1.3 Performance Requirements	Reformatting
2 - Editing and rearrangement	4.11.6	4.10.6 Capillary Action	Changed minimum cover in 4.10.6B Roofing Sheet End Lap to closer reflect MRM recommendations and renamed the drawing.

Category	Clause Number (at time of update)	Clause (As of current publication)	Details
1 - Minor Errata	5.3.2.3	5.3.2.3 Method 2: Gutter and Downpipe Capacity Determined by Calculations	Fixed broken link to E Standard Gutter Capacity and F Standard Down Pipe Capacity , and rewrote link copy for greater clarity.
2 - Editing and rearrangement	8.9.1	8.10.1 Flashing Expansion	First line revised for clarity.
2 - Editing and rearrangement	10	10 Internal Moisture	Clause renamed to <i>Internal Moisture</i> . Clause revised for clarity.
2 - Editing and rearrangement	10.1	10.9 Minimising Ingress of Water Vapour into the Ceiling Cavity	Clause renamed and revised for clarity.
4 - Clause Inserted	10.1.1	10.1.1 E3 Objective	New Clause
4 - Clause Inserted	10.1.2	10.1.2 E3 Functional Requirements	New Clause created
4 - Clause Inserted	10.1.3	10.1.3 E3 Performance Requirements	New clause created.
4 - Clause Inserted	10.2	10.2 Why Manage Internal Moisture	Newly created clause
2 - Editing and rearrangement	10.4	10.3 Special Requirements	Clause revised for clarity and relevance.
0 - Clause Removed	10.4	10.4 The External Environment	Clause removed, information has been revised and moved to other main clauses.
2 - Editing and rearrangement	10.5	10.4 Condensation	Clause completely rewritten.
2 - Editing and rearrangement	10.6	10.5 Building Airtightness	Clause completely rewritten.
0 - Clause Removed	10.6.1	10.6.1 Natural Ventilation	Clause removed. New drawings used in more relevant clauses.
4 - Clause Inserted	10.7	10.6 Insulation	Newly created clause.
4 - Clause Inserted	10.7.1	10.6.1 Insulation Position	Newly created clause
4 - Clause Inserted	10.7.2	10.6.2 Other Insulation	Newly created clause
0 - Clause Removed	10.7.4.1	10.7.4.1 Direction of Lay	Clause delted. Information is now discussed in <i>Horizontal laying</i> and <i>Vertical laying</i> .

Category	Clause Number (at time of update)	Clause (As of current publication)	Details
0 - Clause Removed	10.7.5	10.7.5 Non-Residential Buildings	Clause removed. Information is discussed elsewhere.
2 - Editing and rearrangement	10.8	10.7 Climate	Clause revised for clarity.
0 - Clause Removed	10.8	10.8 Wall Underlay	Clause removed and content discussed in other relevant clauses.
4 - Clause Inserted	10.8.1	10.7.1 Humidity	Relative humidity (RH, given in per cent [%]), is the most widely known method: It gives the content of water vapour in the air relative to the maximum amount of water this parcel of air can hold at its present temperature. Other measures are absolute humidity and water vapour pressure.
2 - Editing and rearrangement	10.9	10.8 Moisture Sources	Renamed and revised clause for clarity. Lead clause for various " <i>Sources of Internal Moisture</i> "
4 - Clause Inserted	10.9.1	10.8.1 Occupant Behaviour	Newly created clause, combining new information with some from revised " <i>Managing Water Vapour at the Source</i> " (renamed <i>Sources of Internal Moisture</i>).
4 - Clause Inserted	10.9.2	10.8.2 Heating	Newly created clause
2 - Editing and rearrangement	10.9.4	10.8.4 Construction Moisture	Clause revised for clarity.
4 - Clause Inserted	10.9.5	10.8.5 Ground Moisture	Newly created clause
2 - Editing and rearrangement	10.11	10.10 Ventilation Pathways	Clause revised for clarity.
4 - Clause Inserted	10.11.1	10.10.1 Methods of Ventilation	Newly created clause
4 - Clause Inserted	10.11.1.1	10.10.1.1 Soffit Vents	Newly created clause.
4 - Clause Inserted	10.11.1.2	10.10.1.2 Fascia Vents	Newly created clause
4 - Clause Inserted	10.11.1.3	10.10.1.3 Ridge Vents	Clause renamed and revised for clarity.
2 - Editing and rearrangement	10.11.1.4	10.10.1.5 Turbine Vents	Clause revised for clarity.

Category	Clause Number (at time of update)	Clause (As of current publication)	Details
4 - Clause Inserted	10.11.2	10.10.2 Battens	Newly Created clause.
2 - Editing and rearrangement	10.12	10.11 Underlay	Clause revised and expanded for clarity.
4 - Clause Inserted	10.12.1	10.11.1 Underlay Requirements	Newly created clause.
2 - Editing and rearrangement	10.12.2	10.11.2 Types Of Underlay	Clause revised for clarity.
4 - Clause Inserted	10.12.3	10.11.3 Underlay Usage	Clause revised for clarity.
2 - Editing and rearrangement	10.12.4	10.11.4 Underlay Durability	Clause revised and expanded.
2 - Editing and rearrangement	10.12.5	10.11.5 Installing Underlay	Clause revised and expanded.
4 - Clause Inserted	10.12.5.1	10.11.5.1 Horizontal Laying	Newly created clause.
4 - Clause Inserted	10.12.5.2	10.11.5.2 Vertical Laying	Newly created clause.
2 - Editing and rearrangement	10.12.5.3	10.11.5.3 Underlay Support	Clause revised.
2 - Editing and rearrangement	10.13	10.12 Additional Information	Clause renamed to <i>Additional Information</i> .
2 - Editing and rearrangement	10.13.1	10.12.1 Cold Roofs	Clause revised for clarity.
2 - Editing and rearrangement	10.13.2	10.12.2 Warm Roofs	Clause revised for clarity.
2 - Editing and rearrangement	10.13.3	10.12.3 Night Sky Radiation	Clause revised for clarity.
2 - Editing and rearrangement	10.13.4	10.12.4 The Mechanics of Condensation	Clause revised and renamed, it is now: <i>The Mechanics of Condensation</i> .
4 - Clause Inserted	10.13.5	10.12.5 Underlay Standards	Newly created clause.
4 - Clause Inserted	10.13.6	10.12.6 Relative Humidity	Newly created clause
4 - Clause Inserted	10.13.7	10.12.7 Absolute Humidity	Newly created clause
4 - Clause Inserted	10.13.8	10.12.8 Water Vapour Pressure	Newly created clause
2 - Editing and rearrangement	13.2	13.1.13 Roof Access During Construction	Clause moved to 13 Safety
0 - Clause Removed	13.4	13.4 Acceptance Of Materials	class="views-field views-field-field-revision-message-revision-id">

Category	Clause Number (at time of update)	Clause (As of current publication)	Details
0 - Clause Removed	13.4.1	13.4.1 Presence Of Moisture Between Sheets	Clause combined with 14.3.2 Wet Storage Damage
0 - Clause Removed	13.4.2	13.4.2 Colour Match	Clause combined with 14.19.5 Colour Matching Paint
0 - Clause Removed	13.4.3	13.4.3 Storage Stain	Clause removed.
0 - Clause Removed	13.5	13.5 Roof Loading	Clause combined with 14.3.1 Unloading
2 - Editing and 14 rearrangement		14 Installation	Clause revised for clarity.
2 - Editing and 14.1 rearrangement		14.1 Pre- Installation	Clause revised for clarity.
2 - Editing and 14.1 rearrangement		14.11 Overhang	Clause revised for clarity
0 - Clause Removed	14.1	14.10 Metal Roof Defects	Clause removed. See 14.19.1 Roof Cladding Damage
0 - Clause Removed	14.1.5	14.1.5 Cutting And Drilling	Clause deleted. Information was spread through other clauses, mainly 14.18.4.4 Repairing Swarf Damage
4 - Clause Inserted	14.2	14.2 Product Selection	Newly Created Clause
2 - Editing and 14.2 rearrangement		14.21 Completion	Clause revised for clarity.
4 - Clause Inserted	14.2.1	14.2.1 Measuring	Newly created clause
0 - Clause Removed	14.2.1	14.2.1 Swarf Removal	clause removed, subject is now discussed in 14.19.4.1 Preventing Swarf Damage .
4 - Clause Inserted	14.2.2	14.2.2 Ordering	Newly created clause.
2 - Editing and 14.2.3 rearrangement		14.2.3 Transportation	Clause revised for clarity and moved to 14 Installation .
4 - Clause Inserted	14.3	14.3 Accepting Delivery	New created clause, combining <i>Acceptance of Materials</i> , previously in <i>Site Practice</i> .
4 - Clause Inserted	14.3.1	14.3.1 Unloading	Newly created clause
0 - Clause Removed	14.3.1	14.3.1 Primary Fasteners	Clause removed. Information is now discussed in various shorter and newly created clauses.
4 - Clause Inserted	14.3.2	14.3.2 Wet Storage Damage	Newly created clause

Category	Clause Number (at time of update)	Clause (As of current publication)	Details
0	14.4	14.4 Secondary Fasteners	class="views-field views-field-field-revision-message-revision-id">
0 - Clause Removed	14.4.2	14.4.2 Monel Rivets	clause removed, information is now discussed in other clauses.
0 - Clause Removed	14.4.3	14.4.3 Aluminium Rivets	Clause removed, information now in 14.13.4 Rivets
0 - Clause Removed	14.4.4	14.4.4 Stainless Steel Rivets	Clause deleted. See 14.13.4 Rivets
0 - Clause Removed	14.4.6	14.4.6 Fastener Frequency	Clause removed. See 14.14.1 Fastener Spacing
2 - Editing and rearrangement	14.5	14.5 Handling	Clause revised for clarity and moved to Installation.
0 - Clause Removed	14.5.2	14.5.2 Pan Fixing	Clause Removed. See 14.13.2 Screws
0 - Clause Removed	14.5.3	14.5.3 Expansion Fixings	Clause removed. See 14.14.4 Fastener Allowance for Expansion
0 - Clause Removed	14.5.4	14.5.4 Lap Stitching	Clause removed. Information absorbed in other clauses.
2 - Editing and rearrangement	14.6	14.6 Walking On Roofs	Clause revised for clarity and moved to 14 Installation .
0 - Clause Removed	14.6	14.6 Installation	Empty heading removed. See 14.14 Fastener Installation .
4 - Clause Inserted	14.6.1	14.6.1 Footwear	Newly created clause
2 - Editing and rearrangement	14.7	14.7 Strippable Films	Clause revised for clarity.
0 - Clause Removed	14.7	14.7 Re-Roofing	Clause removed. Information absorbed in other clauses.
4 - Clause Inserted	14.7.1	14.7.1 Storing Product with Strippable Film	Newly created clause
2 - Editing and rearrangement	14.8	14.9 Setting Out	Clause revised for clarity.
0 - Clause Removed	14.8.2	14.8.2 Side Lap Fixing Between Purlins	Clause removed.
0 - Clause Removed	14.8.6	14.8.6 Purlin Protection	clause removed
0 - Clause Removed	14.8.7	14.8.7 Drainage	Clause removed
0 - Clause Removed	14.8.8	14.8.8 Condensation	Clause removed.
4 - Clause Inserted	14.9	14.10 Marking and Cutting	Newly created clause

Category	Clause Number (at time of update)	Clause (As of current publication)	Details
2 - Editing and rearrangement	14.11	14.12 Sealing and Joining	Clause revised for clarity
4 - Clause Inserted	14.11.1	14.12.1 Sealing End Laps	Newly created clause
2 - Editing and rearrangement	14.12	14.13 Fasteners	Clause revised for clarity.
0	14.12.1	14.13.1 Nails	class="views-field views-field-field-revision-message-revision-id">
2 - Editing and rearrangement	14.12.2	14.13.2 Screws	Clause revised for clarity.
4 - Clause Inserted	14.12.3	14.13.3 Clip Fasteners	Newly created clause.
2 - Editing and rearrangement	14.12.4	14.13.4 Rivets	Clause revised for clarity
2 - Editing and rearrangement	14.13	14.14 Fastener Installation	Clause renamed and revised for clarity.
2 - Editing and rearrangement	14.13.1	14.14.1 Fastener Spacing	Newly created clause
4 - Clause Inserted	14.13.2	14.14.2 Fastener Placement	Newly created clause
4 - Clause Inserted	14.13.3	14.14.3 Fastener Seating	Newly created clause
4 - Clause Inserted	14.13.4	14.14.4 Fastener Allowance for Expansion	Newly created clause
4 - Clause Inserted	14.14	14.15 Modes Of Fastener Failure	Clause revised for clarity
4 - Clause Inserted	14.15	14.16 Stop-ends	Clause revised for clarity.
2 - Editing and rearrangement	14.16	14.17 Turndowns (Drip Forming or Drip Edging)	Clause revised for clarity.
4 - Clause Inserted	14.17	14.18 Soft edging and Flashing	Newly created clause
4 - Clause Inserted	14.18	14.19 Avoiding Problems	Newly created clause heading
2 - Editing and rearrangement	14.18.1	14.19.1 Roof Cladding Damage	Clause revised for clarity and moved to 14 Installation
4 - Clause Inserted	14.18.2	14.19.2 Water Ponding	Newly created clause
4 - Clause Inserted	14.18.3	14.19.3 Correctly Installed Gutters	Newly created clause
0	14.18.4	14.19.4 Swarf Damage	class="views-field views-field-field-revision-message-revision-id">

Category	Clause Number (at time of update)	Clause (As of current publication)	Details
4 - Clause Inserted	14.18.4.1	14.18.4.1 Identifying Swarf Stains	Newly created clause
4 - Clause Inserted	14.18.4.2	14.19.4.1 Preventing Swarf Damage	Newly created clause
4 - Clause Inserted	14.18.4.3	14.18.4.3 Swarf Effect on Performance	Newly created clause.
2 - Editing and rearrangement	14.18.4.4	14.18.4.4 Repairing Swarf Damage	Clause revised for clarity and renamed.
4 - Clause Inserted	14.18.4.5	14.19.4.2 Severe or Extensive Swarf Staining	Newly created clause.
4 - Clause Inserted	14.18.5	14.19.5 Colour Matching Paint	Newly created clause
4 - Clause Inserted	14.18.6	14.19.6 Field Painting	Newly created clause.
4 - Clause Inserted	14.18.7	14.19.7 Sunscreen	Newly created clause.
4 - Clause Inserted	14.18.8	14.18.8 Removing Lichen	Newly created clause.
2 - Editing and rearrangement	14.21	14.22 Tools Of The Trade	Clause revised for clarity.
4 - Clause Inserted	14.21.1	14.22.1 Spacing	Clause removed. See 14.14.1 Fastener Spacing
4 - Clause Inserted	14.22.1	14.23.1 Crest Fixing	Clause removed. See 14.13.2 Screws
4 - Clause Inserted	14.23	14.6.2 Tools	Clause removed. See 14.13.2 Screws
4 - Clause Inserted	14.24	14.8 Translucent Sheeting	Clause removed.
4 - Clause Inserted	14.24.1	14.8.1 Side-Lap Fixing	Clause removed.
4 - Clause Inserted	14.24.2	14.8.3 End Laps	Clause deleted.
4 - Clause Inserted	14.24.3	14.8.4 Midspan Supports	Clause removed
4 - Clause Inserted	14.24.4	14.8.5 Stopends	Clause removed.
4 - Clause Inserted	14.24.5	14.8.9 Pitch	Clause removed.
2 - Editing and rearrangement	17	17 Testing	Edited for clarity.
2 - Editing and rearrangement	17.1	17.1 Scope	Clause revised for clarity

Category	Clause Number (at time of update)	Clause (As of current publication)	Details
1 - Minor Errata	17.1.2	17.1.2 Resistance to point load	Fixed typos – "serviceability" and "strength".
2 - Editing and rearrangement	17.2	17.2 Background to Scope	Heading changed from "Commentary on 16.1" and clause revised for clarity and brevity.
4 - Clause Inserted	17.4	17.4 Commentary On 16.3	Clause removed
2 - Editing and rearrangement	17.5	17.5 Determining Wind load Span Graphs	Minor grammatical edits and clause renamed to "Determining Wind Load Span Graphs" to avoid confusion with 3.11.1 Steel Cladding Wind Load Span Graphs .
1 - Minor Errata	17.6	17.6 Specific Methods Of Testing Sheet Roof And Wall Cladding	Clause moved (renumbered) to follow 17.7 Wind and Point Load Testing .
4 - Clause Inserted	17.7.1	17.7.1 Commentary On Section 15.5	Clause Removed. 17 Testing to undergo major revision.
2 - Editing and rearrangement	17.9	17.9 Background to wind load testing	Renamed "Clause from Commentary on 16.6".

19.18 2019 – February

The following updates to the NZ Metal Roof and Wall Cladding Code Practice (COP), is effective 1 February 2019.

In this update, no recommendations have been altered that would require changes to existing projects in progress.

Summary of Changes in this Update

- Two new clauses were added in **3 Structure** to discuss **3.4.5 Material Grade** and **3.4.6 Material Thickness**.
- Two new, separate, clauses under **4.15 Clearances**, discuss **4.15.1 Ground Clearance** and related **4.15.2 Site Management** in more detail.
- Clauses dealing with **3.12.1 Screw Fasteners** fixing to specific purlin types re-ordered for clarity.
- New drawing to show recommended **9.4A Recommended Penetration Type Positioning**.
- Other updates consist of Category 1 – minor errata corrections to spelling, and grammar and layout.

Category	Clause Number (at time of update)	Clause (As of current publication)	Details
2 - Editing and rearrangement	3.12.1	3.12.1 Screw Fasteners	Clauses dealing with fixing to specific purlin types re-ordered for clarity.
1 - Minor Errata	3.13.1	3.4.1 Corrugate Profile	Minor grammatical editing for clarity.
1 - Minor Errata	3.14.3	3.9.3 Maximum Spans for Corrugate Wall Cladding	Heading says 0.40 mm but Table is .40 and .55. So remove .40 from heading
1 - Minor Errata	4.6.1	4.6.1 Assessment of Marine Environments	Removed full stop from the heading.
2 - Editing and rearrangement	4.8.1	4.8.4 Lichen	Resized photo (4.8.4A Lichen on a Metal Roof) and inserted photo (4.8.4B Permanent Damage from Lichen Growth).
2 - Editing and rearrangement	4.15	4.14 Swarf Staining and Cut Edge Corrosion	Renamed clause. Resized photos and inserted new photo (4.14D Cut Edge Corrosion)
1 - Minor Errata	4.17.3	4.16.3 Aluminium	fixed spelling of "quaters" to quarters
1 - Minor Errata	4.18.1.3	4.17.1.3 Top Coat and Backer	0
1 - Minor Errata	5.3.1	5.3.1 Catchment Area	Removed (Optional Caption) from A Wind-effect on Rain
1 - Minor Errata	6.1.1	6.1.1 E2 Objective	Set format as Block Quote
1 - Minor Errata	6.1.2	6.1.2 E2 Functional Requirement	Format as block Quote.
1 - Minor Errata	6.3	6.3 Related Topics	Changed link "Internal Moisture" to "Roof Ventilation.
2 - Editing and rearrangement	9.5.6	9.4.2.5 Sheetmetal Flashings on Corrugated Profiles	Revised and renamed clause.
1 - Minor Errata	14.5.1	14.23.1 Crest Fixing	Corrected minimum embedment into soft wood from 35mm to 30mm aligning with E2/AS1 and other reference in 3.8.3 Timber Purlins

19.19 2018 – November

The NZ Metal Roof and Wall Cladding Code Practice (COP), has been updated effective 1 November 2018.

In this Update no recommendations have been altered that would require changes to existing projects in progress

Summary of Changes in this Update

- The previous *External Moisture*, *Flashings* and *Penetrations* sections have been updated to closer reflect the requirements of NZBC Clause E2 – External Moisture. All clauses and sub-clauses in these sections have been substantially revised and drawings updated to show details more clearly.
 - **6 External Moisture Overview** gives a general introduction and overview of NZBC Clause E2 – External Moisture.
 - **7 External Moisture Roofing** discusses requirements for roof and wall cladding.
 - **8 External Moisture Flashings** deals with flashings, seals and laps.
 - **9 External Moisture Penetrations** recommends good practice for penetration design and installation.
- Other updates consist of Category 1 – minor errata corrections to spelling, and grammar and layout.

19.19A

Category	Clause Number (at time of update)	Clause (As of current publication)	Details
2 - Editing and rearrangement	4.5.2	4.5.2 Sea Spray	Moved copy dealing with corrosion from "Eaves Flashing" to "Sea Spray".
1 - Minor Errata	4.11.8	4.10.8 Microcracking	Correction to comparative scale of illustrations
0 - Clause Removed	6.1.1	7.1.1 Conduction	
4 - Clause Inserted	6.1.1	6.1.1 E2 Objective	E2 Objective under NZBC Clause E2 (Extract)
4 - Clause Inserted	6.1.2	6.1.2 E2 Functional Requirement	New clause to follow E2 Objective.
4 - Clause Inserted	6.1.3	6.1.3 E2 Performance Requirements	New clause to follow "Functional Requirement".
0 - Clause Removed	6.1	7.1 Heat	Clause removed, see 7.3 Thermal Expansion And Contraction .
4 - Clause Inserted	6.1	6.1 NZBC Clause E2 External Moisture (Extract)	New Clause under External Moisture – General.

Category	Clause Number (at time of update)	Clause (As of current publication)	Details
4 - Clause Inserted	6.2.1	6.2 Compliance	New 2nd level clause to follow "Acceptable Solution NZBC E2/AS1"
0 - Clause Removed	6.2.2.1	7.4.2.1 Profile Strength	Subject now discussed in 7.3 Thermal Expansion And Contraction .
2 - Editing and rearrangement	6.2.2.3	8.10 Flashing Expansion Details	Completely revised clause.
2 - Editing and rearrangement	6.2.2.4	8.10.2 Building Expansion Joints	Clause duplicated.
4 - Clause Inserted	6.2	6.2 Acceptable Solution NZBC E2/AS1	New 2nd level clause to follow "Limits on Applications."
0 - Clause Removed	6.3	8.15 Sealing Washers	
4 - Clause Inserted	6.3	6.3 Related Topics	New 1st level heading under "External Moisture – General"
3 - Substantial change to recommendation	6.5.2	7.1.2 Runoff	Clause completely revised.
0 - Clause Removed	6.5.3	7.2.3 Snow	Clause removed, combined with 5.4 Snow .
0 - Clause Removed	6.5.4	7.2.4 Hail	Clause removed combined with 5.4.1 Hail .
2 - Editing and rearrangement	6	6 External Moisture Overview	Clause completely revised to reflect all four COP clauses dealing with E2 External Moisture.
3 - Substantial change to recommendation	7.1.1	7.1.1 Minimum Roof Cladding Pitch	Clause completely revised.
0 - Clause Removed	7.1	7.1 Radiation	
0 - Clause Removed	7.1	8.1 Purpose	Clause removed, included in 8 External Moisture Flashings .
2 - Editing and rearrangement	7.2.1	8.1.1 Flashing Durability	Completely revised and renamed clause renamed (previously "compatibility").
0 - Clause Removed	7.2	7.2 Convection	
2 - Editing and rearrangement	7.2	7.1 Roof Pitch	Clause completely revised. To be the first sub-clause under External Moisture – Cladding.
2 - Editing and rearrangement	7.2	8.1 Flashing Materials	Completely revised clause

Category	Clause Number (at time of update)	Clause (As of current publication)	Details
4 - Clause Inserted	7.2	7.2 Fastening Roofing	New sub-clause to be inserted at the end of Roof Pitch under External Moisture – Cladding.
3 - Substantial change to recommendation	7.3.1	7.3.1 Temperature Range	Completely Revised and rewritten. To follow "Thermal Expansion and Contraction" under the new level 1 Clause: "Cladding"
4 - Clause Inserted	7.3.1	8.4.4 Flashing Laps	Completely revised and shortened clause.
3 - Substantial change to recommendation	7.3.2	7.3.2 Roof Cladding Expansion Provisions	Completely Revised and Rewritten. To follow "Steel Cladding Temperature Ranges" in "Thermal expansion and Contraction" under new Level 1 Clause: "Cladding".
2 - Editing and rearrangement	7.3	7.3 Thermal Expansion And Contraction	Completely revised and redone. To be moved under new level 1 Clause: External Moisture Cladding.
0 - Clause Removed	7.4.1.1	8.6.1.1 Ridge - Hip Intersections	Clause incorporated into 8.5.1 Ridge And Hip .
2 - Editing and rearrangement	7.4.2	8.5.2 Barge And Verge	Completely revised clause.
0 - Clause Removed	7.4.2.1	8.6.2.1 Internal Barge Flashing	Incorporated into parent clause.
2 - Editing and rearrangement	7.4.2.2	8.5.2.1 Ridge – barge Intersections	Completely revised clause.
2 - Editing and rearrangement	7.4.4	8.5.4 Apron Flashings	Completely revised clause
2 - Editing and rearrangement	7.4.4.1	8.5.4.1 Parapet And Apron Capping Terminations	Completely revised clause.
2 - Editing and rearrangement	7.4.4.3	8.5.4.3 Step Apron	Completely revised clause. Drawings updated.
2 - Editing and rearrangement	7.4.4.4	8.5.4.4 Eaves Flashing	Completely revised and renamed clause. (Previously "Gutter Apron"). Drawing updated.
0 - Clause Removed	7.4.5	8.6.5 Valley Flashings	Clause removed. Valleys are discussed in "Roof Drainage".
2 - Editing and rearrangement	7.4.6	8.5.5 Curved Flashings	Completely revised clause.
2 - Editing and rearrangement	7.4.6.1	8.5.5.1 Lockseamed Flashings	Revised clause. Information added.

Category	Clause Number (at time of update)	Clause (As of current publication)	Details
0 - Clause Removed	7.4.6.2	8.6.6.2 Jennied Flashings	Clause removed – all references to "jennying" has been removed from "Flashings".
4 - Clause Inserted	7.4.6.3	8.5.5.2 Crimped Flashings	New clause under 8.5.5 Curved Flashings .
0 - Clause Removed	7.4.7	8.6.7 Soffit Flashings	Clause removed.
2 - Editing and rearrangement	7.4	7.4 End Laps	Clause completely revised.
2 - Editing and rearrangement	7.4	8.5 Flashing Types	The last line edited.
0 - Clause Removed	7.5.1	8.12.1 Unpainted Metal Cladding	Clause removed.
0 - Clause Removed	7.5.2	8.12.2 Ventilation and Cavities	Clause removed.
0 - Clause Removed	7.5.3	8.12.3 Window and Door Flashings in Metal Cladding	
0 - Clause Removed	7.5.4	8.12.4 Horizontal Metal Cladding	
0 - Clause Removed	7.5.5	8.12.5 General Principles	
0 - Clause Removed	7.5.6	8.12.6 Flush Window Flashings	Clause removed.
0 - Clause Removed	7.5.7	8.12.7 Recessed Window Flashings	Clause removed.
0 - Clause Removed	7.5.8	8.12.8 Butt Window Flashings	Clause removed.
0 - Clause Removed	7.5.9	8.12.9 Flashings For Vertical Cladding	
0 - Clause Removed	7.5.10	8.12.10 Alternative Flashing Designs	
2 - Editing and rearrangement	7.5	8.11 Metal Wall Cladding Flashings	Completely revised and renamed clause.
0 - Clause Removed	7.6	8.13 Flashings For Vertical Cladding	Clause removed.
0 - Clause Removed	7.7	8.14 Flashings For Horizontal Corrugate Cladding	Clause Removed.
2 - Editing and rearrangement	7.8.1	8.6.1 Primary Fasteners	Completely revised and shortened clause.

Category	Clause Number (at time of update)	Clause (As of current publication)	Details
2 - Editing and rearrangement	7.8.2	8.6.2 Secondary Fasteners	Completely revised clause.
0 - Clause Removed	7.8.3	8.7.3 Secret Fixing Clips	Clause deleted.
2 - Editing and rearrangement	7.8.4	8.6.3 Flashing Cleats	
4 - Clause Inserted	7.8.5	8.6.4 Seams	Split the drawing into eight individual drawings, for improved layout.
2 - Editing and rearrangement	7.8	8.6 Fastening Flashings	Clause renamed.
0 - Clause Removed	7.9.1	8.8.1 Properties	Clause removed. Discussed in 8.7 Sealants .
2 - Editing and rearrangement	7.9.2	8.7.1 Methods Of Sealing	Revised clause
2 - Editing and rearrangement	7.9.3	8.7.2 Surface Preparation	Clause shortened.
0 - Clause Removed	7.9.5	8.8.5 Sealed Laps	Clause removed see: A Sealed End Lap .
0 - Clause Removed	7.9.6	8.8.6 Strip Sealants	Clause removed.
0 - Clause Removed	7.9.7	8.8.7 Soldered Joints	Clause Removed.
2 - Editing and rearrangement	7.9	8.7 Sealants	Completely revised clause.
0 - Clause Removed	7.10.1	8.9.1 Vented Fillers	
2 - Editing and rearrangement	7.10.2	8.8.1 Soft Edging	Revised and renamed clause.
2 - Editing and rearrangement	7	8 External Moisture Flashings	Completely revised clause.
4 - Clause Inserted	7	7 External Moisture Roofing	New Level 1 clause.
0 - Clause Removed	8.1	9.1 General	Clause removed. General discussion incorporated in the introduction.
2 - Editing and rearrangement	8.2.1	9.2 Additional Support	Completely revised and renamed clause.
2 - Editing and rearrangement	8.2.2	9.3 Penetration Durability and Compatibility	Completely revised and renamed clause.
0 - Clause Removed	8.2.3	9.5 Corrosion	Incorporated into " 9.3 Penetration Durability and Compatibility ".

Category	Clause Number	Clause (As of current publication) (at time of update)	Details
0 - Clause Removed	8.2.4	9.5.1 Catchment	Clause removed.
0 - Clause Removed	8.2.5	9.5.2 Obstruction	Clause removed.
0 - Clause Removed	8.2.6	9.5.3 Discharge Capacity	Clause removed, see
0 - Clause Removed	8.2.7	9.5.4 Sealing	Clause removed. (Information is repeated in 8 External Moisture Flashings)
0 - Clause Removed	8.2.8	9.5.5 Alternative Materials	Clause removed, see 8.8.1 Soft Edging .
2 - Editing and rearrangement	8.2	8.2 Flashing Design	Completely revised and shortened clause
2 - Editing and rearrangement	8.2	9.1 Penetrations Minimum Pitch	Completely revised and renamed clause.
0 - Clause Removed	8.3.1	9.7.6 Nomenclature	Clause removed. More details added in 9.4 Penetration Design .
0 - Clause Removed	8.3.2	9.7.7 Diverter Or Cricket Designs	Clause removed in favour of more detailed drawings in Penetration Flashing Design.
0 - Clause Removed	8.3.3	9.7.8 Penetration Flashing Installation	Clause removed in favour of more detailed drawings in "Penetration Flashing Design".
0 - Clause Removed	8.3.4	9.7.9 Laps	Clause removed, see 7.4 End Laps .
0 - Clause Removed	8.3.5	9.7.10 Details	Clause removed. See 9.4.2.5 Sheetmetal Flashings on Corrugated Profiles .
0 - Clause Removed	8.3.7	9.7.11 Type A Soaker	
0 - Clause Removed	8.3.8	9.7.12 Type B Watershed	Clause removed. New Details available.
0 - Clause Removed	8.3.9	9.7.13 Type C Tapered	Clause removed. New flashing details provided.
0 - Clause Removed	8.3.10	9.7.14 Type D Tray	Clause removed. New Flashing details provided elsewhere.
2 - Editing and rearrangement	8.3	8.4 Flashing Cover	Completely revised clause. Drawings updated for clarity.
2 - Editing and rearrangement	8.3	9.4 Penetration Design	Revised clause.
2 - Editing and rearrangement	8.4.1	9.5.2.1 Plant Room And Conduit Penetrations	Completely revised clause.
2 - Editing and rearrangement	8.4	8.2.1 Flashing Edges	Completely revised clause. Drawings updated.
2 - Editing and rearrangement	8.5.1	8.5.1 Ridge And Hip	Completely revised clause.

Category	Clause Number (at time of update)	Clause (As of current publication)	Details
2 - Editing and rearrangement	8.5.3	8.5.3 Parapet Cappings	Completely revised clause.
3 - Substantial change to recommendation	8.5.4.2	8.5.4.2 Change Of Pitch	Completely revised clause. Drawings updated.
0 - Clause Removed	8.5	9.9 Dormer Junctions	Clause removed.
4 - Clause Inserted	8.7.3	8.7.3 Sealant Extrusion And Placement	Updated drawing: "Applying Sealant".
4 - Clause Inserted	8.8.2	8.8.2 Notched Edging	New Clause to follow "Soft Edging", under "Profile Closures".
2 - Editing and rearrangement	8.8	8.8 Profile Closures	Completely revised clause.
4 - Clause Inserted	8.9	8.9 Compression Timber	Inserted new clause.
4 - Clause Inserted	8.32	19.19 2018 – November	November Update Message added
2 - Editing and rearrangement	8	9 External Moisture Penetrations	Completely revised and renamed clause.
4 - Clause Inserted	9.3	9.2.1 Penetrations Safety	New sub-clause under "Additional Support".
4 - Clause Inserted	9.5.1	9.4 Penetration Positioning	New Clause.
4 - Clause Inserted	9.5.2	9.4.1 Sheetmetal Penetration Back Flashings	New Clause.
4 - Clause Inserted	9.5.3	9.4.1.1 Over-Flashed (Watershed) Back Flashings	New Clause
4 - Clause Inserted	9.5.4	9.4.1.2 Under-Soaker Back Flashings	New Clause
4 - Clause Inserted	9.5.5	9.4.2 Curb Design	New Level 2 Clause.
4 - Clause Inserted	9.5.5.1	9.4.2.1 Level Back Curbs	New level 3 Clause under 9.4.2 Curb Design .
4 - Clause Inserted	9.5.5.2	9.4.2.2 Arrowhead Back Curbs	New 3rd level clause under 9.4.2 Curb Design .
4 - Clause Inserted	9.5.5.3	9.4.2.3 Cricket Back Curbs	New level 3 Clause under 9.4.2 Curb Design .
2 - Editing and rearrangement	9.5.6	9.4.2.5 Sheetmetal Flashings on Corrugated Profiles	Revised and renamed clause.

Category	Clause Number	Clause (As of current publication) (at time of update)	Details
4 - Clause Inserted	9.6.1	9.5.1 Boot Flashings to an Over Flashing	New Clause
4 - Clause Inserted	9.6.2	9.5.2 Other Applications for Boot Flashings	New Clause
4 - Clause Inserted	9.6.2.2	9.5.2.2 Mechanical Services	New clause
2 - Editing and rearrangement	9.6	9.5 Boot Flashings	Revised and renamed clause.
4 - Clause Inserted	9.7	9.5.3 Flush Penetrations	New clause
2 - Editing and rearrangement	16.7	17.7 Wind and Point Load Testing	

19.20 2018 – October

The NZ Metal Roof and Wall Cladding Code Practice (COP), has been updated effective 1 October 2018.

Summary of Changes in this Update

In this update there are Category 1 - Minor Errata corrections only, for spelling and grammar - no clauses have been substantially revised, nor any recommendations altered.

19.20A Revision Detail - 2018 - October

Category	Clause Number (As of current of update)	Clause (As of current publication)	Details
1 - Minor Errata	1.5.1	1.5.1 Mediation	1. Inserted "a" before settlement. 2. Corrected spelling of "available" in the second paragraph.
1 - Minor Errata	2.1	2.1 Definitions	General tidy up; Fix spelling: Intersection, surface, heights, dewpoint, six-sided, practitioners, seashore, rainwater, coatings, trademark, components, electromagnetic, skylight, sawtooth, embedded, cross-section, violently, stop end, fibreglass, change. Changed: Low Pitched 15° to 10°, and Pitch Roof 15° to 10°. Remove some extra spaces. Removed some commas. Inserted comma. Changed "newton" to "Newton". Reworked Pop Rivet definition. Removed semi-colon. Updated "boot Flashings."
1 - Minor Errata	3.5.6	3.5.6 Section Properties	Moved paragraph: "Symmetrical corrugate or trapezoidal profiles have the advantage of being more easily curved around a radius. Because the ribs are necessarily close together, they have the disadvantage of roof traffic loads having to be spread over two crests or along the purlin line, and they have a lower run-off capacity."
1 - Minor Errata	3.5.8	3.5.1.1 Continuity	Updated Drawing. Arrows were not displaying correctly.
1 - Minor Errata	3.6.1	3.6.1 Point Load	Removed empty paragraph spacing
1 - Minor Errata	4.9.3	4.8.3 Graffiti Removal	Fixed typo "Grafitti"
1 - Minor Errata	4.10.3	4.9.4 Compatibility Table	Inserted "online" in the description of the online interactive tool.

1 - Minor Errata	4.10.6 Capillary Action	Typo – Changed 80 to 8°.
1 - Minor Errata	4.10.8 Microcracking	Replaced drawings a through to e
1 - Minor Errata	5.7 Downpipes	Replaced drawing "Collecting Rainwater"
1 - Minor Errata	6 External Moisture Overview	Fixed typo: "conductionand" to "conduction and"
1 - Minor Errata	10.12.1 Cold Roofs	fixed typo: inserted " is ..."
1 - Minor Errata	10.11 Underlay	1. Added new new photo – 9.5C Condensation on Synthetic Underlay. 2. Typo: corrected spelling of 9.5B "Condesation.." to "Condensation"
1 - Minor Errata	10.7.5 Non- Residential Buildings	Fixed typo: deleted extra "in"
1 - Minor Errata	11 Natural Light	Fixed typos: "thermal", "installation" and "available"
1 - Minor Errata	11.1 Clause G7 NZBC	Fixed typos: "through", "enough"
1 - Minor Errata	11.2 Natural Light Materials	Fixed typos: "a varying mass" and "square"
1 - Minor Errata	11.3 Types Of Roof Lights	Fixed typos: "single" and removed extra space after comma.
1 - Minor Errata	11.5 Weathering And Durability	Fixed typo: "not"
1 - Minor Errata	14.17 Turndowns (Drip Forming or Drip Edging)	changed "downturns" to "Turn-downs" and inserted "drip forming or drip edging" in the heading.
1 - Minor Errata	14.13.2 Screws	1. Fixed typos: "hardwoods", 2. Fixed broken links "Fastener Performance" and "Secret Fixing Clips"
1 - Minor Errata	14.5.3 Expansion Fixings	Fixed link: "favourable conditions for expansion"
1 - Minor Errata	15.1.5 Purlin Spacing	Fixed typo: "subjected", removed comma.
1 - Minor Errata	15.4.2.4 Types Of Joints	Removed unnecessary link: (See drawing 11.2.4)

1 - Minor 16.1.3 Errata	17.1.3 Resistance for wind pressures	Replaced incorrect numbering reference (section 15.7) with correct link (Wind and Point Load Testing)
1 - Minor 16.2 Errata	17.2 Background to Scope	Corrected heading "Commentary on 16.1"
1 - Minor 16.4 Errata	17.4 Commentary On 16.3	Corrected heading: "Commentary On 16.3"
1 - Minor 16.9 Errata	17.9 Background to wind load testing	Corrected heading: "Commentary On Section 16.6"